

You might find this additional information useful...

This article cites 896 articles, 226 of which you can access free at:

<http://physrev.physiology.org/cgi/content/full/84/4/1155#BIBL>

This article has been cited by 23 other HighWire hosted articles, the first 5 are:

Senile hair graying: H₂O₂-mediated oxidative stress affects human hair color by blunting methionine sulfoxide repair

J. M. Wood, H. Decker, H. Hartmann, B. Chavan, H. Rokos, J. D. Spencer, S. Hasse, M. J. Thornton, M. Shalhaf, R. Paus and K. U. Schallreuter
FASEB J, July 1, 2009; 23 (7): 2065-2075.

[Abstract] [Full Text] [PDF]

Endometriosis risk in relation to naevi, freckles and skin sensitivity to sun exposure: the French E3N cohort

M. Kvaskoff, S. Mesrine, F. Clavel-Chapelon and M.-C. Boutron-Ruault
Int. J. Epidemiol., April 7, 2009; 0 (2009): dyp175v1-dyp175.

[Abstract] [Full Text] [PDF]

Regulation of Pigmentation in Human Epidermal Melanocytes by Functional High-Affinity {beta}-Melanocyte-Stimulating Hormone/Melanocortin-4 Receptor Signaling

J. D. Spencer and K. U. Schallreuter
Endocrinology, March 1, 2009; 150 (3): 1250-1258.

[Abstract] [Full Text] [PDF]

Formation of Pmel17 Amyloid Is Regulated by Juxtamembrane Metalloproteinase Cleavage, and the Resulting C-terminal Fragment Is a Substrate for {gamma}-Secretase

M. P. Kummer, H. Maruyama, C. Huelsmann, S. Baches, S. Weggen and E. H. Koo
J. Biol. Chem., January 23, 2009; 284 (4): 2296-2306.

[Abstract] [Full Text] [PDF]

TRPM8 activation suppresses cellular viability in human melanoma

H. Yamamura, S. Ugawa, T. Ueda, A. Morita and S. Shimada
Am J Physiol Cell Physiol, August 1, 2008; 295 (2): C296-C301.

[Abstract] [Full Text] [PDF]

Medline items on this article's topics can be found at <http://highwire.stanford.edu/lists/artbytopic.dtl> on the following topics:

Biochemistry .. Melanin
Endocrinology .. Corticotropin
Cell Biology .. Melanocytes
Oncology .. Adrenocorticotropin
Genetics .. Linear Sequence
Physiology .. Interphase

Updated information and services including high-resolution figures, can be found at:

<http://physrev.physiology.org/cgi/content/full/84/4/1155>

Additional material and information about *Physiological Reviews* can be found at:

<http://www.the-aps.org/publications/prv>

This information is current as of July 25, 2009 .

Melanin Pigmentation in Mammalian Skin and Its Hormonal Regulation

ANDRZEJ SLOMINSKI, DESMOND J. TOBIN, SHIGEKI SHIBAHARA, AND JACOBO WORTSMAN

Department of Pathology, University of Tennessee, Memphis, Tennessee; Department of Biomedical Sciences, University of Bradford, Bradford, West Yorkshire, United Kingdom; Department of Molecular Biology and Applied Physiology, Tohoku University School of Medicine, Sendai, Miyagi, Japan; and Department of Medicine, Southern Illinois University, Springfield, Illinois

I. Melanin Pigment	1156
A. Melanins: chemical and physical properties	1156
B. Melanin pigment in skin physiology and pathology	1158
II. Biochemistry and Cellular and Molecular Biology of Melanogenesis	1160
A. Melanocytes as Melanin-Producing cells: cell biology and ultrastructure	1160
B. Biochemistry of melanogenesis	1163
C. Extrapigmentary functions of melanogenesis-related proteins	1168
III. Mechanisms of Regulation of Melanogenesis	1169
A. Transcriptional regulation	1169
B. Intracellular signal transduction pathways	1169
C. Dual function of L-tyrosine and L-DOPA: reaction substrates and bioregulators	1171
D. Summary	1174
IV. Hormonal Stimulators of Melanogenesis and Their Receptors	1174
A. G protein-coupled receptors and ligands	1174
B. SCF and its receptor	1184
C. Nuclear receptors and their ligands	1186
D. Other positive regulators of melanogenesis: bone morphogenic proteins	1188
E. Summary	1189
V. Hormonal Inhibitors of Melanogenesis and Receptors	1189
A. G protein-coupled receptors and their ligands	1189
B. Melanocortins antagonists	1192
C. Cytokines, growth factors, and receptors	1194
D. Other negative regulators of melanogenesis	1196
E. Summary	1197
VI. Miscellaneous Regulation of Melanogenesis By Nuclear Receptors and Their Ligands	1197
A. Glucocorticoids and their receptors	1197
B. Retinoids and their receptors	1198
C. Summary	1198
VII. Functional Regulation of Follicular (Hair) and Epidermal Melanin Units	1199
A. The epidermal melanin unit	1199
B. Regulation of hair cycle-coupled follicular melanogenesis	1200
VIII. Unified Concept for the Transcriptional Regulation of Melanogenesis: a Key Role for Microphthalmia-Associated Transcription Factor	1201
IX. Melanogenesis as Molecular Sensor and Transducer of Environmental Signals and Regulator of Local Homeostasis	1203
X. Comments and Future Directions	1205

Slominski, Andrzej, Desmond J. Tobin, Shigeki Shibahara, and Jacobo Wortsman. Melanin Pigmentation in Mammalian Skin and Its Hormonal Regulation. *Physiol Rev* 84: 1155-1228, 2004; 10.1152/physrev.00044.2003.—Cutaneous melanin pigment plays a critical role in camouflage, mimicry, social communication, and protection against harmful effects of solar radiation. Melanogenesis is under complex regulatory control by multiple agents interacting via pathways activated by receptor-dependent and -independent mechanisms, in hormonal, auto-, para-, or intracrine fashion. Because of the multidirectional nature and heterogeneous character of the melanogenesis modifying agents, its controlling factors are not organized into simple linear sequences, but they interphase instead

in a multidimensional network, with extensive functional overlapping with connections arranged both in series and in parallel. The most important positive regulator of melanogenesis is the MC1 receptor with its ligands melanocortins and ACTH, whereas among the negative regulators agouti protein stands out, determining intensity of melanogenesis and also the type of melanin synthesized. Within the context of the skin as a stress organ, melanogenic activity serves as a unique molecular sensor and transducer of noxious signals and as regulator of local homeostasis. In keeping with these multiple roles, melanogenesis is controlled by a highly structured system, active since early embryogenesis and capable of superselective functional regulation that may reach down to the cellular level represented by single melanocytes. Indeed, the significance of melanogenesis extends beyond the mere assignment of a color trait.

I. MELANIN PIGMENT

A. Melanins: Chemical and Physical Properties

Melanins, the end-products of complex multistep transformations of L-tyrosine, are polymorphous and multifunctional biopolymers, represented by eumelanin, pheomelanin, neuromelanin, and mixed melanin pigment (323, 597, 598). Melanin biosynthesis can be initiated from either the hydroxylation of L-phenylalanine to L-tyrosine (nonobligatory step, operative in vivo) or directly from

L-tyrosine, which is then hydroxylated to L-dihydroxyphenylalanine (L-DOPA) (obligatory step both in vitro and in vivo). L-DOPA serves as a precursor to both melanins and catecholamines, acting along separate pathways (Fig. 1). The next step, oxidation of L-DOPA to dopaquinone, is common to both eu- and pheomelanogenic pathways (597, 598). Eumelanogenesis involves the further transformation of dopaquinone to leukodopachrome, followed by a series of oxidoreduction reactions with production of the intermediates dihydroxyindole (DHI) and DHI carboxylic acid (DHICA), that undergo polymerization to form

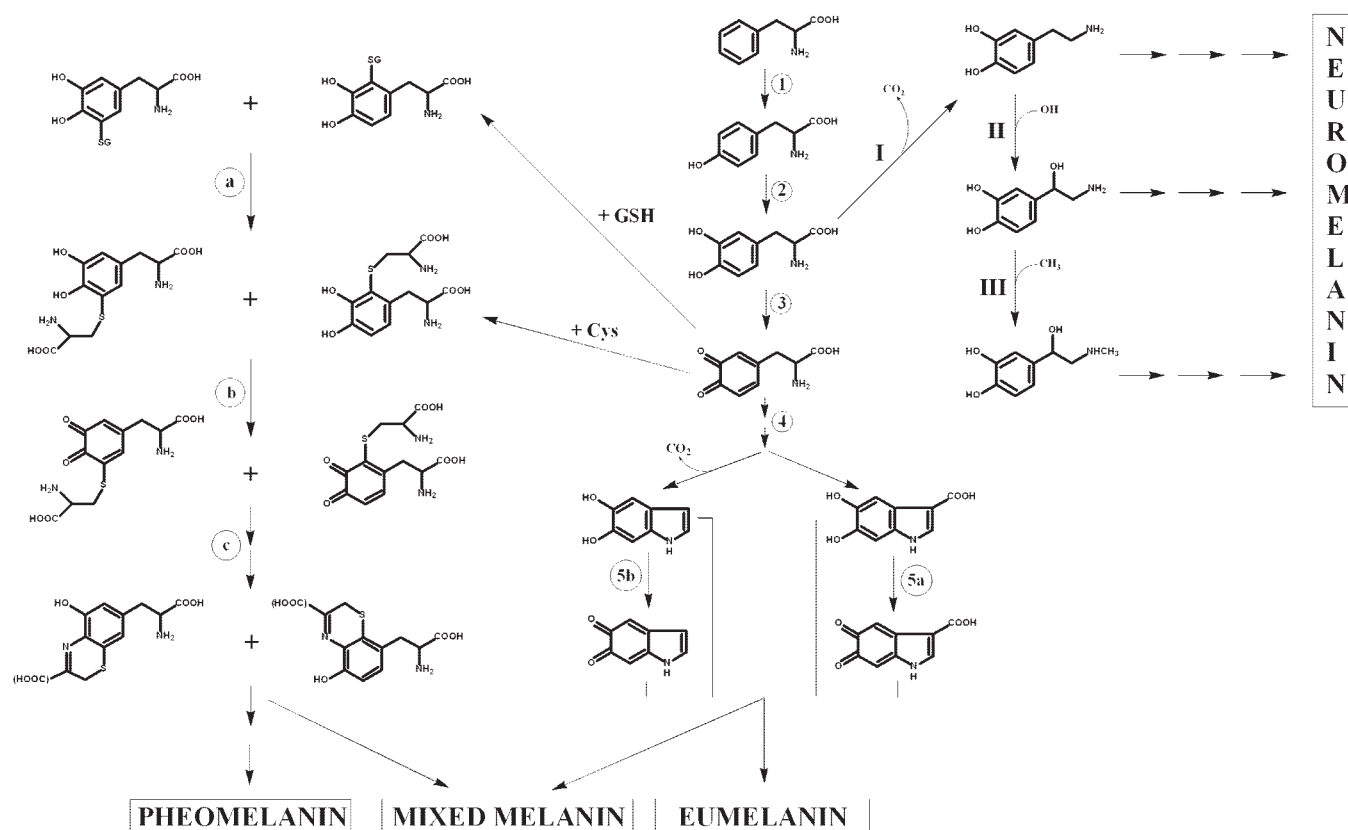

FIG. 1. Synthesis of melanins. GSH, glutathione; Cys, cysteine. *I*: Phenylalanine hydroxylation (by PH); *2*: tyrosine hydroxylation (by either tyrosinase or TH); *3*: DOPA oxidation (by tyrosinase or metal cations); *4*: dopachrome tautomerization (by DCT/Tyrp2 or metal cations); *5a*: DHICA oxidation (by Tyrp1 or peroxidase); *5b*: DHI oxidation (by tyrosinase or peroxidase); *a*: hydrolysis of glutathionyl-dopa (by γ -glutamyltranspeptidase); *b*: oxidation of cysteinyl-dopa (by peroxidase); *c*: intramolecular cyclization of cysteinyl-dopaquinone (may be facilitated by peroxidase); *I*: DOPA decarboxylation (by AAD); *II*: hydroxylation of dopamine (by DBH); *III*: methylation of norepinephrine (by PNMT).

eumelanin (323, 573, 597). Pheomelanogenesis also starts with dopaquinone; this is conjugated to cysteine or glutathione to yield cysteinylDOPA and glutathionylDOPA, for further transformation into pheomelanin (323, 597, 598). Mixed melanin contains both eu- and pheomelanin. L-DOPA generation of catecholamines requires its enzymatic decarboxylation, hydroxylation, and methylation to produce dopamine, norepinephrine, and epinephrine, respectively (790). In vitro, all of these catecholamines can potentially convert into neuromelanin through several oxidation/reduction reactions (Fig. 1) (787); in vivo, only dopamine and cysteinylDOPA can serve as primary precursors to the pigment (101, 151, 930).

Melanin pigments have in common their arrangement of several units linked by carbon-carbon bonds (C-C), but differ from each other in chemical composition, as well as structural and physical properties (323, 597, 598). Thus eumelanins are polymorphous nitrogenous biopolymers (predominantly copolymers of DHI and DHICA), black to brown in color, insoluble in most solvents (597, 598), and tightly associated with proteins through covalent bonds. Eumelanins behave like polyanions with the capability to reversibly bind cations, anions, and polyamines in reactions facilitated by their high carboxyl group content (323, 597, 598). A feature unique to eumelanin is a stable paramagnetic state that results from its semiquinone units (Fig. 2) (61, 126). Thus the electron paramagnetic resonance (EPR) spectrum of eumelanin corresponds to a

slightly asymmetric singlet that generates a free radical signal at approximately $g = 2.004$. The semiquinone units are also responsible for eumelanin actions as redox pigment with both reducing and oxidizing capabilities towards oxygen radicals and other chemical redox systems (126, 597, 598). Both eumelanin physical structure and electrical properties are consistent with its behavior as an amorphous semiconductor (210, 392, 544). Another interesting property of eu- and pheomelanin chemiluminescence is related to oxidative degradation of the melanin pigment (164, 658, 712).

In contrast to eumelanin, pheomelanin has a backbone of benzothiazine units and exhibits a yellow to reddish-brown color and is alkali soluble (323, 597, 598). Pheomelanin is tightly bound to proteins, indicating that in vivo it occurs as a chromoprotein (323, 597, 598), with high variability in nitrogen and sulfur content (C/N and C/S ratios) (597, 598). Pheomelanin can also act as a binding agent for drugs and chemicals (73, 458) and, like eumelanin, contains semiquinones with their associated paramagnetic properties, but it also holds additional semiquinonimine centers (688, 689). The resulting EPR spectra of pheomelanins correspond therefore to a hyperfine structure with an unpaired electron localized near the nucleus of ^{14}N . These properties allow identification of melanin type and quantification with EPR (Fig. 2) (443, 586, 688, 689, 713, 739, 744, 745). Pheomelanins are photolabile, and its photolysis products include superoxide,

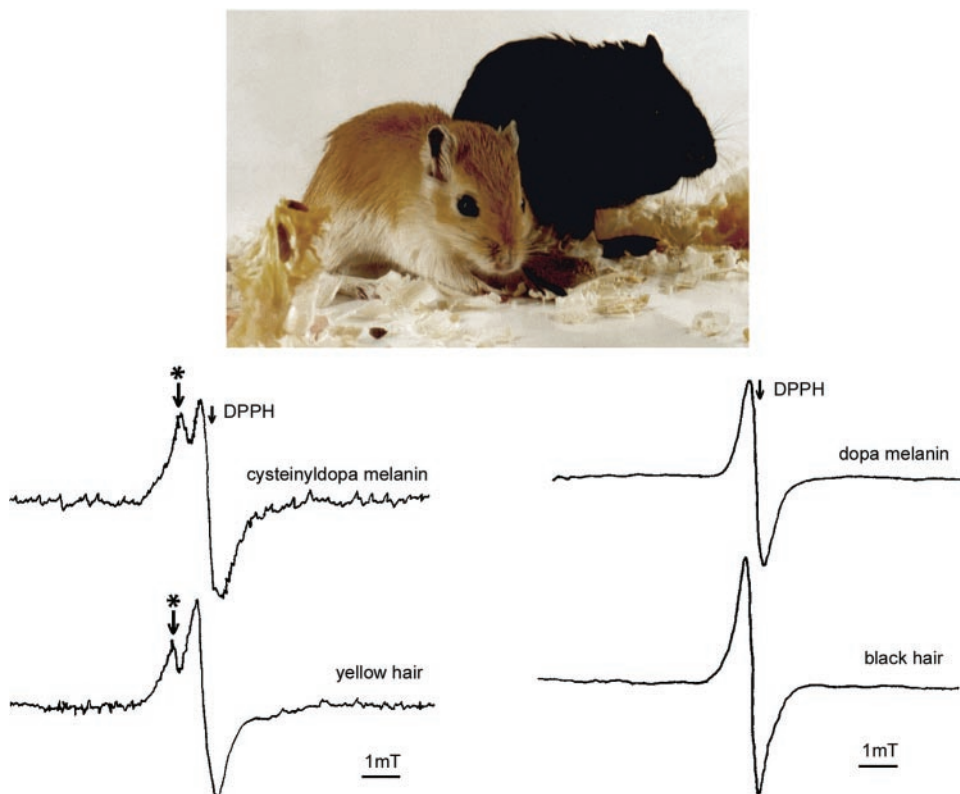

FIG. 2. Electron paramagnetic resonance (EPR) analysis of melanin products in follicular melanocytes from yellow and black gerbils (top). Bottom, left: EPR spectrum of yellow hair showing hyperfine splitting similar to the spectrum of cysteinylDOPA melanin (a synthetic model of pheomelanins). Asterisk indicates low field component of the splitting. Bottom, right: EPR signals of black hair and DOPA melanin (a synthetic model of eumelanins with no hyperfine splitting). The spectra were recorded at -196°C (77°K), at the field of 328 ± 10 mT, modulation amplitude of 0.1 mT, microwave power 8 mW and frequency 9.22 GHz, time constant 0.3 s, and scan time 8 min. Corresponding gains are as follows: 150,000 (yellow hair); 80,000 (cysteinylDOPA melanin); 20,000 (DOPA melanin); 8,000 (black hair). DPPH, 1,1-diphenyl-2-picrylhydrazyl—the position of a free radical signal ($g = 2.0037$). [From Plonka et al. (586), with permission from the Blackwell Munksgaard.]

hydroxyl radicals, and hydrogen peroxide (597, 598). The trichromes B, C, E, and F are pheomelanin-related products containing a basic structure unit consisting of 1,4-benzothiazine that can exist in two tautomeric forms (597, 598).

Neuromelanins are macropolymers composed of aminochromes and noradrenalinochromes (101, 151, 522, 787, 930). Similar to other melanins, neuromelanins are brown/black pigment with stable paramagnetic properties, insoluble in organic solvents, bleached by hydrogen peroxide, and labeled by silver stain (930). Neuromelanins have mixed properties of both eu- and pheomelanins; they chelate metals and interact with several inorganic and organic compounds (9, 151, 428, 930). Other types of melanins may be generated by enzymatic oxidation of serotonin or tryptophan via tyrosinase; the resulting products have structures different from classical melanin (45). Melanin-like substances can also result from the tyrosinase-mediated transformation of opioid peptides that produce black to brown pigments with paramagnetic properties almost identical to DOPA-melanin (633).

B. Melanin Pigment in Skin Physiology and Pathology

1. Human skin

Epidermal melanin has important evolutionary and physiological implications, particularly for unclothed humans. Thus high melanin content (racial pigmentation) protects the skin against ultraviolet (UV)-induced skin damage through its optical and chemical filtering properties (8). Indeed, skin pigment levels and anthropological origin are closely associated, with higher pigment amounts in regions of lower latitude and higher UV radiation levels. However, this connection may only be a recent human adaptation since early hominids may have possessed dark, dense, terminal body hair. A closely related primate, the chimpanzee, similar to most other non-human primates, exhibits white or lightly pigmented epidermis (591). Interestingly, chimpanzees have active melanocytes only in the epidermis of those areas directly exposed to UV radiation, e.g., face and friction surfaces (488).

The tendency toward relative hairlessness in modern humans has been explained by the need to maintain thermal balance under the progressive increase in demands for heat dissipation that results from the enhanced blood flow to the brain. Alternately or complementarily, hairlessness would also reduce parasitic infestations (549). Without concomitant increase in epidermal melanization, the end result of reduced hair coverage in humans residing in high UV radiation areas would be direct exposure to the adverse effects of that radiation. These include sunburn damage to the sweat glands with resultant suppres-

sion of sweating and abnormal thermoregulation (550), carcinogenesis, and nutrient inactivation by photolysis (e.g., folate) (74). Human populations living in areas with lower UV levels would adapt with lesser pigmentation, which also facilitates the cutaneous UV radiation-mediated conversion of 7-dehydrocholesterol to pre-vitamin D₃ (876). In fact, if UV exposure of pigmented humans is limited in duration and/or intensity (e.g., northern latitudes), vitamin D₃ deficiency and its associated pathologies may result, as seen in Southern Asians (Indians) living in northern European cities (267). Nevertheless, the value of the melanin pigmentation as a truly effective sunscreen for seasonal tanning is debatable since its sun protection factor (SPF) is only 1–2 (902). Additional properties of melanin may include a bactericidal potential via the production of orthoquinones (618), and contribution to the tensile strength of hair via cross-linking with proteins.

Hair color may have undergone a far more complex evolution than skin pigmentation. Although most humans are dark-haired and dark-eyed, melanization in skin, hair, and eyes do not closely correlate. Indeed, a large fraction of humans have dark eyes and hair but their skin would rate as “white,” whereas in some western European populations, black hair commonly coexists with blue eyes. The occurrence of black scalp hair, a potent trap for radiant heat, may appear as a paradoxical development for primates and humans living in tropical climates; however, black scalp hair may provide some protection from sunstroke by helping with the salt balance through the highly efficient and fast ion exchange property by melanin (746, 902). In fact, the pigmented hair on the human scalp may have resulted from the littoral residence of *Homo sapiens* residing on sea coasts or riverbanks, with diet dominant in fish (many of which concentrate heavy metals). In this context, the capability to rapidly excrete toxic metals provided by the very high turnover of melanized cortical keratinocytes in the pigmented hair shaft would confer a selection advantage (46). Thus the long, melanized scalp hair with its capability to trap and/or bind chemicals, toxins, and heavy metals would prevent their access to living tissues. Pigmented hair may also provide antioxidant defense for the skin and hair follicles due to the high capacity of melanin for binding transition metals. This buffering capacity as applied to calcium would imply a role for melanin in cell function, since calcium is a critical second messenger in pigmentation signaling, acting in the transfer of melanosome to keratinocytes, and in epithelial cell differentiation (746).

A) SEXUAL DIFFERENCES IN SKIN MELANIZATION. The epidermis of adult human females is less melanized than in adult males, suggesting a gender-specific effect (626). One possible explanation for this discrepancy could be the higher need for vitamin D in women that is imposed by the

increased intestinal calcium absorption of pregnancy and lactation (894).

B) MELANIN ROLE IN HUMAN PATHOLOGY. The main action of melanin in human skin appears to be attenuation of UV penetration to blood in dermal vessels. This may be inferred from the observation that peak UV absorption for oxyhemoglobin occurs at 545 nm, a value that in light-skinned individuals produces the strongest erythema reaction, and consequent pigmentary response. Also, when exposed to UV radiation, melanin can undergo photosensitization generating superoxide radicals and lethal injury in individual cells. Paradoxically, this action would however confer protection against the more deleterious outcome of cell neoplasia, consistent with the decreased proliferation rate of highly melanized normal skin cells (194), and with the close linkage between melanin production and photorepair of UV-induced DNA damage (212). Taken together, these data imply that melanin is important for skin homeostasis and that tanning itself represents a distress signal. The same pathophysiological explanation would apply to the localized pigmentation that follows the exposure of melanin to toxic compounds, and that may result in marked increases in melanin granules and melanin deposition (427).

Abnormalities in the transfer of melanosomes out of the melanocytes and into receiving keratinocytes represent the human counterpart of the dilute mutation in mice where the motor protein myosin V is defective. Disorders associated with aberrant melanosomes include the macromelanosomes and autophagic giant melanosome complexes of nevocellular nevi, lentigo simplex, malignant melanoma, and the neuroectodermal melanolyosomal diseases that include the Elejalde, Chediak, Higashi, and Griscelli syndromes (515, 779, 780). These syndromes are more likely due to disordered melanosome biogenesis than alterations in melanosome degradation.

The most common pigment disorders are not disorders of melanin quality, but rather of the pigment-producing cell itself, which may be reduced in number, absent, or hyperactive and commonly, with regional localization. Hypomelanosis can either be acquired, e.g., vitiligo, or congenital via inheritance of mutations in pigment-related genes, e.g., albinisms and piebaldisms. Pigment excess (hypermelanosis) can be associated with inflammatory responses, as in keloid scars, or with local abnormal melanocyte function, as in dysplastic nevi or malignant melanoma.

C) MELANIN METABOLISM. Intact mature melanosomes pass from basal melanocytes into keratinocytes and their lysosomal compartment to become melanin dust in the upper nonviable layers of the epidermis. There is scant information on the actual mechanism of melanin breakdown or biodegradation. The melanin polymer appears to be resistant to enzymatic lysis, and it has been speculated that only phagosomal NADPH oxidase can degrade mel-

anin itself via oxidative attack (68). Nevertheless, hair melanin granules, unlike those in overlying epidermis, tend to remain intact in the hair shaft. This is especially true for the eumelanogenic melanosomes of the black hair shaft such as seen in the hair of East-Asian (Oriental) individuals, the ethnic group with the highest density of pigment granules. In contrast, the pheomelanin granules characteristic of red and blonde hair, are partially digested. Both melanin types can be synthesized and released by the same melanocyte.

2. Furry mammals (rodents)

Most of the information on skin pigmentation has emerged from the intensive study of rodent coat color, as opposed to research focused specifically on epidermal pigmentation. As a uniquely mammalian trait, hair serves important functions most easily appreciated in furred mammals. These include thermal insulation, camouflage (for many species, melanin affords significant additional protective value, e.g., seasonal change of coat color in the arctic fox), social and sexual communication (involving visual stimuli, odorant dispersal, etc.) and sensory perception (e.g., whiskers). Many furred mammals, including the mouse, lack melanogenically active melanocytes in their adult truncal epidermis; instead, melanin is produced in the hair follicle bulb. There is, however, considerable variation in pigment patterns within and between furred mammals; for example, perifollicular melanocytes extend to the dermis in the hairy truncal skin of the adult Syrian golden hamster (602).

Mammalian hair color exhibits a wide range of shades. The highly variable color of murine pelage reflects variation in the copolymerization of eu- and pheomelanins, which results in the production of black, brown, yellow, gray, or white hair fibers. Natural eumelanins are produced by comixtures of DHI and DHICA, which provide variable contributions to pigmentation. For example, dilution mutant mice (e.g., slaty) exhibit a 30% reduction in total melanin compared with the black hair type, but the specific reduction in DHICA content can be >80% (548). DHICA melanins determine brown colors in the animal kingdom (538), although the ratio of DHI to DHICA in the brown mutation is similar to that seen in the black hair type. The light mutation at the brown locus results in the presentation of melanin only at the hair fiber tips due to premature death of follicular melanocytes (339). The silver mutation in mice is also associated with progressive graying caused by loss of melanocytes. Silver melanin is similar to brown and light melanins in those light-silver animals producing a diffuse "soluble" melanin within degenerating melanocytes.

Studies performed on the yellow (*Ay/a*) mouse and on the tortoise-shell guinea pig, with its potential to develop black, red, yellow, or white hair, have shown that

the variation in melanin color is due to relative levels of glutathione reductase activity. Lowest levels are associated with black eumelanin hair, while highest levels are found in animals with lighter colors, and largely pheomelanosomes (40). Many of these color patterns map genetically to the extension locus (see elsewhere in this review). However, hair shaft color reflects not just the quantity and quality of the pigments produced by hair bulb melanocytes, but also the manner in which they are transferred to the hair shaft. Thus mouse coat color mutations, besides being associated with differences in melanin synthesis, can also be due to abnormalities in the formation of the melanosome and their transference to keratinocytes. These mutations are detected on qualitative and quantitative electron microscopy (224). For example, the albino locus is associated with a reduction in melanosome size, but data suggest that the albino locus, in addition to involve that structure, also has a functional (tyrosinase) role in the differentiation of mouse hair-bulb melanosomes. Data on melanosome length-to-width ratios indicate that the agouti locus determines melanosome shape, either spherical or elliptical. The agouti locus, even in the absence of melanization, directs melanosome shape via synthesis and deployment of agouti-locus-encoded matrix proteins, or via other structural actions.

Abnormal transfer of melanin granules into the hair shaft can also lead to variation in pigmentation of mouse coat. An example of this is the dilute mouse, where reduction in coat color is due to mutation of the gene encoding for myosin Va (885). Thus, whereas mature melanosomes of normal melanocytes are located at the dendrite tips, in dilute mice they are retained in the perinuclear region of the cell due to a defect in protein motor capacity to transport melanosome along the cytoskeletal tracks to the dendrite tips. The discovery of this mouse gene, later identified as the first candidate gene for the Griscelli locus (Griscelli syndrome patients display severe immunodeficiency with diluted hair pigmentation), has stimulated a new field of study concerned with the function of molecular motors in vesicle/organelle transportation (849).

II. BIOCHEMISTRY AND CELLULAR AND MOLECULAR BIOLOGY OF MELANOGENESIS

A. Melanocytes as Melanin-Producing Cells: Cell Biology and Ultrastructure

Under physiological conditions, melanin synthesis in melanocytes is restricted to melanosomes, and its enzymatic and structural elements are organized and assembled separately in a process resembling lysosome formation (333, 335, 487, 515, 597), although membrane traffic pathways differ between melanosomes and lyso-

somes (187). In general, melanosome structure correlates with the type of melanin produced, e.g., eumelanosomes are elliptical and contain fibrillar matrix while pheomelanosomes shape is variable with predominantly rounded contour and contains vesiculoglobular matrix (515). Melanosome development involves four steps. Stage I corresponds to the early matrix organization. In stage II, the matrix is already organized but without melanin formation (eumelanosomes); in pheomelanosomes melanin is already formed at this stage. In stage III there is deposition of melanin. In stage IV, melanosomes are fully melanized (completely filled with melanin) (Fig. 3). Under pathological conditions (e.g., melanoma), this orderly process is deregulated; for example, tyrosinase may already be activated at stage I of melanosome formation, whereas melanin can be deposited within organelles as a "granular type" without fibrillar or vesiculoglobular matrix (65, 334). These granular melanosomes produce eumelanin (Fig. 3C). There is no evidence for differences in melanosome biogenesis between follicular and epidermal melanocytes. Thus, in black hair follicles, melanocytes contain the largest number and most electron-dense melanosomes (eumelanosomes), each with a fibrillar matrix; in brown hair, bulb melanocytes are somewhat smaller, and in blonde hair melanosomes are poorly melanized, often with only the melanosomal matrix visible. Red hair pheomelanosomes contain a vesicular matrix, but melanin is deposited irregularly, in blotches (Fig. 3). Of interest, both eumelanogenic and pheomelanogenic melanosomes can coexist in the same human cell (316), but not within the same pathway, e.g., there is a switch committing melanosomes to either eu- to pheomelanin synthesis (547). These structural principles apply to follicular melanocytes and also probably to human epidermal melanocytes and rodent cutaneous melanocytes (181, 515).

Melanosome-genesis involves interactions between rough endoplasmic reticulum (RER) structures and vesicles and channels of the *trans*-Golgi Network (TGN); thus early premelanosomes (stage I) are formed by outpouching of a smooth membrane from the RER (487, 515, 782), and at stage II of the eumelanogenic pathway a fibrillar matrix is formed. It was recently proposed that late endosomes may be the initial sites of stage I melanosome formation (333, 335, 456, 608); further maturation would be driven by delivery of structural and enzymatic proteins, and by their activation followed by substrate delivery. Others believe that formation of melanosomes is driven by independent, but overlapping, mechanisms (384). Maturation of eumelanosomes is the subject of two main views. One suggests that the enzymatic proteins required for melanogenesis are delivered via coated vesicles to melanosomes that originate from the endoplasmic reticulum and Golgi (335). An alternate interpretation is

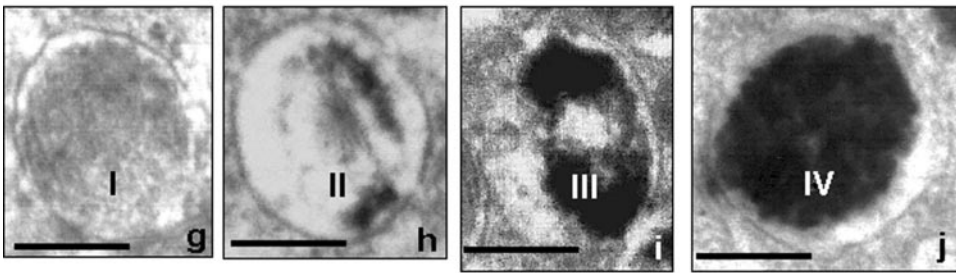
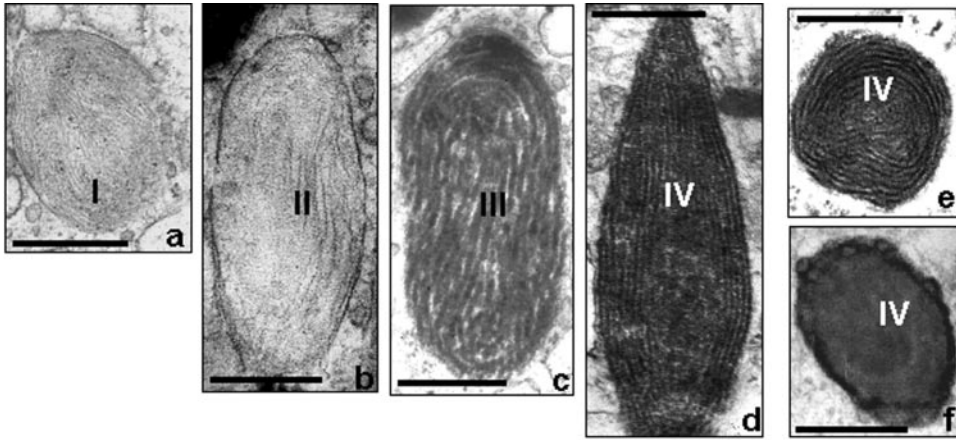
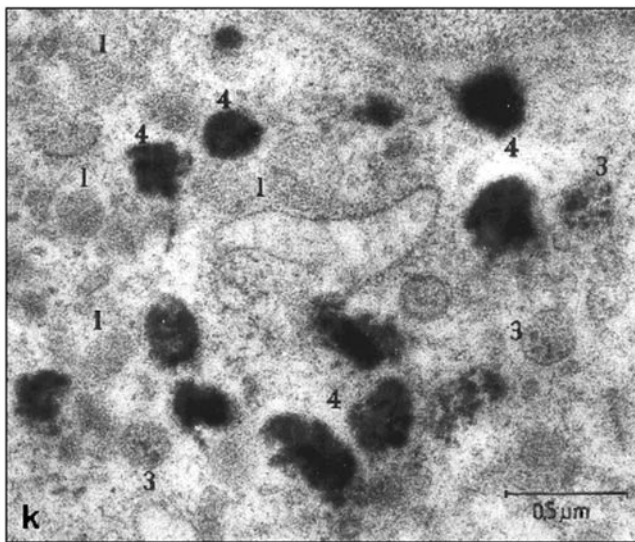

FIG. 3. Electron microscopy of melanosome development during eumelanogenesis in normal melanocytes (*a-f*), of pheomelanogenesis (*g-j*), and of granular melanosomes in melanoma cells that synthesize eumelanin (*k*). I, II, III, and IV in *a-j* and 1, 3, and 4 in *k* represent stages of melanosomal development. Scale bars are as follows (in μm): *a*, 0.20; *b*, 0.23; *c*, 0.24; *d*, 0.22; *e*, 0.20; *f*, 0.35; *g*, 0.23; *h*, 0.26; *i*, 0.26; *j*, 0.30; *k*, 0.5.



that tyrosinase and other melanogenesis-related proteins are sorted to early endosomes by the adaptor protein-3 system (from the TGN) and from there to late endosomes, which then fuse with stage I melanosomes (384). Stage I melanosomes may contain some melanogenesis-related proteins (MRPs), but these remain catalytically inactive until subsequent protein cleavage events release them into the interior of melanosomes. These events are associated with a change in melanosome shape, from spheri-

cal to ellipsoidal, and with the formation of an intramelanosomal fibrillar network (eumelanosomes). Melanogenesis commences when tyrosinase and other relevant enzymes are cleaved, and initiation of activity may depend on an acidic environment provided by proton pumps (454, 601). It is believed that at acidic pH fully mature tyrosinase hydroxylates L-tyrosine to L-DOPA to begin melanin synthesis forming stage III melanosomes (454, 487, 515, 537, 538).

Another theory postulates earlier involvement of tyrosine hydroxylase to produce L-DOPA that acts as a necessary cofactor for tyrosinase enzyme action (457). The initial hydroxylation reactions, as well as L-DOPA stability, require an acidic environment that is provided by premelanosomes, where pH is regulated by a proton pump system (145, 487, 601). However, once L-DOPA is present, efficient formation of melanin pigment requires an increased pH (preferably neutral or basic) (19, 191), since acidification inhibits melanin synthesis (191, 487). The mechanism(s) for delivery of MRPs is under intensive investigation, and the timing of their actual incorporation into melanosomes is still unclear. Proper folding and assembly of MRPs in the ER requires their interaction with calnexin, glycosylation in the TGN, and the interaction of tyrosinase with TyrP1 or P protein (262, 385). MRP transport requires the formation of special vesicles, with assembly of coat proteins on the cytoplasmic side of the TGN to select MRPs for melanosomal delivery (333, 692). The adapter protein-3 (AP-3) that binds a dileucine motif in the cytoplasmic tail of tyrosinase-related proteins (TRPs) is important for the transport of TRPs from the TGN to melanosomes (335, 692). Small GTP binding proteins such as Rab 5 and 7, and phosphatidylinositol 3-kinase are involved in the intracellular trafficking of MRPs (333). An updated model of melanosome formation and trafficking of MRPs (Fig. 4) (132) includes tyrosinase, TyrP1, TyrP2, MART-1, P and gp100, and also the pathological misrouting of tyrosinase and TyrP1 (385). Proteomic analysis of early melanosomes has provided new information on the recruitment of organelle specific proteins and on membrane remodeling crucial for melanosome formation, movement, and transfer (Fig. 5) (33).

The recently cloned pink-eyed dilution mouse gene (*p*) and its human P homolog encode a melanosomal protein with 12 transmembrane domains with partial homology to a tyrosine specific transporter protein in *Esch-*

erichia coli (204, 620). Mutations in this gene lead to decreased pigmentation in mice (620) and to type II oculocutaneous albinism in humans (OCA2) (204). It has been proposed that P protein could act as transporter for tyrosine (204, 620), as ion exchange protein in the melanosomal membrane (601), or as regulatory protein for the processing and assembly of MRPs (539). Alternatively, P protein could act as specific "L-tyrosine receptor/transducer" (736, 739) after binding L-tyrosine or related molecules; thus it would regulate the assembly of the melanogenic apparatus in vivo (293, 720, 732–734). This would be consistent with the homology of the P protein to the tyrosine specific transporter (204, 620), and with the proposed regulatory role for P protein in the assembly of the melanogenic apparatus (539).

Melanosomes also contain the lysosome-associated membrane proteins (LAMP) that protect the lysosomal membrane (333, 335, 654) and, as already mentioned, the presence of LAMP-1, -2, and -3 proteins in melanosomes supports a common ancestral origin for melanosomes and lysosomes. It has been suggested that LAMP-1 protects melanosomal integrity by acting as a scavenger of free radicals produced during melanogenesis, while the membrane-bound calcium binding protein calnexin (p90) of 90 kDa would participate in the assembly of melanosomal proteins and regulation of tyrosinase (335, 654). Melanosomes contain a proton pump that allows regulation of intramelanosomal pH; melanosomes also internalize cell surface melanocyte-stimulating hormone (MSH) receptors via the endocytic pathway (487). These properties together with the incorporation of lysosomal enzymes such as acid phosphatase and the lysosomal protective protein LAMP strengthen the view that lysosomes and melanosomes share a common pathway of organogenesis (333, 335, 487, 607, 654). The MSH-induced delivery of MSH receptor to melanosomes points to a possible intra-

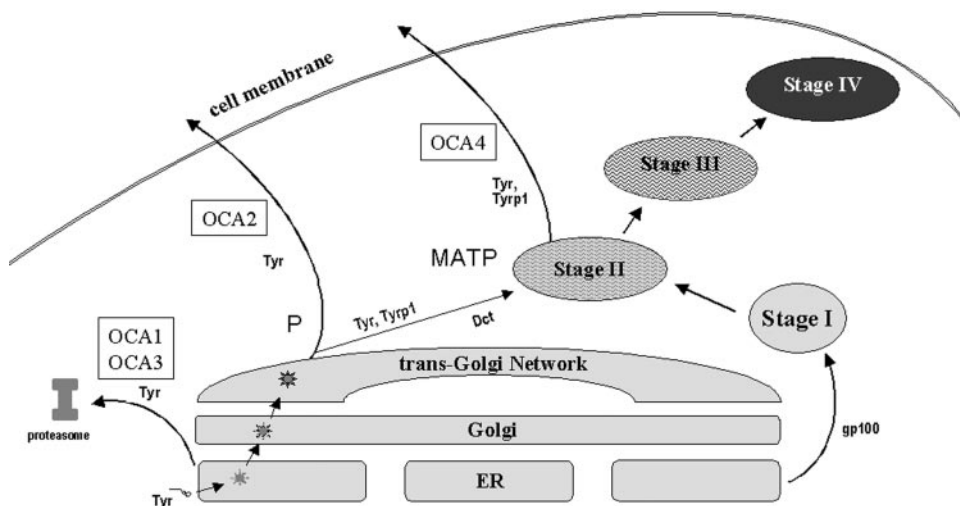

FIG. 4. Trafficking of melanogenesis related proteins to melanosomes (stages I–IV) and misrouting in albinism (OCA1–3). [From Costin et al. (132), with permission from the Company of Biologists Ltd.]

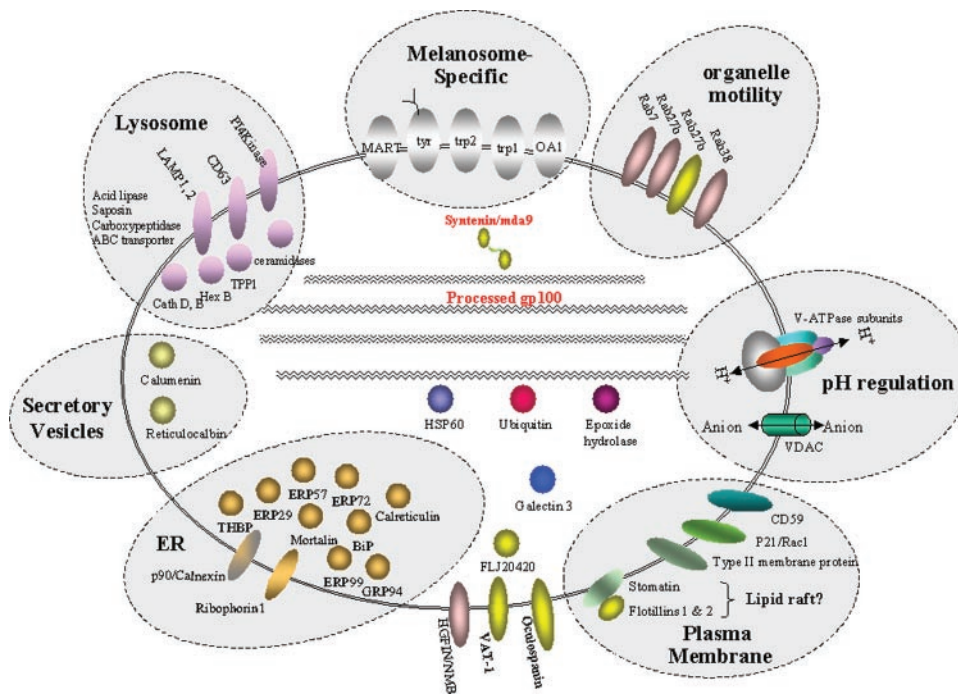

FIG. 5. Melanosome proteomics. Protein components are divided according to function and origin. [From Basrur et al. (33), with permission from the American Chemical Society, copyright 2003.]

cellular mechanism for specific and precise regulatory function of MSH (415, 487, 561).

The mechanism of pheomelanosome formation is less precisely defined than for eumelanosomes. Briefly, vesiculoglobular bodies are incorporated into stage I melanosomes. At stage II melanosomes, pheomelanin is deposited on a vesiculoglobular matrix (333, 335, 515, 597, 708), indicating the presence of tyrosinase activity at an earlier phase than in the eumelanogenic pathway. The process of pheomelanogenesis depends on the presence of tyrosinase activity, which is comparatively low, and on the availability of cysteine to conjugate dopaquinone formed by tyrosinase action (515, 597, 598).

Because melanosomes are metabolically active organelles, their activity is bound to affect the function of the host melanocyte or keratinocyte (746). Thus melanosomes modify the cellular energy-yielding metabolism by switching oxidative catabolism to anaerobic glycolysis (684), altering the intracellular NAD/NADH and NADP/NADPH ratios (682) and/or stimulating the pentose phosphate pathway (683). The presence of pigment granules that can regulate intracytosolic calcium concentration, or reversibly bind cations or bioregulatory compounds such as catecholamines, serotonin, and prostaglandins, may also affect the function of the host cell (736, 746). Based on this, it has been further proposed that melanosomes could serve as an accurate indicator for cellular responses to the environment (262). Results of proteomics analyses appear to support the notion that melanosomes are complex organelles (Fig. 5) (33) that regulate the function of melanocytes and perhaps other surrounding cell types (262, 385, 736–738, 746).

B. Biochemistry of Melanogenesis

1. Introduction to melanogenesis

Cutaneous pigmentation is under complex genetic control regulated by more than 150 alleles spread over 90 loci (262, 263, 328, 385, 515, 673, 708). Protein products of these loci acting as enzymes, structural proteins, transcriptional regulators, transporters, receptors, and growth factors have a wide array of functions and cellular targets (263, 515). Among them are the important structural, enzymatic, and regulatory melanosomal proteins coded by albino(c)/TYR, brown(b)/TYRP1, slaty(slt)/TYRP2/DCT, silver(slt)/SILV, pink-eyed dilute(p)/P/OCA2, underwhite(uw)/LOC51151, MART1, and OAI1 loci (263, 515).

An early obligatory and rate-limiting step in melanogenesis is the hydroxylation of L-tyrosine to L-DOPA catalyzed by either the tyrosine hydroxylase activity of tyrosinase (EC 1.14.18.1) (264, 413, 464, 575, 597) or possibly by tyrosine hydroxylase itself (457). Once L-DOPA is formed, further steps of melanogenesis (series of oxidoreduction reactions and intramolecular transformations) can occur spontaneously, at varying rates depending on hydrogen ion concentration, presence, and concentration of metal cations, reducing agents, thiols, and oxygen (597). Most importantly, the velocity and specificity of the pathway are regulated by the melanogenesis-related enzymes (MREs) of which the most important is tyrosinase (264, 575, 597).

The availability of L-tyrosine for enzymatic oxidation is a central component of melanogenesis, regulated at the

level of transport both through the plasma membrane, and from the cytosol into the melanosome (592, 593). Another source of L-tyrosine, L-phenylalanine (taken up actively by melanocytes via neutral amino acid Na^+ - Ca^{2+} -ATPase antiporter system) (673, 790) and hydroxylated by phenylalanine hydroxylase (PAH) (EC 1.14.16.1) can generate relatively high intracellular concentrations of L-tyrosine, sufficient to initiate melanogenesis (673, 676). Thus initiation of melanogenesis is dependent on either transport of L-tyrosine from the extracellular space or intracellular hydroxylation of L-phenylalanine by PAH regulated by availability of reduced tetrahydropteridine cofactor (661, 670, 673).

The type of melanin produced is determined by the enzymatic library available and its prevalent metabolism (Fig. 1). For example, in the central nervous system, enzymatic decarboxylation of DOPA by aromatic amino acid decarboxylase (AAD) yields catecholamines that may be oxidated to neuromelanins. It is nevertheless unclear whether oxidation of catecholamines in substantia nigra with transformation into neuromelanins is catalyzed enzymatically or whether it is dependent on physicochemical factors (e.g., pH, presence of metal cations, and thiols concentration) (930). The involvement of macrophage inhibitory factor in the formation of neuromelanin has been already demonstrated (262, 467, 638, 664), but not the involvement of peroxidase (930). In melanocytes, the presence of tyrosinase allows rapid oxidation of tyrosine or L-DOPA to dopaquinone, initiating eumelanogenesis pathways. Similarly, high concentrations of metal ions such as Mn^{2+} or Cu^{2+} also rapidly oxidized DOPA to melanin. Metal cations such as copper, zinc, and iron are also involved in the rearrangement of dopachrome to DHICA, thus affecting the composition of the melanin polymer (597, 598).

The formation of eumelanin is directly determined by the presence/absence of cysteine (actively transported through the melanosomal membrane) (262, 594, 597, 598), and of GSH in fully reduced thiolate state and redox potential (high GSH for eumelanin and low for pheomelanin). Therefore, the presence and actual activity in the melanocyte of antioxidant enzymes such as catalase, superoxide dismutases, glutathione peroxidase, glutathione reductase, and thioredoxin reductase/thioredoxin would modify quantitatively or qualitatively the melanogenic pathway (664). When concentration of sulfhydryl compounds is low, dopaquinone is converted to dopachrome, initiating the eumelanogenic pathway. High concentrations of cysteine and glutathione lead to their conjugation with dopaquinone and corresponding formation of cysteinyl-dopa (5-S-cysteinyl-dopa is the major isomer while 2-S-cysteinyl-dopa, 6-S-cysteinyl-dopa, and 2,5-dicysteinyl-dopa are minor isomers) and glutathionyl-dopa (597, 598). The transformation of oxidized glutathione (GSSG) to reduced glutathione (GSH) by glutathione re-

ductase, which requires NADPH, is crucial for the formation of glutathionyl-dopa (GSDOPA). Hence, the NADPH/NADP recycling system and consequently the pentose phosphate shunt are indirectly involved in the regulation of melanogenesis (682, 683). GSDOPA is further transformed by glutamyltranspeptidase to cysteinyl-dopa (323), which serves as the starting point of pheomelanogenesis. The velocity of the postcysteinyl-dopa steps of pheomelanogenesis is increased by peroxidase and tyrosinase through oxidative transformation of benzothiazinyl-lanines (597, 598).

2. Tyrosinase, the main enzyme regulating melanin synthesis

The key regulatory enzyme of melanogenesis, tyrosinase (EC 1.14.18.1), is encoded by the TYR or c-locus that maps to chromosome 11q14–21 in humans (32) and chromosome 7 in mice, respectively, and is composed of five exons and four introns (387, 515, 820). The posttranscriptional processing of pro-tyrosinase mRNA generates several alternatively spliced products (351, 407, 590, 702) of which some are translated to protein products with only one expressing tyrosinase activity (500, 642). It has been proposed that products of translation of alternatively spliced tyrosinase mRNA could serve as regulatory protein (736, 739), acting for example as “receptors” for L-tyrosine and L-DOPA (739). It must be noted that enzymatically nonfunctional tyrosinase proteins can be expressed in nonmelanocytic cells of neural crest origin (254, 826).

The structure of tyrosinase protein is highly conserved among different species and shows high homology with other tyrosinase-related proteins including tyrosinase-related protein 1 (TRP1/TYRP1) and tyrosinase-related protein 2 (TRP2/TYRP2/DCT) (Fig. 6). The NH_2 -terminal domain of tyrosinase comprises the NH_2 -terminal signal peptide (important for intracellular trafficking and processing), the EGF-like/cysteine-rich domain, two histidine-rich regions binding copper with a cysteine-rich region between them (the important catalytic domain), as well as the COOH-terminal hydrophobic transmembrane segment and cytoplasmic tail (387, 389, 515, 702). The transmembrane and cytoplasmic domains are necessary for targeting the enzyme to the melanosome (333, 335, 692), while the NH_2 terminus cysteine-rich region may serve as a protein binding/regulatory domain unrelated to enzymatic function. Newly synthesized tyrosinase has a molecular mass of 55–58 kDa and an isoelectric point of 4.2. Proper folding of tyrosinase protein in the endoplasmic reticulum (ER) appears to be crucial for its further transport to Golgi apparatus. Proteolytic cleavage of the transmembrane portion of the newly synthesized enzyme generates two soluble molecular forms: a 53-kDa unmodified protein, or a 65-kDa glycosylated tyrosinase, which

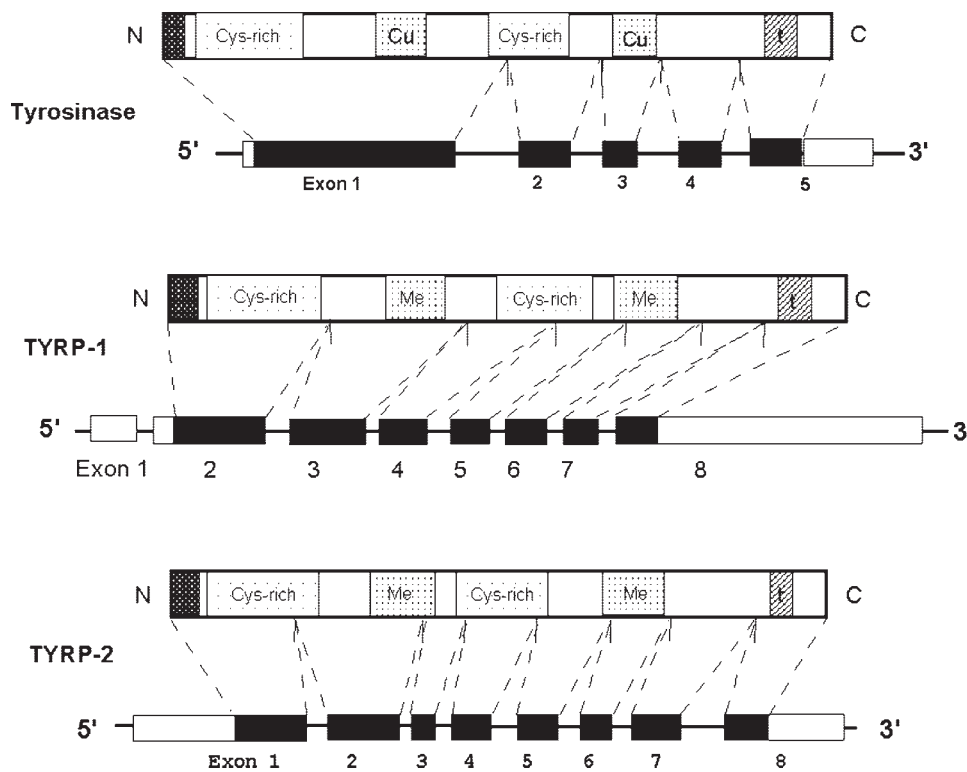

FIG. 6. Gene and protein structures of tyrosinase, TYRP1 and TYRP2. N and C are the amino and carboxy protein terminus, respectively; Cys-rich, cysteine-rich segments; Cu or Me, Cu or metal binding domains; t, transmembrane segment. In the gene structure, numbers represent exons.

may be active in the melanosome or secreted into the extracellular environment. After glycosylation in the *trans*-Golgi complex, tyrosinase increases in size to 65–75 kDa or even 80 kDa (140, 141, 264, 335, 655). The higher molecular mass forms of tyrosinase (140, 655, 720, 722, 741) may represent dimmers, tight complexes with other melanogenic proteins (542), or high-molecular-weight tyrosinase proteins. It is still unclear how or when copper ions (necessary for enzymatic activity) are integrated into apotyrosinase. However, recent data suggest that the Menkes copper transporter (MNK) is required for copper loading of tyrosinase enzyme and consequently its activation (581). The catalytic site of tyrosinase is represented by two copper atoms ligated to six histidine residues.

Defects in TYR gene lead to the tyrosinase negative oculocutaneous albinism type 1 (OCA1) (524, 809, 838). In addition to mutations in hot spots (copper binding domains), virtually the entire coding sequence of the gene is susceptible to mutations. These include missense, nonsense, frameshift, and splicing abnormalities (524) (<http://www.cbc.umn.edu/tad>). If translated, mutant tyrosinase proteins are routed for degradation by proteasomes (due to the retention of misfolded proteins in the ER), rather than allowed to pass to the Golgi apparatus for glycosylation and further transport to premelanosomes (244, 246, 249, 385, 841, 842). Similarly in OCA3, mutated TYRP1 is retained within ER and appropriate processing of normal tyrosinase is aborted leading to its proteasomal degradation and consequently significantly reduced pigmentation

(385, 841, 842). In OCA2 (mutation of P) or OCA4 (mutation of MATP) tyrosinase sorting from TGN to melanosomes is also disrupted (115, 132, 385, 840). There is also a large body of experimental evidence generated in various melanocytes systems, showing that proper processing within the ER is a necessary step for tyrosinase maturation, its targeting to melanosomes, and consequently melanin pigment production (243, 244, 246, 248–250). Thus the defects underlying OCA1 through OCA4 strongly imply that *in vivo* melanogenic activity depends mainly on posttranslational pathways, of which the most important is effective processing of tyrosinase (Fig. 4). In fact, the levels of tyrosinase mRNA are similar in cultured melanocytes from European white and African black individuals (318), and tyrosinase gene expression level appears to be similar across human racial groups (191, 324). Other points of potential dysregulation of the melanogenic activity of tyrosinase are represented by lack of melanosomes with resulting accumulation of the enzyme in TGN or block in translocation from TGN to melanosomes (65, 714, 733), presence of intracellular tyrosinase inhibitors (344) or protein kinase-dependent phosphorylation of regulatory residues (373, 552, 900).

Tyrosinase catalyzes three distinct reactions in the melanogenic pathway: hydroxylation of monophenol (L-tyrosine), dehydrogenation of catechol (L-DOPA), and dehydrogenation of DHI; L-DOPA serves as cofactor in the first and third reactions (264, 374, 413, 575). Both ortho hydroxylation of tyrosine and dehydrogenation of DOPA

may proceed in a single step in which the substrate binding site for L-tyrosine and L-DOPA is the same, and the reaction involving electrons exchange with copper atoms generates orthoquinone and water as final products (reviewed in Refs. 400, 401, 515, 619). It has been proposed that production of DOPA during tyrosine oxidation by tyrosinase is the result of spontaneous reductive cyclization of dopaquinone to cycloDOPA that undergoes redox exchange with dopaquinone to yield dopachrome and DOPA. The latter is necessary for copper reduction and formation of deoxytyrosinase. Thus the stability, folding, and activation of tyrosinase are critically controlled by redox conditions. Activation of inactive enzyme (met-tyrosinase) involves the reduction of its two Cu^{2+} sites to two Cu^{1+} centers (fully active form; deoxytyrosinase) requiring a two-electron reduction step. L-DOPA is the most efficient electron donor necessary to start tyrosine hydroxylation, although ascorbic acid, dopamine, and superoxide anion radicals can potentially activate the enzyme (903). The effect of ascorbic acid on the monophenolase activity of tyrosinase has been explained by its reducing action on enzymatically generated quinines, thus inducing accumulation of L-DOPA, the main electron donor to the Cu^{2+} - Cu^{2+} enzyme active site (629). A similar mechanism may be responsible for the reduction in lag period for tyrosine hydroxylation by catecholamines, by reduced tri- and diphosphopyridine nucleotides, and by high concentrations of tetrahydropteridine (587). However, these explanations may be valid only at relatively high pH (6.8 or higher), since at low pH (5.0), tyrosine hydroxylation proceeds independently of L-DOPA (in the presence of ascorbic acid as the only reductant). At acid pH tyrosine loses its ability to bind at its allosteric site and cresolase activity is not inhibited by excess of tyrosine (145) and since DOPA oxidase activity is inhibited by acidic pH the excess of L-DOPA could escape catalytic site and diffuse to other cellular compartments. Tyrosinase activity can also be inhibited by interactions with cysteine, by chelation of copper ions, by competitive occupancy of the catalytic site (for example, by L-phenylalanine), by feedback inhibition by intermediates of melanogenesis, and by direct inactivation by melanin pigment. Tyrosinase activity *in vitro* is thus regulated by the local chemical environment and, by the process of melanogenesis itself including its final product melanin.

3. TRP1 and TRP2 as modifiers of pathway velocity

Two additional TRPs stimulate eumelanin synthetic rate: TRP1, product of TYRP1 (human) or b (mouse) locus, and TRP2 product of TYRP2/DCT (human) and slaty locus (mice). The gene for TYRP1 is 37 kb long and contains eight exons separated by seven introns (515, 656). The TYRP1 proteins is encoded by exons 2–8, with exon 1 containing a noncoding sequence (329, 700). How-

ever, functional analysis of the human TYRP1 promoter showed that the downstream region, containing 5-untranslated region (exon 1) and intron 1 had enhancer activity for the gene (703, 704). Alternative splicing of TYRP1 pre-mRNA generates at least two isoforms, one coding for the correct protein and another containing a deletion of 103 bp at the 5'-end of exon 8 to generate soluble TYRP1 protein without transmembrane domain because of frame shift (700). The potential for production of multiple alternatively spliced isoforms had been predicted based on analysis of the TYRP1 gene sequence (329). The gene for TYRP2 is 60 kb long and contains at least eight exons and seven introns; all eight exons encode the final protein (84). Similar to TYR and TYRP1, TYRP2 transcription and processing also generates several alternatively spliced forms (356, 445, 585). These include the correct TYRP2 mRNA, and the isoforms TYRP2-6b (contains an in frame insertion of two novel exons from intron 6), TYRP2-INT2 (retains an intron 2 with stop codon), TYRP2-LT (has an extended 3'-untranslated end), and TYRP2-8b (contains a novel exon 8b replacing exon 8) (356, 445, 585). TYRP2-LT codes for a protein identical to TYRP2. TYRP2-6b codes a protein with sequence almost identical to TYRP2 with the in-frame insertion of 33 amino acids; most likely this represents a fully functional enzyme. The remaining TYRP2-INT2 and TYRP2-8b isoforms correspond to truncated enzymatically inactive soluble proteins without transmembrane domains (445, 585).

TYRP1 and TYRP2/DCT proteins share ~40% amino acid homology with tyrosinase, with which they also have structural similarity (84, 329, 387, 515, 700). The proteins contain an NH_2 -terminal signal sequence, EGF-like domains, and other cysteine-rich region, two histidine-rich metal binding domains, and a COOH-terminal transmembrane segment with short cytoplasmic tail. However, different exons code for different homologous segments in tyrosinase and tyrosinase-related proteins (Fig. 6). In TYRP2, the metal binding domain binds zinc, while in TYRP1 it weakly binds iron. The COOH terminus and transmembrane domains are crucial for targeting the enzyme to the melanosome. Newly synthesized TYRP1 and TYRP2 have ~55 kDa molecular mass and after posttranslational folding are targeted to the Golgi apparatus for further processing (262, 333, 335, 385). Mature and glycosylated proteins of 70–75 kDa are sorted from the Golgi apparatus to melanosomes. Because of the presence of sequences homologous to EGF in TYRPs, they can form multimeric complexes of 200–700 kDa, which may be important in the regulation of melanogenesis (330, 452, 542), or in the synthesis and assembly of the melanogenic apparatus (452, 736, 739).

In the mouse, TYRP1 acts as a DHICA oxidase to generate indole-5,6-quinone-carboxylic acid (329, 336, 368). However, some authors have proposed that TYRP1

does not catalyze the reaction in humans exhibiting instead tyrosine hydroxylase activity at low concentration of substrate (62). TYRP1 activity appears to be important for eumelanogenesis, as suggested by its lack or defective expression in cells displaying an active pheomelanogenic pathway (142, 722). An additional function of TYRP1 may be the securing of appropriate processing of tyrosinase (see above) and stabilization of its enzymatic activity and, possibly, maintenance of melanosomal structure integrity (262, 410, 656, 657). TYRP-2 acts as dopachrome tautomerase (EC 5.3.2.3) catalyzing transformation of dopachrome to DHICA (330, 843, 920). TYRP2, similar to TYRP1, is considered to be a eumelanogenic enzyme and also stabilizes tyrosinase activity. Most recently, a role for TYRP2 in melanocyte survival has been demonstrated (reviewed in Ref. 262). Thus both TYRP1 and TYRP2 can act as enzymes modifying eumelanogenesis velocity, as regulators/stabilizers of the eumelanogenic apparatus *in vivo* and, perhaps, as regulators of other functions of the melanocyte.

4. Tetrahydropteridines, phenylalanine, and tyrosine hydroxylase as regulators of melanogenesis

A recent theory proposes that tetrahydropteridines, phenylalanine, and tyrosine hydroxylase participate in the regulation of the initial steps of melanogenesis in the human skin (673). Thus in human epidermis synthesis of melanin is dependent on the *in situ* L-tyrosine production by phenylalanine hydroxylase (PH) (EC 1.14.16.1), which in turn requires the presence of cofactor (6*R*)-L-erythro-5,6,7,8-tetrahydrobiopterin (6BH₄). Both PH and the full system for the *de novo* synthesis and recycling of 6BH₄ are expressed in human melanocytes (661, 670, 676). Transport of L-tyrosine by keratinocytes (they surround melanocytes in the epidermis) is very low, making its relative availability to melanin through this pathway also low (673). Conversely, *in vitro* experiments (673) had demonstrated active transport of L-phenylalanine and *in situ* turnover to L-tyrosine, thus contributing two-thirds of the substrate needed for melanogenesis, whereas only one-third originates from L-tyrosine transport. These findings are consistent with L-tyrosine control of synthesis/assembly and activity of melanogenic apparatus in amelanotic Bomirski hamster melanoma cells and the lack of such effect in Cloudman S-91 melanoma cells (735). The latter express PH activity making them independent of external tyrosine supply (77). This concept is also consistent with the findings in human epidermis of proportionality between 6BH₄ levels, PH activity, and skin phototypes. PH activity and 6BH₄ are lowest in skin type I and highest in type VI skin (661, 670). Production of the cofactor in concentrations that would yield L-DOPA needed for activation of Met-tyrosinase could alternately be met by local tyrosine hydroxylase, since this is ex-

pressed in both human keratinocytes and melanocytes (457). Indirect support for this concept comes from the documentation in human skin of tryptophan hydroxylase expression (749, 752, 757); this enzyme, similar to PH and TPH, requires 6BH₄ as its cofactor.

Lastly, a central role for 6BH₄ in the initial regulation of melanogenesis is emerging from studies in vitiligo patients who have a blockade in the recycling of that cofactor originating from the deactivation of the rate-limiting recycling enzyme 4α-carbinolamine dehydratase (DH) (EC 4.2.1.96) by hydrogen peroxide (H₂O₂) (667, 671, 673, 674). As a consequence, the accumulated 7BH₄ inhibits PH reducing the supply of L-tyrosine, while 6BH₄ can act as allosteric inhibitor of tyrosinase (904). Conversely, photo-oxidation of 6BH₄ by UV-B to 7,8-dihydroxanthopterin or perhaps, its complexing with α-MSH lead to activation of tyrosinase allowing melanogenesis to proceed (490, 579, 666). Yet to be explained is coincidence of melanogenesis induction and induction of thioredoxin reductase in black and brown guinea pigs and in murine melanoma cells (664). Epidermal thioredoxin reductase activities also increase linearly with increase in skin phototypes (from type I to VI) (670).

5. Other melanogenesis-related proteins

Additional enzymatic regulators of melanogenesis include peroxidase (EC 1.11.1.7), PMEL 17/HMB45/gp100/SILV protein(s), and catechol-*O*-methyltransferase (COMT) (EC 2.1.1.6) (29, 387, 530, 531, 597, 598, 765). Peroxidase catalyzes the oxidation of DHI and DHICA (597, 598). The enzyme responsible for *O*-methylation of DOPA and its dihydroxyindolic intermediates, COMT, is present as soluble and membrane-bound isoforms (765). Its proposed role is inactivation of toxic intermediates of melanogenesis, and thus it may regulate the velocity of the early steps of melanogenesis (765). Indolic melanogens can be conjugated with glucuronic and sulfuric acid to form indolic sulfates and glucuronate complexes (597, 598).

The human gene *PMEL 17/HMB45/gp100/SILV* maps to chromosome 12q12-q13 and is homologous to the silver locus in mice (387, 388). The gene comprises 11 exons and 10 introns spanning 9.1 kb; processing of the transcribed mRNA generates at least two alternatively spliced isoforms coding for PMEL17 and GP100 proteins (515, 773). PMEL17 is a 668-amino acid protein with a potential signal peptide and a single transmembrane domain near the COOH terminus (515, 773). GP100 is a 661-amino acid protein with an ~100 kDa molecular mass that differs from PMEL17 by the presence of one substitution (P274L), and by the deletion of the heptapeptide (588VGILLT594) located before the transmembrane domain. Both glycoproteins are recognized by HMB45 monoclonal antibodies, contain cysteine, and histidine-

rich regions and are associated with the melanosomal membrane and matrix. They share the ExxPLL motif (proposed as melanosomal targeting signal) and cysteine and histidine-rich regions (reviewed in Refs. 515, 773). PMEL17 catalyzes the polymerization of DHICA to melanin (109). In addition, PMEL17/GP100 may act in melanosomes as scaffold for deposition of melanin, stabilizing melanin intermediates (262). GP100 and PMEL17 transcripts are expressed in many tissues, but expression of the protein is restricted to normal and malignant melanocytes, indicating tight translational regulation (515, 773).

Other possible regulators of melanogenesis that remain to be characterized and cloned include DHI inhibitory factor, which decreases the rate of DHI transformation to melanin, and stablin which prevents autoxidation of DHICA to melanin (515, 561, 573). Among the enzymes indirectly affecting melanogenesis are glutathione reductase and glutathione peroxidase that regulate the levels of reduced and oxidized glutathione (515, 597, 598). Catalase regulates H₂O₂ removal; H₂O₂ is a potent inhibitor of tyrosinase (672).

Macrophage migration inhibitory factor (MIF) is an additional modifier of melanogenesis, which expresses D-dopachrome tautomerase activity (81, 262, 467, 638). MIF is widely expressed in different tissues and transforms both D-dopachrome, DOPaminechrome, or its derivatives to indole compounds that serve as precursors to melanin or neuromelanin (262). According to Sonesson et al. (775), there may be two enzymes expressing dopachrome tautomerase activity, one is D-dopachrome tautomerase (DDT) that transforms D-dopachrome to DHI (523) and the other is MIF itself transforming D-dopachrome to DHICA. Although it is still undetermined whether these activities are expressed by separate proteins or the same protein, it is already recognized that in addition to its cytokine function, MIF can also act as cytoprotector of immunomodulator (81, 262, 638).

C. Extrapigmentary Functions of Melanogenesis-Related Proteins

Tyrosinase and gp100 are MRPs that represent recent diagnostic markers and therapeutic additions to the management of melanoma (reviewed in Refs. 97, 716, 718). Tyrosinase, TYRP-1, TYRP-2, GP100, and melanosome specific MART 1 are classified as major histocompatibility complex (MHC) class I-restricted tumor antigens (or MHC-I and -II in case of tyrosinase), thus being potentially useful in melanoma diagnosis therapy (reviewed in Refs. 97, 716, 718, 869). Therapeutic applications would involve the generation of specific peptides to activate a T-lymphocyte response against melanoma cells. Such a T-cell immune response could however be highly variable because MRP-derived peptides can be recognized by T cells in

association with multiple haplotypes including HLA-A2, HLA-A24, HLA-B44, HLA-A1, HLA-DR4, and HLA-DR15 (651, 718, 760, 766, 869). MRP antigens may also represent immune targets for the melanocyte destruction in vitiligo (255, 869), or for the initiation of alopecia areata (558).

MRPs also have indirect extrapigmentary functions related to their catalytic activity with production of L-DOPA and other intermediates of melanogenesis (736, 739, 743, 746). Thus L-DOPA and products of its oxidation inhibit the immune system (729, 743), whereas inhibition of T-cell response against melanin-producing fungi is dependent on melanogenesis (302, 868). Melanin precursors have genotoxic and mutagenic effects, which may be amplified by the free radicals and reactive oxygen species generated during melanogenesis. This mutagenic environment in melanoma cells may lead to genetic instability and appearance of new, more aggressive cell populations resistant to therapy (743). Melanogenesis and its intermediates can switch cell metabolism from aerobic to anaerobic glycolysis, stimulate pentose phosphate pathway, and/or inhibit glycoprotein phosphorylation (683, 684, 727). Through these mechanisms melanogenically active melanosomes may affect functions and responses of keratinocytes or macrophages (746).

Because of the sharing of L-DOPA precursor, melanogenesis and catecholaminogenesis may be subject to potential interactions. For example, the presence of dopamine in TH null mice fetuses suggests an alternative route to dopamine synthesis not mediated by TH. In this regard, the presence of tyrosinase in pigmented TH null mice has been associated with higher tissue levels of catecholamines compared with albino TH null mice (621). This potential TH-independent source of dopamine is consistent with the observation of age-related decreases in dopamine production in the periphery during the early postnatal period in TH-null pigmented mice (161). Tyrosinase-dependent dopamine production could also occur via additional decarboxylase activities to convert L-dopa to dopamine. Reportedly the incidence of Parkinson's disease is lower in humans with heavier pigmentation (630). Also, sensitivity to the dopamine agonist apomorphine is greater in mice with reduced, or no tyrosinase activity (e.g., albino mice) (630, 799). Tyrosinase has indeed been detected in the brain (826), and the infusion of tyrosinase into the striatum may increase striatal dopamine levels (16).

TYRP-2/DCT is expressed in migrating melanoblasts and in the telencephalon of mouse embryos, where the tyrosinase and TYRP-1 genes are not normally expressed (785). DCT mRNA is also expressed in glioblastoma multiforme (797) and in retinoblastomas (846). It is therefore conceivable that the DCT expressed in these tissues may be responsible for functions other than melanin production, such as detoxification of metabolites derived from

DOPA (785). This would be consistent with a postulated role for TYRP2 in melanocyte survival (262).

III. MECHANISMS OF REGULATION OF MELANOGENESIS

A. Transcriptional Regulation

The gene for tyrosinase contains at least one major and three minor transcription starting sites (515); the promoter region contains TATA and CAAT boxes, several potential microphthalmia-associated transcription factor (MITF) binding sites including M-boxes, E-boxes, and tyrosinase distal element (TDE), five AP-1 and two AP-2 binding sites for the phorbol ester-inducible enhancer-binding protein AP-1 (activator protein-1), glucocorticoid responsive elements (GRE), UV responsive elements (URE), Oct-1 boxes (octamer element binding POU domain transcription factors), thyroid and retinoic acid-like responsive elements (TRE and RER), tyrosinase element-1 (TE-1), high mobility group protein (HMG-1) binding element, SP1 element, and two DNase I hypersensitive sites (HS-sites) embedded within a scaffold/matrix attachment region (S/MAR) (47, 167, 197–199, 358, 387, 390, 489, 703, 704). Of interest is the reported absence of exact sequence of cAMP responsive element (CRE) in the promoter region of human and mouse tyrosinase. However, in humans the first HS binding site (HS1) contained a palindromic sequence resembling the binding motif to both CREB and AP-1. A palindromic sequence resembling binding motifs for CREB was also identified in mice, but competition and immunoprecipitation studies showed that it did not bind CREB (197). Most recently, it was reported that the human tyrosinase promoter contains the hepatocyte nuclear factor (HNF-1) consensus binding sequence, which is activated by dimerization of the cofactor of hepatocyte nuclear factor-1/HNF-1 (DcoH/HNF-1) (663).

The TYRP1 gene contains several potential alternate transcription initiation sites with promoter region structurally different from tyrosinase, e.g., unlike tyrosinase it does not contain TATA or CCAAT boxes (48, 72, 329). The 5'-upstream region of TYRP1 contains several positive and negative regulatory elements including the M- and E-boxes, Oct-1, and two melanocyte specific elements in mouse but not humans (MSEu and MSEi) and lacks the CRE sequence (47–49, 72, 196, 329, 515, 700, 703). The promoter region of TYRP2 contains in addition to M- and E-boxes, CRE-like sequences, AP-2, interleukin-1-responsive elements of the interleukin-6 gene (NF-IL6) and DOPA tautomerase distal enhancer 1 (DDE1) (13, 47, 515, 921). The promoter/enhancer structures of other MRPs such as SILV/PMEL17/GP100 also contain E-box elements. Of interest, the promoter region of mouse and

human MC1R has also been shown to contain an E-box element (21).

Most significant is the presence of motifs such as M-boxes, E-boxes, TDE, TPE, in the promoter regions of MRPs, that constitute binding sites (with a core CANNTG motif) for a large family of transcription factors sharing a basic helix-loop-helix structure required for DNA binding and dimerization. The important representative of the basic helix-loop-helix-leucine zipper (b-HLH-ZIP) is MITF that plays a fundamental role in the transcriptional regulation of melanogenesis (see sect. VII). Its binding to promoter regions of MRPs is necessary for the melanogenic activity of the melanocytes and the development of melanocytes lineage (see below). Although other b-HLH-ZIP proteins such as TFE3 or TFEB have been shown to play a role in regulation of melanogenesis in cell culture (860), there is no genetic evidence that various members of this family including USF, Myc and Max, and various TFE3 family members are involved in the developmental regulation of pigmentation (99). A more complex role in transcriptional regulation (positive and negative) of melanogenesis-related genes is played by the member of the class III POU binding protein Brn-2/N-Oct3 (160, 823). The negative transcriptional regulation of TRP1 is mediated by brachyury-related transcription factor (TBX2), while the opposite action is executed by PAX3 (protein identical to MSF) through binding to MSE (98, 196). The positive involvement of the latter is expressed in the phenotypic pigmentation of Waardenburg syndrome types 1 and 3 in which PAX3 is mutated (816, 817). In murine melanoma cells, downregulation of PAX3 results in melanogenesis, with the shut-off through the probable involvement of Mitf promoter silencing (343). Thus regulation of MRP gene expression is mediated by positive and negative transcriptional regulators of which MITF is essential. It must be noted that regulation of gene expression at the mRNA level represents only the initial step; the final regulation of melanin synthesis appears to be predominantly controlled by posttranslational mechanisms.

B. Intracellular Signal Transduction Pathways

Figure 7 shows the major signal transduction pathways involved in the positive regulation of melanogenesis with cAMP as the critical factor. The fundamental role of cAMP in the regulation of melanogenesis and melanocytes proliferation was initially recognized in mouse melanoma cells (415, 568, 569, 899–901). Subsequent studies confirmed stimulation of melanogenesis by factors raising intracellular concentration of cAMP through receptor-mediated activation of adenylate cyclase, inhibition of phosphodiesterase, or transmembrane delivery of modified cAMP into the cell (92, 515).

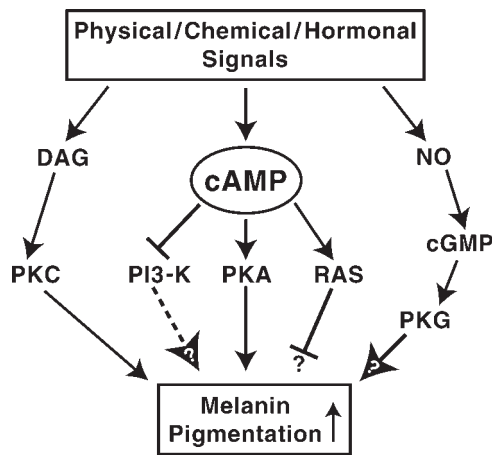

FIG. 7. Intracellular signal transduction pathways regulating melanogenesis. ?, Detailed involvement of this pathway needs further study; DAG, diacylglycerol; PKC, protein kinase C; PI3-K, phosphatidylinositol 3-kinase; PKA, protein kinase A; NO, nitric oxide; PKG, protein kinase G.

The mechanism of cAMP regulation of melanogenesis involves the activation of protein kinase A (PKA), which then phosphorylates enzymes, ion channels, and several regulatory proteins. Involvement of PKA in the posttranslational regulation of melanogenesis was clearly demonstrated by Pawelek and co-workers (373, 568, 569, 899, 900) and was confirmed by others (190, 264, 515, 552). In addition, PH and TH hydroxylation phenylalanine to tyrosine and tyrosine to DOPA, respectively, are controlled by the PKA-dependent phosphorylation of regulatory serine residues (790). Regulation of transcriptional activity by activated PKA involves phosphorylation of cAMP responsive element binding protein (CREB) and CREB binding protein (CBP). Phosphorylated CREB interacts with CBP to activate the (566) expression of MITF throughout the CRE in the promoter region of the gene (648, 701, 889). MITF in turn regulates transcription of genes coding MRPs through interactions with M- and E-boxes present in the promoter regions of tyrosinase, TYRP1, and TYRP2. Because CRE is absent from the promoter of tyrosinase and TYRP1 genes, the transcriptional control of melanogenesis by cAMP is coordinated predominantly by MITF (47, 48, 423, 648, 701, 889). However, transcription of TYRP2 can potentially be activated through direct activation of CRE by CREB (49).

cAMP also modifies other pathways controlling melanocyte differentiation and proliferation, for example, the phosphatidylinositol (PI) 3-kinase pathway with its downstream regulatory element p70S6 kinase (92, 94, 240, 241). Inhibition of this pathway stimulates melanogenesis, and the pathway can be partially inhibited by cAMP (92–94). cAMP may also regulate dendritogenesis and possibly melanogenesis through activation of the Rho family of

small GTP-binding proteins (92, 93). Of interest, some authors have proposed that cAMP can also inhibit melanogenesis through PKA-independent p21Ras activation (92). Ras would activate B-raf kinase and consequently mitogen-activated protein (MAP) kinases ERK1 and ERK2. MAP kinases phosphorylate MITF leading to its ubiquitination and degradation, thus removing a major transcriptional regulator of MRP genes expression (92, 168, 340). In addition, activation of ras oncogene inhibits melanogenesis in normal and malignant melanocytes (168, 245, 844).

Another signal transduction pathway important in the regulation of melanogenesis is represented by protein kinase C (PKC) (213, 217, 551, 552, 555). Thus diacylglycerol (endogenous activator of PKC) can stimulate melanin synthesis both in cell culture and in vivo (10, 217), while melanogenesis is blocked by PKC inhibitors or cellular depletion of PKC (48, 551, 552). Accordingly, 12-*O*-tetradecanoylphorbol 13-acetate (TPA) would have an initial activatory effect on melanin synthesis (activation of PKC) and a long-term inhibitory effect from PKC depletion in cells after the TPA treatment. The major PKC isoform involved in the regulation of melanogenesis is PKC- β (551), which can also activate tyrosinase through phosphorylation of serine residues in its cytoplasmic domain (552). In addition, the association of activated PKC- β with melanosomes through interaction with a membrane receptor for the activated PKC- β (RACK-1) has been reported. It is possible that cross-talk between PKC and PKA pathways could amplify their melanogenic effect through cAMP-dependent stimulation of genes transcription (including PKC) (551). Other PKC isoforms potentially involved in the regulation of melanocyte differentiation and proliferation are α , δ , ϵ , and ζ (551, 552).

Additional pathways that have been involved in the positive regulation of melanogenesis include those activated by nitric oxide (NO) and cGMP (628) as well as thymidine dimers (165, 166, 212). Thus the melanogenic effect of UV radiation could be connected with local production of NO and activation of guanylate cyclase with subsequent accumulation of cGMP in the melanocytes; in fact, inhibition of NO and cGMP production blocked the melanogenic effect of UV radiation (628). Thymidine dimers and small single-stranded DNA fragments (ssDNA) can also stimulate melanogenesis in cell culture and in vivo. This effect is dependent on the sequence and length of the oligonucleotides, regulated at both transcription and translation of MRPs levels, and involved amplification of the melanogenic effect of α -MSH (165, 166, 212, 552). These pigmentary effects of small oligonucleotides could follow a pathway functionally similar to the SOS response system of bacteria (165).

C. Dual Function of L-Tyrosine and L-DOPA: Reaction Substrates and Bioregulators

1. Overview

L-Tyrosine and L-DOPA have long been known to be substrates of the melanogenic pathway that determines their metabolic fate; however, they also possess a recently elucidated and important role as positive regulators of melanogenesis (reviewed in Ref. 739). Thus, in hamster amelanotic and melanotic melanoma cells, both L-tyrosine and L-DOPA stimulate, induce, or regulate various elements of the melanogenic apparatus by overlapping though distinct mechanisms (720, 721, 732–735). When Bomirski hamster melanoma cells were cultured in media relatively low in tyrosine (10 μM), L-tyrosine supplements produced concomitant increases in melanin synthesis and tyrosinase activity (rate-limiting step in the melanogenic pathway) (735). Nevertheless, in parallel experiments performed with mouse Cloudman S91 melanoma cells L-tyrosine, while also increasing melanin pigmentation, had no effect or even decreased tyrosinase activity (735). Thus, depending on the experimental model, L-tyrosine can act as a stimulator or modifier of melanogenic apparatus or, only as substrate increasing melanin content without affecting the pathway enzymes. Further studies in human melanocytes system have shown that L-tyrosine and L-DOPA are necessary for the proper folding of tyrosinase in the ER, protecting it from entering the degradation pathway. L-Tyrosine and L-DOPA enhanced tyrosinase exiting from the ER, its carbohydrate modifications in the Golgi apparatus, and its transport into melanosomes increasing melanin pigmentation (244, 246, 247, 249).

2. L-Tyrosine and L-DOPA as positive regulators of subcellular apparatus of melanogenesis

L-Tyrosine stimulates tyrosinase activity in a dose-dependent manner in three different lines of hamster melanoma, with the slope being determined by the melanogenic potential of the cell line (Fig. 8) (735). Thus, in melanotic lines, tyrosinase activity reaches its peak at optimal media tyrosine concentration (200 or 400 μM), and decreases at pharmacological concentrations (400 or 600 μM). The decrease is not observed in amelanotic cells. Stimulation of tyrosinase activity by L-tyrosine is also seen in human malignant melanocytes (472, 895), normal epidermal melanocytes (603), and C57BL/6 mouse melanocytes with p locus mutation (635). L-DOPA shows a similar dose-dependent effect on tyrosinase with peak of tyrosinase stimulation at 25–50 μM , and decreases in enzyme activity at higher concentrations (100 or 200 μM) (721, 735). In Cloudman S91 melanoma cells, prestabilization of L-DOPA by the addition of phosphate (to produce phospho-L-DOPA) was required to express the dose-dependent stimulatory effect on tyrosinase activity and melanin pigmentation through amplification of the MSH

receptor system (475). Thus, in Cloudman melanoma cells, L-DOPA itself does not affect melanogenesis (475), although at very low concentrations it does stimulate cell proliferation (560). In *in vivo* experiments, phosphorylated L-DOPA also stimulates skin melanin pigmentation (7), acting synergistically with UVB (560). Similarly, topical application of L-tyrosine in Skh:HR2 mice amplified the cutaneous melanogenic response to UVB (870). This is consistent with L-tyrosine acting as an inducer of melanogenesis in amphibian embryonic cells (403, 438). A stimulatory effect of L-tyrosine on differentiation of cultured frog melanophores has also been reported (189).

In hamster amelanotic cells L-tyrosine and L-DOPA induced rapid increases of tyrosinase activity and also in melanosomes and melanin synthesis (Fig. 9); the effect was specific since under the same conditions the enantiomers (D-isomers) or related aromatic amino acids had little or no effect, and it also required protein synthesis (735). It was positively excluded that these actions would be related to transformation of L-tyrosine and L-DOPA to catecholamines, or to activation of adrenergic or dopaminergic receptors (293). L-Tyrosine and L-DOPA acted through related but distinct mechanisms (720, 721, 732–734, 748), with L-tyrosine inducing both melanosomes synthesis and tyrosinase translocation from the *trans*-Golgi reticulum (TGR) to melanosomes, while L-DOPA primarily increased tyrosinase leading to its accumulation in the TGR. Their effects on tyrosinase gene transcription differ, e.g., L-tyrosine has no effect on tyrosinase mRNA by, while L-DOPA produces an initial increase in tyrosinase mRNA followed by a decrease below control levels (720, 721). The latter effect could be due to tyrosinase-mediated oxidation of L-DOPA generating toxic intermediates of melanogenesis, which would in turn shut-off tyrosinase gene expression as protective mechanism against self-destruction (721).

Phenylthiourea (PTU) is a nontoxic inhibitor of melanogenesis that inhibits stimulation of tyrosinase by L-tyrosine, without affecting L-DOPA stimulation in hamster amelanotic melanoma cells (734). However, L-tyrosine does stimulate premelanosome synthesis predominantly at stage II of development in PTU-treated cells. In the same system, melanogenesis induced by L-DOPA in the absence of L-tyrosine was rate limited by inadequate melanosome synthesis (735, 734). Since the formation of melanosomes precedes the induction of melanogenesis, L-tyrosine may have a crucial role in the induction of the subcellular apparatus of melanogenesis, e.g., enhancing both melanosome synthesis and translocation of tyrosinase from the TGR (Fig. 9) (735, 734). In mouse melanocytes with p mutation, L-tyrosine stimulates melanosome production, maturation, and tyrosinase redistribution (280, 635), while in human normal and malignant melanocytes L-tyrosine enhances tyrosinase exit from the ER, its modifications in Golgi, and its transport to melanosomes,

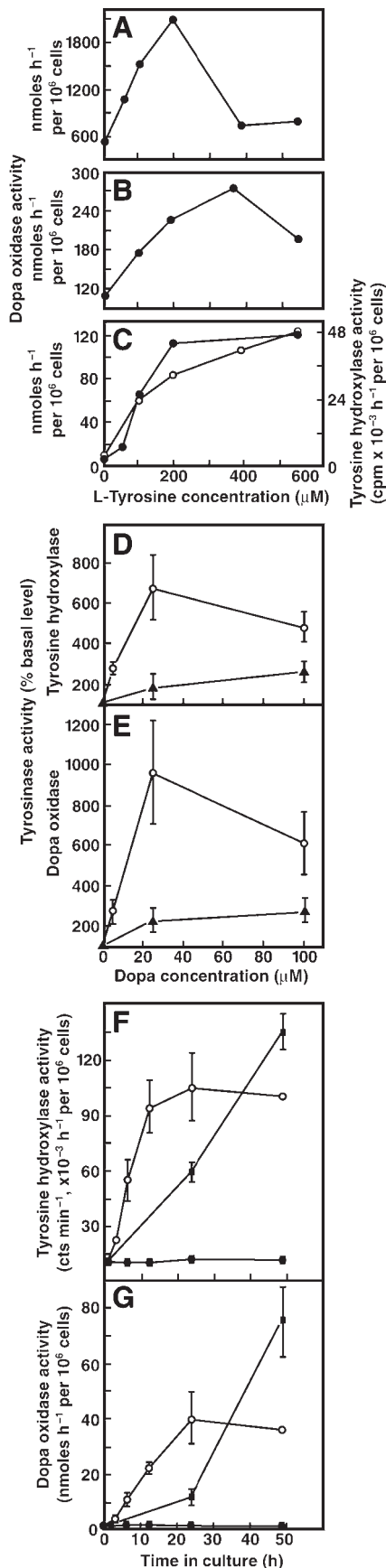

resulting in increased melanin pigmentation (247). Therefore, L-tyrosine may act as subcellular initiator of melanogenesis, while L-DOPA produced within melanosome would act at a later stage increasing further tyrosinase concentration (736). L-DOPA would then represent a second messenger to tyrosine in the *in vivo* regulation of tyrosinase synthesis and processing (734). Furthermore, tyrosinase, with its tyrosine hydroxylase (producing L-DOPA) and DOPA oxidase activities, would act as a regulatory protein for the subcellular apparatus of melanogenesis, of which it is itself an integral component (734), participating in the regulation of melanocyte metabolism during active melanogenesis (reviewed in Refs. 736, 739). Acting in concert, L-tyrosine, L-DOPA, and tyrosinase regulate the melanogenic apparatus and the overall physiology of the melanocyte in a stochastic fashion. The latter would depend on changes in the phosphorylation/dephosphorylation pattern (727).

3. L-Tyrosine promelanogenic effect and *p* locus

Mutations in pink-eyed dilution gene (*P*) result in a common form of human albinism, OCA2, and in the pink-eyed dilution phenotype in mice (72, 524, 708, 792). These mutations are expressed as decreased pigmentation of hair, skin, and eyes. The *p* gene product is a transmembrane protein (204, 620) thought to have among various functions (see previous sections) that of melanosomal proton pump (78, 601). Patients with mutations at the *p* locus have defective processing of tyrosinase and tyrosinase-related proteins with intracellular misrouting, proteolysis, and/or secretion to the extracellular environment (249, 451, 840). These abnormalities result in decreased tyrosinase activity and MRP protein concentration with hypopigmentation. Melanosome number and differentiation levels are decreased, and melanosomal ultrastructure is also abnormal (280, 539). Accordingly, *p* protein acts directly or indirectly as coordinator of the MRPs routing to melanosomes.

The pigmentary deficit of the OCA2 can be overcome by L-tyrosine, which stimulates melanin synthesis even in amelanotic melanocytes (reviewed in Ref. 539). In fact, mouse melanocytes containing mutations at the *p* locus show partial correction of the defect by properly targeting tyrosinase and TyrP1 to melanosomes upon increasing the concentration of L-tyrosine (280, 451, 635), similar to its effects in hamster amelanotic cells (see above). In the latter model, tyrosine treatment increased the number of

FIG. 8. L-Tyrosine and L-DOPA regulate tyrosinase activity in cultured melanoma cells. The cells were cultured in Ham's F-10 medium (low in tyrosine) for 24 h (*D* and *E*), 48 h (*A*–*C*), or as noted on the *x*-axis; media concentrations of L-tyrosine and L-DOPA are as presented for *A*–*E*. *F* and *G*: ○, 200 μM L-tyrosine; ■, 25 μM L-DOPA; ●, control. At indicated time points the cells were harvested and lysed, and tyrosinase activity was measured. [Modified from Slominski et al. (735).]

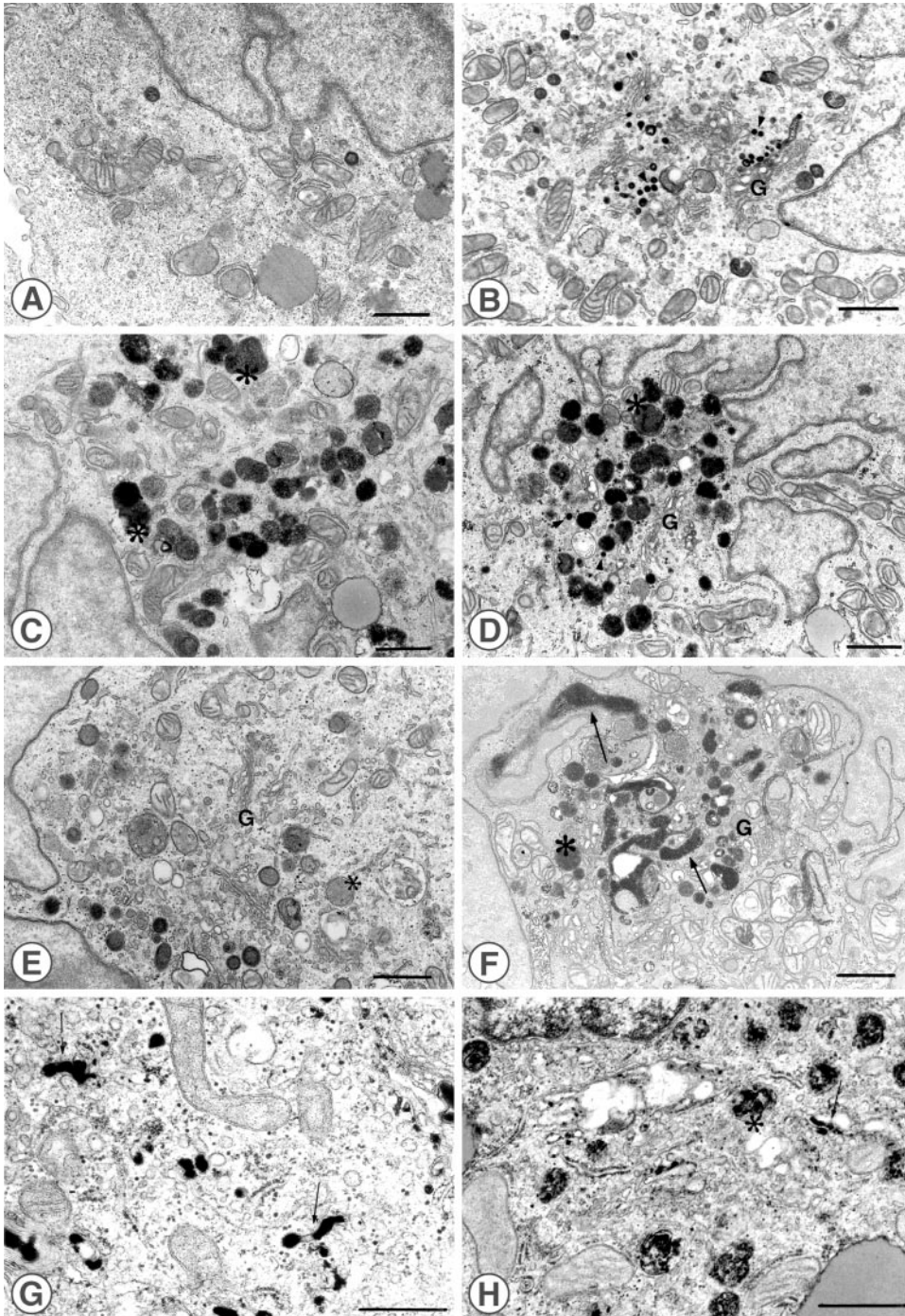

FIG. 9. Effect of L-tyrosine and L-DOPA on melanosome synthesis and proteins routing. Cells were cultured for 2 days in the absence (A, B, G) or presence of L-tyrosine (C, D, H) or L-DOPA (E, F), then fixed for transmission electron microscopy (A, C, E) or processed for ultrastructural dopa-oxidase (B, D, F) or acid phosphatase (G, H) histochemistry. G, Golgi apparatus; asterisks, melanosome; arrows, products of DOPA reaction in TGN (F) or acid phosphatase reaction in endoplasmic reticulum (G and H). [Modified from Slominski et al. (735).]

melanosomes at later stages of maturation as well as activity and concentration of tyrosinase and TyrP1 with their rerouting to melanosomes (280, 451, 635). This up-regulation of melanogenesis appears to be mediated at the posttranscriptional level (635, 720). Studies in cultured melanoblasts and melanocytes from C57BL/10 mice show that L-tyrosine also increases intracellular concentration of *c-kit*, TyrP1, and TyrP2 protein in both nonmutant (PP) and mutant (pp) cells (280). L-Tyrosine, nevertheless, in-

hibits proliferation of PP melanocytes while stimulating proliferation of pp melanocytes.

4. L-Tyrosine and L-DOPA regulate MSH receptor expression

L-Tyrosine or phosphorylated isomers of L-DOPA stimulate MSH receptor activity in hamster and mouse melanoma cells (475, 560, 732, 748). In normal human

epidermal melanocytes, tyrosine levels have been shown to regulate the melanogenic response to α -MSH (681). In amphibian melanoblasts, L-tyrosine acts synergistically with MSH in stimulation of melanogenesis (188). Phosphorylated isomers of L-DOPA increase MSH receptor expression in mouse melanoma cells and stimulate the melanogenic response to β -MSH peptide (475). Similarly, in hamster melanoma cells, L-tyrosine but not L-DOPA stimulates cell surface MSH receptor expression, enhances level of tyrosinase stimulation by MSH, and reduces positive cooperativity among cell surface MSH receptors (732, 748). The effect appears to be specific for the MSH receptor, because it does not affect expression of the unrelated insulin receptor (730). Stimulation of MSH receptors does require prolonged exposure to the factors tested (475, 732, 748), and the lack of effect of L-DOPA is most likely due to its oxidation. In hamster amelanotic melanoma, stimulation of MSH receptor activity is maximal when L-tyrosine has induced the full melanogenic potential of the cells (748). Interestingly, in other melanoma models, stimulation of melanogenesis increases expression of MSH receptors (726). L-Tyrosine does not change MC1 receptor mRNA concentrations in hamster melanoma (Slominski, unpublished data), while in human melanoma induction of melanogenesis by DMEM increases MC1 mRNA concentration (726).

5. L-Tyrosine and L-DOPA as "hormonelike bioregulators"

The overall actions of L-tyrosine and L-DOPA in the pigmentary system strongly support an additional role for these melanin precursors as hormonelike bioregulators, and thus melanocytes would regulate L-tyrosine and L-DOPA activity affecting both production and metabolic consumption (736). Such roles require support from the identification and characterization of receptors for those amino acids (739), since their dose- and time-dependent actions and stereoselectivity are consistent with receptor-mediated mechanisms. Indeed, cell surface and nuclear binding sites for L-tyrosine or L-DOPA have been detected, and the binding was saturable, specific, and reversible (715, 754). Cross-linking experiments also identified cell surface proteins binding specifically L-tyrosine (5 proteins of 55, 45, 40, 30, and <20 kDa) and L-DOPA (4 proteins of 55, 30, 25, and <20 kDa) (715, 739, 754). These proteins were neither adrenergic nor dopaminergic receptors or amino acids carriers. Potential candidates include p protein, alternatively spliced products of tyrosinase or tyrosinase-related proteins, blurring the classical distinction between specific transporter, enzyme, and receptor. Thus, depending on L-tyrosine and L-DOPA concentrations, membrane-bound binding proteins may allow formation of melanosomes and/or delivery of elements for melanogenesis via intracellular or endocytic pathways (739). Be-

cause melanogenesis-related proteins have the cysteine-rich sequences characteristic of peptide hormones, they may regulate melanocyte function through binding to proteins, acting at the translational or transcriptional levels (739). Identification of cytosolic and nuclear binding sites for L-DOPA but not L-tyrosine suggests the potential for an additional nuclear receptor for this relatively short-lived molecule, allowing coordination of intracellular functions in an intracrine fashion (739). In lower organisms (uni- or multicellular), there are indications of L-tyrosine and L-DOPA receptor expression; in mammalian systems, L-tyrosine and L-DOPA may act as neurotransmitters (reviewed in Refs. 736, 739). Definitive establishment of the concept will require the testing of primary epidermal and follicular melanocytes for expression of putative L-tyrosine and L-DOPA receptors.

With regard to the metabolic effect of L-DOPA, this consists of *in vitro* inhibition of glycoproteins phosphorylation (727); in isolated cells, L-DOPA stimulates the pentose phosphate pathway (683) and switches the energy metabolism from aerobic to anaerobic glycolysis (682).

D. Summary

Therefore, key elements in the regulation of melanogenesis are represented by tyrosinase and TYRPs. The complexity and precise control of melanogenesis are evident by the presence in the genes of motifs for binding sites of a large family of transcription factors. At the intracellular level, the major regulatory pathway involves the common mediator cAMP, although PKC is also involved. A new turn in the regulatory process has been introduced by cumulative evidence indicating that L-tyrosine and L-DOPA, besides serving as substrates for melanin, are also bioregulatory agents. Evidence obtained with the improvement of OCA2 by tyrosine strongly supports this concept.

IV. HORMONAL STIMULATORS OF MELANOGENESIS AND THEIR RECEPTORS

A. G Protein-Coupled Receptors and Ligands

1. Melanocortins, ACTH, and melanocortin receptors

A) OVERVIEW OF MELANOCORTINS PHENOTYPIC EFFECTS. *I*) *Melanogenic effect in vivo*. The fundamental role of melanocortins (MSH) and adrenocorticotropins in the regulation of melanogenesis was established during the last century (157, 242, 412, 514, 559, 561, 569), culminating in the definition of their regulatory role with purification and full sequencing of the α - and β -MSH peptides (412). Structurally, MSH peptides (that include α -MSH, β -MSH, and γ -MSH peptides) have in common with ACTH the amino

acid sequence -Tyr-x-Met-x-His-Phe-Arg-Trp- containing the tetrapeptide His-Phe-Arg-Trp critical for melanotropic activity (157, 242). There is consensus that the proopiomelanocortin (POMC) peptides with significant melanogenic activity are ACTH, α -MSH, and β -MSH (see below).

Initial experiments in amphibians determined that α - and β -MSH induced darkening of the skin (reviewed in Refs. 242, 412). In mammalian systems, such as rodents, MSH peptides do stimulate both melanogenesis and the switching of the pheo- to the eumelanogenic pathway (127, 157, 209, 225, 242, 515, 813). In several strains of adult mice as well as hamsters, α -MSH specifically stimulates follicular melanogenesis, depending on genotype and hair cycle (89, 90, 127, 209, 225, 242, 418, 433, 515). For example, *e/e* mice (recessive for the E locus encoding MC1 receptor) are unresponsive to MSH pigmentary action (813), although α -MSH does stimulate tyrosinase activity at the transcriptional, translational, or posttranslational level depending on the phase of hair cycle (89, 90, 157, 209, 242, 515). This is consistent with hair cycle restricted expression of melanogenesis-related genes, protein concentration, and enzymatic activity (737, 741, 745). β -MSH also stimulates tyrosinase activity, as observed in skin of newborn Syrian golden hamsters as well as black and brown mice (588) and has actual melanogenic activity in adult guinea pigs and hairless mice (63, 64). Overall, the promelanogenic effect of MSH peptides has been documented in a number of species (127, 157, 209, 242, 515).

In humans, the systemic administration of α -MSH, β -MSH, or ACTH stimulates skin pigmentation, predominantly in sun-exposed areas (414, 419). Clinical observations have shown that the pathologically increased levels of plasma ACTH in Addison disease, or the excessive ACTH production by tumors (Nelson syndrome), are accompanied with hyperpigmentation and skin atrophy (reviewed in Refs. 181, 515, 759). Prolonged administration of synthetic ACTH in humans also induces skin atrophy and hyperpigmentation as well as hypertrichosis (reviewed in Refs. 181, 762) and elevated serum concentrations of α -MSH with skin pigmentation (576). In most patients with ACTH/ α -MSH excess hyperpigmentation is generalized, but most prominent in sun-exposed areas. In contrast, patients with pituitary POMC gene mutations leading to defective production of the POMC protein have red hair pigmentation in addition to early onset of obesity and adrenal insufficiency (reviewed in Ref. 762). Finally, MC1 receptor polymorphism has been linked with skin and hair pigmentation, and mutations reducing MC1 receptor activity lead to lighter skin pigmentation and red hair phenotype (660, 792).

II) Melanogenic effects in cell cultures. Melanogenesis is a highly regulated process modified by postranslational, translational, or transcriptional mechanisms (157, 242, 487, 515, 559). In melanoma cells both α - and β -MSH

stimulate melanogenesis activating tyrosinase as well as post-dopa oxidase steps (157, 242, 515, 561, 573). Studies in rodent malignant and normal melanocytes have uncovered the role of MSH receptors in the regulation of the melanocyte functions, acting via cAMP-dependent pathways (157, 242, 277, 412, 487, 515, 559, 561, 562, 564, 565, 573, 570, 572, 574, 733). In rodent malignant melanocytes, α -MSH and β -MSH are more potent than ACTH in stimulation of melanogenesis (157, 487, 559). The effect of MSH on cell proliferation is variable and depends on cellular genotype (157, 303, 487, 515, 559, 562, 564, 566, 567, 570, 707); for example, MSH inhibits proliferation in amelanotic cells, indicating that this effect is unrelated to production of toxic intermediates of melanogenesis (487, 559, 733). In addition, MSH stimulates dendrite production through a pathway independent from that regulating melanogenesis, although still cAMP mediated (515, 733). Similar MSH effects, e.g., stimulation of melanogenesis, dendrite formation, and stimulation of cell proliferation are also seen in normal cultured mouse melanocytes (242, 277, 515).

Affinity of ACTH or MSH peptides for MC1 receptor differs according to the species investigated. For example, cloned rodent MC1 receptor has high affinity for α -MSH, but low for ACTH and β -MSH, and even lower for γ -MSH (127, 515). In cultured rodent cell lines, α - or β -MSH are more potent than ACTH in stimulation of melanogenesis (402). The human MC1 receptor affinity is equally high for α -MSH and ACTH, and lower for β -MSH and γ -MSH. The MC2 receptor exhibits absolute specificity for ACTH. Mutations in the MC1 receptor that produce unresponsiveness of epidermal melanocytes to MSH result in the red hair phenotype (515, 851). In cultured human melanocytes, α -MSH, β -MSH, and ACTH at concentrations in the nanomolar range or lower stimulate melanogenesis, cell proliferation, dendrite formation, and cAMP production (2, 303, 304, 798). In some studies ACTH was more potent than MSH (303, 304), while in others both peptides were equipotent (2, 798). γ -MSH, which stimulates cAMP production, had no significant effect on melanogenesis or proliferation in human melanocytes (798), and low melanogenic activity in murine and hamster malignant melanocytes (723), and in frog and lizard melanophores (157, 242, 515). It is possible selected γ -MSH peptides could still modulate pigmentation indirectly, by modifying the cellular response to other melanotropins. For example, γ 2-MSH potentiates the melanogenic activity of α - or β -MSH, while γ 3-MSH (acting as a partial agonist on MSH receptors) largely inhibited the melanogenic activity of α - or β -MSH (723). α -MSH also stimulates the attachment of human melanocytes to laminin and fibronectin and inhibits TNF- α -stimulated intercellular adhesion molecule-1 (ICAM-1) expression in normal and malignant human melanocytes (reviewed in Ref. 756).

B) MOLECULAR CHARACTERIZATION OF MELANOCORTIN RECEPTORS. Cross-linking experiments identified a membrane-bound MSH receptor of ~45 kDa in a number of melanocytic lines (774), and subsequently, a family of melanocortin (MC) receptors (MC1 to MC5) was cloned (119, 120, 200, 201, 391, 497, 498, 634). They belong to the superfamily of seven transmembrane G protein-coupled receptors, share amino acid sequence homology of 40–60%, and have short intracellular carboxy-terminal and short extracellular amino-terminal domains. MC receptors are coupled to adenylyl cyclase, with possible additional coupling to phospholipase C in the case of MC3 (200, 634). MC receptors have different pharmacological profiles of activation by MSH and ACTH peptides; MC1R is the most important in the regulation of melanogenic activity (498, 624; for review, see Ref. 660).

I) *MC1 receptor or MSH receptor.* Human and mouse MC1R consist of 317 and 315 amino acids, respectively, and share 76% homology in amino acid sequence (120, 498). MC1R has the highest affinity for α -MSH and ACTH, as judged by intracellular cAMP accumulation (200, 201, 498) and in vitro binding assay (120). MC1R mRNA is expressed in melanocytes and melanoma cells and in other human skin cells (762).

The mouse extension (E) locus encodes the MSH receptor (MC1R) (624) that determines the relative amount and distribution of brown/black pigment (eumelanin) and yellow pigment (pheomelanin) through its actions on hair follicle melanocytes (708). The dominant allele increases eumelanin synthesis while the recessive yellow allele (*e*) inhibits eumelanin synthesis by coding for a nonfunctioning MC1 receptor. This results from a frameshift that generates a termination codon immediately after the fourth transmembrane domain, thereby deleting the third intracellular loop essential for the receptor-G protein coupling (624). In contrast, three dominant alleles, the sombre (*E^{so}* and *E^{so-3J}*) and tobacco (*E^{tob}*), result from missense mutations clustered around the second transmembrane region, which produce hyperactive MC1 receptors (624). The sombre alleles produce a fairly uniform black coat, whereas the tobacco allele produces dorsal darkening. Functional analysis reveals that the *E^{so-3J}* receptor is constitutively activated, while the *E^{tob}* receptor remains hormone responsive and produces greater activation of adenylyl cyclase (624). Importantly, agouti protein cannot inhibit eumelanin formation induced by the constitutively active sombre receptor (897, 898).

MC1R gene sequence variants were found in over 80% of individuals with red hair and/or fair skin that tans poorly, but in fewer than 20% of individuals with brown or black hair and, in <4% of those who show a good tanning response (851). Human MC1R variants are present in ~50% of white populations (660). The loss-of-function MC1R mutations largely account for the red hair pheno-

type in humans and are associated with fair skin and decreased ability to tan, with a significant heterozygote effect in individuals without red hair. The Asp84Glu variant of MC1R is associated with melanoma (852), and the loss-of-function MC1R variants may increase the risk for developing melanoma and nonmelanoma skin cancer.

II) *MC2 receptor or ACTH receptor.* Human MC2R consists of 297 amino acids and is 39% identical to human MC1R (498). MC2R has specific affinity for ACTH, and its mRNA is predominantly expressed in the cortex of adrenal gland, especially the zona fasciculata, since MC2R is primarily responsible for glucocorticoid production. MC2R mRNA has nevertheless been detected by RT-PCR in human skin biopsy specimens of compound melanocytic nevus, and in cultured normal and malignant melanocytes (725). MC2R was also detected in skin of the C57BL/6 mouse by Northern blotting, being present at concentrations significantly lower (severalfold) than MC1 and in a pattern independent of hair cycle (169). Because some authors found ACTH more potent than α -MSH in stimulation of melanogenesis in human melanocytes (303, 304, 307), a potential role for MC2R in the regulation of melanocytic activity needs clarification.

III) *MC3–5 receptors.* MC3R responds to α -, β -, γ -MSH, and ACTH with equal potency and efficacy, unlike the MSH and ACTH receptors (201). MC3R is unique because of its potent activation by γ -MSH peptide (634). Mouse MC3R is expressed in brain, placental, and gut tissues but not in melanocytes or melanoma cells nor in the adrenal gland (201); MC3R is involved in the regulation of energy homeostasis (95, 113), but not pigmentation.

MC4R responds equally to both α -MSH and ACTH. MC4R is expressed primarily in the brain and is undetectable in the adrenal cortex, melanocytes, and placenta. Null mutations of the MC4R are associated with hyperphagia, obesity, and accelerated longitudinal growth in mice (308). This obesity syndrome could explain the characteristic features of the agouti obesity syndrome in lethal yellow mice, which results from ectopic expression of agouti protein, namely, the overexpressed agouti protein induces obesity by antagonizing at the MC4R. In contrast to MC3R(–/–) mice, MC4R knockout mice exhibit increased food intake and obesity (354). Mice lacking both MC3R and MC4R become significantly heavier than MC4R(–/–) (113). These results suggest that MC3R and MC4R are involved in the regulation of energy homeostasis through separate mechanisms and do not participate in mammalian pigmentation.

MC5R is preferentially bound by α -MSH and is widely expressed in peripheral tissues. These include skin, adrenal gland, skeletal muscle, bone marrow, spleen, thymus, gonads, uterus, and brain (391), with high expression levels in exocrine tissues such as Harderian, preputial, lacrimal, and sebaceous glands (116). MC5R-deficient

mice exhibit exocrine gland dysfunction, such as severely defective water repulsion and thermoregulation due to decreased production of sebaceous lipids, indicating that the MC5R is required for the correct function of the exocrine glands. MC5R has no effect on melanin pigmentation (116).

C) CELL BIOLOGY AND BIOCHEMISTRY OF MELANOCORTIN RECEPTORS. The phenotypic effects of MSH and ACTH peptides in melanocytes are mediated via interactions with cell surface receptors containing seven transmembrane domains linked to the G_s protein and cAMP-dependent pathways (reviewed in Refs. 128, 157, 515). In addition, activation of PKC by α -MSH may also be involved in stimulation of melanogenesis (85, 554). MSH receptor signal transduction may probably be also coupled to phospholipase C-activated production of inositol trisphosphate (IP_3) and diacylglycerol (DG) with subsequent mobilization of intracellular calcium (85). Studies in different melanoma models have generated conflicting results, e.g., in human melanomas α -MSH stimulates IP_3 production (796), while in hamster melanoma the MSH signal transduction and subsequent phenotypic effect are linked to cAMP without any evidence of IP_3 production (733). Pharmacological studies with cloned MC receptors have shown that signal transduction (including MC1) is coupled exclusively to activation of adenylyl cyclase (127, 515). In one case, modest activation of IP_3 production was noted, and related to stimulation of MC3 type receptor only. There is no evidence that MC1 and MC2 receptors are coupled to pathways other than cAMP second messenger generating systems (127, 515).

That phenotypic effect of MSH is mediated through interaction with a specific cell surface receptor was first established in frog melanophores, when α -MSH was found to induce cAMP production and darkening of the frog skin (412). Studies in the mammalian system murine S91 melanoma cells were the first to show that MSH interacts with specific cell surface receptors that activate adenylyl cyclase activity that increases intracellular cAMP (569). This resulted in increases in tyrosinase activity and melanin production, stimulation of dendrite formation, and inhibition or stimulation of cell proliferation (415, 559, 563, 570–572, 571). These findings established that in mammalian melanocytes the phenotypic effects of ligand activation of MSH receptors are mediated by cAMP through activation of PKA and phosphorylation/dephosphorylation reactions (373, 551, 559, 562).

After binding the ligand, the MSH receptor is internalized and targeted to either endosomal compartments, the Golgi region, or melanosomes (107, 415, 487, 559, 561, 563, 856). Binding of MSH to the MSH receptor and the subsequent activation of adenylyl cyclase were found to be dependent on the presence of Ca^{2+} in the receptor milieu; calcium binding protein (CBP) may partially activate the receptor even in the absence of the ligand (170).

Intracellular MSH binding sites with different subcellular localization have also been detected; it has been proposed that these internal MSH receptors would participate in the regulation of cellular phenotype without circulating through the plasma membrane (107, 561). In fact, in the intramelanosomal environment MSH receptor activated signaling cascade may stimulate tyrosinase activity through mechanisms involving phosphorylation/dephosphorylation cascades (373, 551, 553, 559). Delivery of α -MSH to melanosomes could also change the physicochemical interaction of tyrosinase with 6-BH₄ to stimulate tyrosinase activity (490, 579, 666). Thus delivery of MSH-MSH receptor complex to the melanosome may be an integral regulatory step of melanogenesis (415, 487, 561), whereas its delivery into the endosomal/Golgi region may affect the posttranslational regulation of the melanogenic apparatus. It must be noted that MSH stimulates the processing of tyrosinase and tyrosinase-related proteins and the formation of melanosomes (262, 263, 515). Regulation by MSH of transcription and translation of tyrosinase and MRPs could be mediated indirectly through MITF or directly through activation of PKA- or PKC-dependent pathways. Nevertheless, there is a consensus that MSH stimulates production and activity of MRP at the transcriptional, translational, and posttranslational levels. Furthermore, MSH stimulates delivery of tyrosine to melanosomes (592). Other functions of MSH receptors including immunoregulation and its coupling to different signal transduction system in nonmelanocytic cells such as stimulation of the Janus kinase 2 (JAK2) and signal transducers and activators of transcription (STAT1) pathways, suppression of nuclear transcription factor NF κ B, inhibition of NO, and neopterin production and prostaglandin synthesis (442, 762) are outside the scope of this review.

D) REGULATION OF MSH RECEPTORS EXPRESSION. Expression and activity of MSH receptors in mammalian pigment cells are also regulated by intrinsic and extrinsic factors of which the most important is UV radiation (UVR) (63, 103, 105, 561, 747, 762). Thus Pawelek et al. (561) have proposed that UV-induced melanogenesis was mediated via upregulation of the MSH receptor system. Indeed, UVR does upregulate expression of MSH receptors, amplifying the melanogenic effect of exogenous MSH in a dose-dependent manner in vivo and in cell culture systems (63, 104, 561). In murine melanoma, UVR action appeared to involve arrest of the cell cycle at the G₂ phase, when cultured melanocytes express maximal MSH receptor activity and responsiveness to MSH (476, 561). The G₂ phase coupling of increased MSH receptor expression was associated with increased cellular responsiveness to the ligand (149, 476, 855, 901). Nevertheless, G₂-restricted expression and activity of MSH receptors appears to be specific for rodent melanocytes, since it has not been observed in a human model. In both mouse and

human melanocytes, UVR similarly stimulates expression of MSH receptors (103).

Factors known to raise intracellular cAMP levels such as MSH itself, ACTH, dibutyryl cAMP, cholera toxin, and phosphodiesterase inhibitors also stimulate MSH receptor expression and activity (105, 149, 559, 561, 762). In addition, positive cooperativity of MSH receptors has been documented in mouse and hamster melanoma cells (475, 476, 732). In normal and malignant melanocytes, interleukin (IL)-1 α , IL-1 β , endothelin-1, adult T-cell leukemia-derived factor/thioredoxin (ADF/TRX), interferon (IFN)- α , IFN- β , IFN- γ , dibutyryl cAMP, and the hormones α -MSH, β -MSH, and ACTH can stimulate expression of the MC-1 gene and of functional cell surface MSH receptors (reviewed in Refs. 442, 762). IL-1 can also stimulate MC-1 receptor expression in normal and malignant human keratinocytes (59). The melanin precursors L-tyrosine and phosphorylated isomers of L-DOPA also stimulate expression of MSH receptors and melanogenic responsiveness to MSH peptides (475, 560, 732, 748). A similar effect was described for thymidine dimers and small single-stranded DNA fragments (ssDNA) that are produced intracellularly after UV-induced damage (165, 166, 212). Retinoic acid, while stimulating MSH receptor expression, inhibits MSH-induced melanogenesis (108, 540, 541). In addition, retinoic acid and vitamin E inhibit MSH-sensitive adenylate cyclase activity in mouse melanoma cells (644). Tumor necrosis factor (TNF)- α inhibits MC1 expression in melanocytes (192). Thus, while MSH receptors are important regulators of melanocyte activity, they are also subject to positive and negative regulation by multiple factors.

The function of the MC1 receptor, being the subject of multiple regulatory inputs while also controlling melanogenesis at different levels, suggests that it represents a molecular switchboard ("molecular chip") for the various melanogenic signals. An example of such integration would be the melanogenic response to UVB, which is not a collection of random events but, instead, a highly coordinated sequence involving MSH receptors expression and activity, and local production of its ligands (MSH and ACTH peptides) that act as cofactors in the stimulation of cutaneous melanogenesis (103, 561, 747).

E) PARA-, AUTO-, AND INTRACRINE MODES OF REGULATION OF MELANOCYTIC ACTIVITY. Since the first demonstrations of POMC gene and protein expression in skin of both rodents (742) and humans (678), several laboratories have documented that skin cells can produce different POMC peptides (reviewed in Ref. 762). The relative skin concentration of POMC mRNA is, however, severalfold lower than that detected at the central level (724). The size of POMC message detected in the skin was, depending on the source, similar, larger, or shorter than the 1.1–1.2 kb usually detected in pituitary or hypothalamus (762). A short POMC mRNA of ~0.9 kb contained the coding exon 3 but lacked the sequence encoding the signal peptide

(762). Nevertheless, this cutaneous POMC mRNA was translated into the 30- to 33-kDa POMC precursor protein. Depending on tissue or cell source, the precursor is further processed to final products that included β -lipotropin (LPH), β -endorphin, β -MSH, ACTH_{1–39}, ACTH_{1–17}, ACTH_{1–13}, ACTH_{1–10}, acetyl-ACTH_{1–10}, α -MSH, diacetyl- α -MSH, and γ -MSH peptides (714, 731, 758, 821, 866, 896). Because skin cells also express the convertases PC1 and PC2 and 7B2 protein (necessary to generate enzymatically active form of PC2), POMC processing may be similar to that described at the central level, including compartmentalized processing, e.g., specific for corticotrophs and melanotrophs as in the pituitary (762). In fact, we have already detected differential, cell type-associated and hair cycle phase restricted expression of PC1 and PC2 convertases in the skin of C57BL/6 mouse (470). The final POMC peptides can potentially be produced in all cutaneous compartments (epidermis, dermis, and adnexa) by epithelial and melanocytic cells and cells of mesenchymal origin such as immune cells, fibroblasts, and endothelial cells and also by release from sensory nerve endings (reviewed in Ref. 762). Local POMC gene expression and production of POMC peptides can be modulated with UVR, cytokines, growth factors, and cAMP and varies according to phase of the hair cycle (762).

Thus locally produced melanocortins and adrenocorticotropin could regulate melanogenesis through para-, auto-, or intracrine mechanisms (762). Specifically affected cutaneous histocompartment, and prevalent signal (UV radiation, cytokines, or phase of hair cycle) would define the cell populations releasing POMC-derived peptides to change the activity of neighboring melanocytes (paracrine mechanism). The same signals (UV, IL-1, or cAMP) could even directly upregulate both POMC and MC1 receptor expression (reviewed in Refs. 442, 759, 762), implicating concerted action ("fine-tuning") of POMC expression and MC1 receptor activity. Such interactions should ensure specificity and selectivity in the final result. For example, bidirectional communication through MSH or ACTH signals between melanocytes and keratinocytes within the epidermis or anagen hair follicle would regulate production and transfer of melanin pigment to keratinocytes and thus skin or hair pigmentation. While autocrine regulation of MSH receptor activity may be operative in melanocytes *in vitro*, it is the intracrine mechanism that has a predominant role *in vivo*. Melanocytes do produce and process POMC and express intracellular MSH receptors (reviewed in Ref. 762), and a POMC processing system has been identified in human melanosomes (579). These findings underscore the specific targeting of POMC or intermediate products of its processing by internal (intracellular) MSH receptors to the target organelles. Similarly, β -endorphin and μ -opiate antigens have been colocalized in melanosomes (348). Accordingly, expression of shorter POMC transcripts encoding products lack-

ing the signal peptide would interfere with the export of POMC peptides from the cell to ensure restriction of its effect to the same cell or its immediate vicinity. Thus the cutaneous POMC system may counteract local stresses through highly restricted regional circuits that self-regulate their level of expression independent of the central nervous system (762). The system could operate at different organizational levels (cellular, tissue, and organ) via combinations of intra-, para-, and perhaps autocrine mechanisms of action (reviewed in Ref. 762). Of clinical interest, the local peculiarities of the POMC system can also explain the increased skin pigmentation of patients with Addison's disease, particularly in the sun-exposed areas. Thus the extremely high plasma ACTH levels in conjunction to UV-induced damage would overcome the dermal-epidermal barrier to reach melanocytes overexpressing MC1 receptors (758). In this context we have proposed that ACTH after binding to the MC1R could be internalized and further processed to α -MSH that would stimulate on site melanogenesis (758).

2. β -Endorphin and opioid receptors

A) AN OVERVIEW. The category of opioids is divided into those containing the message domain Try-Gly-Gly-Phe, comprising enkephalins, endorphins, and dynorphins; and those with the Tyr-Pro-Phe/Trp sequence, comprising the endomorphins-1 and -2. Receptors for these ligands represent an heterogeneous set and include the mu (μ), delta (δ), and kappa (κ) (206, 557). β -Endorphin is produced by a cleavage from the β -LPH fragment by prohormone convertase 2 (41, 137, 691) and binds with high affinity to the opiate receptors μ and δ ; and with low affinity to κ receptors (214). The genes for these receptors are similarly organized, with coding regions extending over three exons to encode extracellular, transmembrane, and cytoplasmic domains of the G protein-coupled receptors that belong to the same superfamily (884). β -Endorphin, like the opioids enkephalins and dynorphins, mediates its biological actions by activation of receptors coupled with one of multiple G proteins to regulate adenylyl cyclase, PI 3-kinase, MAP kinase pathways, and Ca^{2+} and K^{+} channels (129). Even in the absence of ligand, opioid receptors can exhibit intrinsic activity that can also be reversed by opioid antagonists.

B) ROLE OF β -ENDORPHIN IN SKIN BIOLOGY AND PIGMENTATION. β -Endorphin has been implicated in the pathogenesis of several dermatoses, for example, elevated β -endorphin plasma levels have been reported in psoriasis (215) and in atopic dermatitis (216). These similarities have been related to β -endorphin action as a differentiation factor for keratinocytes through upregulation of cytokeratin 16 expression (55). β -Endorphin plasma levels are also higher in patients with the depigmentation disorder vitiligo, whereas in the skin itself, they are higher in lesional

versus uninvolved areas (499). To date, only the μ - and ξ -opioid receptors have been localized to the skin where their expression has been detected in normal epidermal keratinocytes (53, 929), in chronic and acute wounds (54), and in epidermal melanocytes (348).

A role for β -endorphin in pigmentation has been suggested by the increased plasma β -endorphin and β -LPH levels that may occur post UVA exposure (420) with attendant skin pigmentation. β -Endorphin has been identified in normal and malignant human melanocytes *in vitro* (714) and in normal human skin (348, 763). β -LPH, the immediate precursor of β -endorphin and β -MSH, can stimulate melanogenesis in sheep (434), and elevated serum levels of β -LPH may be associated with generalized hyperpigmentation in humans (12). Studies performed with rodent malignant melanocytes have nevertheless shown a lack of melanogenic activity for β -endorphin and its different modified forms (173, 446).

The β -endorphin/ μ -opiate receptor system is prominently expressed in human epidermal melanocytes *in situ* and *in vitro*, and the peptide and its receptor are closely associated with melanin-producing melanosomes. This suggests that the β -endorphin/ μ -opiate receptor system is functionally active via its ability to upregulate melanocyte dendricity, proliferation, and pigmentation (348). Because both β -endorphin ligand and μ -opiate receptors are detected in epidermal melanocytes and keratinocytes, autocrine and paracrine mechanisms of action appear highly likely in the regulation of melanocyte physiology. In fact, the finding of a positive correlation between β -endorphin expression and melanocyte differentiation status (i.e., pigmentation and dendricity) suggests that β -endorphin expressed by epidermal melanocytes may indeed be involved in the modulation of melanocyte differentiation through autocrine control. Expression of the μ -opiate receptor also correlates positively with melanocyte differentiation *in vitro*, supporting that μ -opiate receptor expression may be upregulated by its ligand β -endorphin, similar to the binding of α -MSH to MC1R (104, 747). Both opioid agonists and the antagonist naltrexone appear to downregulate the same receptor in keratinocytes (53).

Cultured normal epidermal melanocytes treated with β -endorphin show increased melanogenesis and proliferation, providing direct evidence that the β -endorphin/ μ -opiate receptor system is functionally active in skin melanocytes (348). Importantly, these changes were of a similar magnitude to those reported for the known melanotropins α -MSH and ACTH (304, 306, 307). β -Endorphin also exerts potent dendritogenic effects in epidermal melanocytes, where it not only increases production of melanized pigment granules, but also facilitates their active transfer to recipient keratinocytes.

It is well documented that α -MSH and ACTH stimulate melanogenesis acting via the MC-1 R through the adenylyl cyclase/cAMP second messenger system (92).

Paradoxically, β -endorphin exerts similar biological actions via inhibition of the same signaling pathway. Thus opioid peptides, unlike α -MSH and ACTH, decrease the formation of cAMP (357). Nevertheless, other intracellular pathways, such as the PKC- β -dependent pathways, are increasingly being implicated in the regulation of melanogenesis (555). Experimentally, the topical application of bisindolylmaleimide, a selective PKC inhibitor, reduces skin pigmentation in guinea pig skin in vivo. Thus it is likely that β -endorphin/ μ -opiate receptor (R) interactions would signal via the PKC β -isoform to cause direct activation of tyrosinase with stimulation of melanogenesis. Alternately, the β -endorphin/ μ -opiate R signaling system could operate at the level of gene transcription increasing tyrosinase expression with consequent upregulation of melanogenesis. Of note, patients with rheumatoid arthritis exhibit localized high levels of β -endorphin in synovial fluid of affected joints (143), raising the possibility that local increases in β -endorphin might be involved in the highly restricted associated hyperpigmentation (207). Thus β -endorphin can act as a regulator of human skin pigmentation; however, its pigmentary response appears to be mediated via an MC1R-independent mechanism.

3. Endothelins and their receptors

A) OVERVIEW. Endothelin (ET) was originally described as an endothelium-derived peptide with potent vasoconstrictor activity (915), although it is also detected in a broad range of tissues (641, 710) that include skin (315). ET comprises the isopeptides ET-1, ET-2, and ET-3, the molecular forms emerging from the cleavage of three large peptide-specific prohormones (preproendothelin) by prohormone convertases, in a similar manner to that in melanocortin production (239, 317, 404). The ET receptors, ET_A and ET_B, are members of the heptahelical G protein-coupled receptor family (22, 653). The genes for the two receptors are similarly organized and have amino acid homology of 55–64% depending on the tissue tested. ET_A has very high affinity for ET-1 and ET-2 (pM range), but lesser affinity for ET-3 (nM range); in contrast, the ET_B receptor has similarly high affinity for all three ETs (22, 653). There appears to be considerable tissue specificity in the expression of ET receptors; in the skin, both ET-1 and ET-3 binding sites have been determined (corresponding to ET_A and ET_B) on micro and large blood vessels, sweat glands, epidermis, and hair follicles (367).

Endothelins affect multiple intracellular signaling pathways that may differ according to cell type and result in short-term (e.g., secretion) or longer term (e.g., proliferation) biological actions (711). Thus, upon binding to the G protein-coupled ET receptor, ET activates phospholipase C with production of IP₃ and DG, Ca²⁺ influx, and activation of phospholipase C. ET also activates phosphatidylcholine-specific phospholipase D in a step regulated by

PKC and intracellular Ca²⁺ concentration ([Ca²⁺]_i) (511) or is directly coupled to plasma membrane Ca²⁺ channels. The mitogenic effects of ET-1 are likely the result of its phosphorylation of tyrosine and threonine residues, activation of MAP kinase, upregulation of platelet-derived growth factor (PDGF) gene expression, and enhancement of *c-fos*, *c-jun*, and *c-myc* gene expression (710).

B) ENDOTHELINS AND MELANOCYTE DEVELOPMENT. Mice deficient in ET-1 or ET_A exhibit nearly identical defects in cephalic and cardiac neural crest cells subsets (124, 383), while mice deficient in ET-3 (lethal spotting; point mutation in the *ls* gene) and ET_B (piebald-lethal; deletion of the *s^l* gene) show coat color deficits (in addition to aganglionic megacolon) with absence of melanocytes (34, 288). Inactivation of the gene for endothelin converting enzyme-1 (needed for proteolytic activation of ET-1) also results in lack of skin melanocyte development, despite the presence of ET-1 in nonmelanocyte relevant sites in the embryo. A human homolog for these gene inactivation models is represented by patients with sporadic and familial Hirschprung disease, who often present with hypopigmentation of the skin and hair (600).

The involvement of the endothelin system, in the process of melanocyte development, appears to occur at a very early stage, with the critical time being E10.5 in mice implying its participation in melanoblast expansion/proliferation. Because melanocyte progenitors are also lost at a similar stage in SL or W mutant embryos (stem cell factor and *c-kit*, respectively), both systems are probably crucial for the development and survival of melanocyte progenitors. Pigmentation in *s^l/s^l* mice (ET_B null) is restricted to a narrow region of the craniofacial and caudal skin, suggesting that melanocyte proliferation is suppressed in the absence of a functional ET_B receptor (922). However, melanoblast proliferation can occur in the epidermis independently of ET-3 itself, possibly related to the binding of other endothelins to the ET_B receptor. Thus ET-3 is functionally required only for melanoblasts to begin their dorsolateral path migration.

ET-3 stimulates the differentiation of neural crest progenitors into fully mature pigmented melanocytes, melanoblast proliferation, and acts synergistically with stem cell factor (SCF; Steel factor) (612). Nevertheless, compensatory interactions of ET-3 for SCF in the survival and proliferation of those cells are not seen in vivo (534). Exposure to ETs of mouse neural crest cells expressing the early melanoblast marker dopachrome tautomerase (Dct) result in a proliferative and pigmentary response, with ET-1 and ET-3 being more potent proliferating agents than ET-2, and the response is blocked by an ET_B antagonist (536). ET receptor gene expression in tissues that include the skin appears to increase during the later stages of embryonic development to reach maximal expression immediately after birth (5).

C) ENDOTHELINS AS REGULATORS OF ADULT MELANOCYTES. Endothelin has been identified as a potent stimulator of proliferation and differentiation of human melanocytes (910). ET is in fact secreted by keratinocytes and stimulated by UVB radiation to evoke a melanocyte response characterized by proliferation and melanogenesis (315, 910). Addition of ET-1 to cultured human epidermal melanocytes results in increased tyrosinase activity and TRP-1 mRNA expression, whereas expression of the same genes in human skin is increased after UVB irradiation (313). The effect of ETs on tyrosinase activity is probably mediated via activation of PKC, elevation of cAMP, and activation of PKA (313). ETs have also been implicated in development of melanocyte dendricity (258). The ET-converting enzyme-1, which is involved in the processing and UVB-inducible secretion of ET-1 by keratinocytes, is also expressed in melanocytes (239). ETs can also cooperate and synergize with other growth factors to alter melanocyte phenotype. For example, melanocyte cultures treated briefly with ET-1 upregulate mRNA for MC1R, and also MC1R binding activity for α -MSH (192, 806). Conversely, ET-induced melanocyte differentiation may be enhanced by α -MSH, although this finding is not universal (279).

D) ENDOTHELINS AND PATHOLOGY OF SKIN PIGMENTATION. ET-1 protein expression is higher in lentigo senilis lesional skin, compared with perilesional skin; moreover, lesional skin shows increased expression of transcripts for ET-1, ET_B, and tyrosinase, as well as the ET-inducible cytokine TNF- α . Thus this type of hyperpigmentation may be associated with overactivity of the ET cascade. As regards ET-1, both binding and growth response are lower in metastatic melanoma cells than in primary melanoma cells (158). A consistent finding has been that despite significant ET receptor expression in melanoma cells, the cells exhibit reduced growth response to ET-1 compared with normal melanocytes.

4. Histamine and its receptors

A) OVERVIEW. Histamine (β -imidazolylethylamine) is generated by enzymatic decarboxylation of histidine by L-histidine decarboxylase and is stored within cell granules. In some systems, the decarboxylation step may be alternatively performed by an aromatic amino acid decarboxylase, dopa-decarboxylase (227). Intracellular histamine may participate in cellular proliferation, while histamine released into the intercellular space is catabolized to form imidazole-carboxyaldehyde, 1-methyl-histamine, or 1-methyl-imidazole-acetic acid (227). Histamine metabolism proceeds very rapidly in skin (805). Following the cloning of histamine receptors H₁ and H₂ (202, 914), their pharmacological functions have been better defined (37). The H₁ receptor is ~56 kDa and H₂ ~59 kDa (274). One additional receptor exhibits "autoreceptor" activity

(H_{3A-C}) of 70 kDa (118, 437), and a fourth histamine receptor of 85 kDa, H₄, closely related to H₃, has recently been identified (430, 507, 521). As H₄ appears to be expressed on mast cells, it may also be present in skin (931).

All four known histamine receptors are G protein-coupled receptors. H₁ histamine receptor induces functional responses by activating phospholipase C via a G_{q/11} followed by an increase in inositol phosphate, mobilization of [Ca²⁺]_i, and activation of PKC (417). H₁ can also activate other signaling pathways such as guanylyl cyclase with subsequent stimulation of NO synthase activity (927), and it can also induce the release of arachidonic acid and its metabolites prostacyclin and thromboxane A₂ (501). Histamine H₂ receptors couple via G_s protein to stimulate adenylyl cyclase activity (273). There is also evidence of H₂ coupling to other pathways including [Ca²⁺]_i, although these effects appear to be cell type specific. In contrast, signaling via H₃ receptors is more speculative (123). Signal transduction via the H₄ receptor appears to be similar to that of H₃, i.e., coupling to a G_i α protein to inhibit adenylyl cyclase (931) with subsequent mobilization of Ca²⁺.

B) CUTANEOUS HISTAMINE FUNCTION. Histamine is found at high levels in mast cells in skin, lung, intestinal mucosa, basophils in the blood, the so-called histaminocytes in the gastric mucosa, and the central nervous system. In the skin, dermal mast cells store large amounts of histamine within granules, and it mediates itching upon release. The itch sensation is abolished by epidermis removal; itching increases when integrity of the epidermis versus dermis is compromised (640). Antihistamine agents are effective treatment for pruritis associated with inflammation (1). Histamine generation has also been demonstrated in human skin keratinocytes (450), which can release up to 50% of the release from dermal mast cells (122). Histamine roles may include regulation of cell proliferation/differentiation, neurotransmission, and immunomodulation (525, 872). Histamine has been demonstrated in several skin compartments including mast cells, blood vessels, eccrine gland, hair follicles, and epidermis (341, 450).

Primary cultures of epidermal keratinocytes contain and release significant amounts of histamine, and UVB irradiation increases further its levels and also stimulates its release (450). Epidermal keratinocytes also express H₁ and H₂ receptors (183, 226), and there may even be H₃ receptors in skin, as suggested by flare responses to intradermal injections of selective H₃ agonists (349). A role for histamine in epidermal proliferation is indicated by the inhibition of reactional epidermal hyperplasia after histamine receptor antagonists have been applied to barrier-disrupted epidermis (27).

C) HISTAMINE ACTION ON MELANOCYTES. Mast cells release histamine if irradiated in the presence of photolabile red/yellow pheomelanin and pheomelanoprotein (605), but not when irradiated alone or in the presence of the pho-

tostable brown/black eumelanin. Antimalarials (e.g., chloroquine) may also alter cutaneous pigmentation by antagonizing histamine responses (372). The level of constitutive melanization of the skin does appear to affect histamine action, since direct intradermal injection of histamine phosphate induces greater wheal sizes in black versus white skin (854).

A link between histamine biology and melanogenesis may be represented by the inhibition of tyrosinase activity and melanogenesis in melanoma cells exposed to histamine H₂ receptor agonists (473). Moreover, histamine H₁ receptor antagonists (mepyramine) and H₂ receptor antagonists (cimetidine, ranitidine) appear to increase tyrosinase activity, while H₂ receptor agonists stimulated cell proliferation. H₂ receptor antagonists stimulate melanin accumulation in some melanoma lines, but this is likely to be associated with inhibition of proliferation (845).

Stimulation of the H₂ receptor increases cAMP production and tyrosinase activity in melanoma cell lines (887), although increases in tyrosinase activity, albeit minimally, are also seen with histamine H₂ receptor antagonists (e.g., cimetidine) in normal human epidermal melanocytes (408). Histamine had no effect on white or black foreskin melanocyte cultures in concentrations up to 1 μ M (325). The histamine H₂ receptor agonist analog *S*-[2-(*N,N*-dialkylamino)ethyl]isothioureia was able to depigment melanoma cells, with or without inhibition of tyrosinase, suggestive of downregulation of the message from pigmentation genes (174). However, melanocytes cultured directly with 5 μ M histamine undergo phenotypic changes that do include increased dendricity and tyrosinase protein expression (837), whereas histamine in doses as low as 0.1 μ M rapidly increase tyrosinase activity and TRP-1 protein expression. These melanogenic and morphogenic effects of histamine elicited at 0.1–10 μ M in normal human epidermal melanocytes can be inhibited by H₂ receptor antagonists (e.g., famotidine), but not by antagonists of either H₁ or H₃ receptors (923). The central involvement of signaling through the H₂ receptor was evidenced by the similar stimulation of melanocyte phenotype by an H₂ agonist (dimaprit) and by histamine itself. In the latter case, melanogenesis stimulation was likely due to accumulation of cAMP and subsequent PKA activation, as these effects could be blocked by the PKA-specific inhibitor H-89. Some of these discrepancies may be due to the varying doses of agonists and antagonists used. Furthermore, melanocyte culture conditions, such as the inclusion of growth factors (e.g., basic fibroblast growth factor), are likely to be important given the associated activation of PKA (923).

The duration of histamine exposure/treatment appears also to be important, since only patients with urticaria pigmentosa develop hyperpigmentation and not those with recurrent episodes of urticaria itself. Indeed,

pigmentation may require cooperation between histamine and other factors such as SCF (131). H₂ receptor antagonists inhibit constitutive pigmentation and also facultative pigmentation induced by UVB irradiation (923). In this regard, it is interesting to note that UVR stimulates the release of histamine from keratinocytes (450), although the inhibition of UVR-induced pigmentation is incomplete. Recently, it has been reported that histamine can increase the eumelanin-to-pheomelanin ratio in cultured normal epidermal melanocytes (405). Thus histamine may be an important mediator of UV-induced hyperpigmentation in human melanocytes.

D) HISTAMINE IN PIGMENTARY DISORDERS. The increased skin pigmentation associated with urticaria pigmentosa and systemic mastocytosis appears to result from increased local concentrations of histamine. Melanin-containing cells and mast cells may exhibit very close associations in lesions of nodular mastocytosis (532). Indeed, these lesions may even contain mast cells with phagocytosed melanin granules.

Serum histamine levels have been associated with melanoma development (494), but treatment with both histamine receptor agonists/antagonists has been associated with the induction of antimelanoma responses (767). Because mast cells often concentrate around melanoma, this could have perhaps prognostic significance (355, 617). Histamine itself can act as a growth factor and chemoattractant for melanoma cells via stimulation of H₁ receptors followed by mobilization of Ca²⁺ (827). Human melanoma cells also exhibit higher histamine levels than normal melanocytes (616) and express histidine decarboxylase, the enzyme that catalyzes the formation of histamine from L-histidine (237). In general, histamine signaling via H₁ may decrease melanoma cell proliferation, while enhancement of cell growth may result from signaling via H₂ (265, 616). Other data suggest that the impact of local histamine action may depend on number, availability, and ratio of H₁ and H₂ receptors (172). In vivo studies involving the xenografting of human melanoma cells onto SCID mice have shown that H₂ receptor antagonists can significantly improve the survival of the engrafted mice (804). Furthermore, melanoma metastases in the liver can be induced to regress if histamine is coadministered with IFN- γ (6).

5. Eicosanoids and their receptors

A) OVERVIEW. The arachidonic acid-derived eicosanoids consist of a family of lipid-derived second messengers that include the prostaglandins, leukotrienes, and thromboxane. Prostaglandins and leukotrienes signal through G protein-coupled seven-transmembrane receptors that differ in their G protein specificity. Multiple prostaglandin receptors have been cloned, and coexpression of prostaglandin receptors on the same cell leads to

opposing effects (375). Prostaglandin receptors are defined as DP (for PGD), EP1, EP2, EP3 (6 isoforms), and EP4 (for PGE), FP (for PGF), and IP (for PGI) and the thromboxane A receptor TP subtypes (26). Most of these receptors signal via increasing cAMP, but EP3 reduces cAMP levels. EP1 and FP signal via PLC. Thus it is not necessary for coexpressed prostaglandin receptors to signal via the same second messenger systems. Thromboxane A₂ signals via TP receptors (2 isoforms) and also increases phospholipase C concentrations. The profiles of leukotriene LTB₄ versus the sulfidopeptide or cysteinyl leukotrienes (LTC₄, LTD₄ or LTE₄) is mirrored by their having different receptors whereby LTB₄ binds two BLT receptors, and the cysteinyl leukotrienes bind CysLT₁ (formerly known as the LTD₄ receptor) and CysLT₂ receptors (136). Coupling via their G protein-coupled receptors (either G_s, G_i, or G_q) dictates whether the responses are pro- or anti-inflammatory (772).

B) EICOSANOIDS AND MELANOCYTES. It has long been clinically observed that inflammatory dermatoses are associated with striking changes in melanocyte function (514). Eicosanoids were the first mediators investigated for their effects on melanocyte function, since their levels are increased in skin after sunburn (60), atopic dermatitis-associated acute inflammation (643), contact dermatitis (636), psoriasis (864), and urticaria pigmentosa (835).

Cultured Cloudman S91 mouse melanoma cells respond to PGE₁ and PGE₂ by increasing tyrosinase activity and by decreasing proliferation; PGA₁ and PGD₂ inhibit cellular proliferation and tyrosinase activity, while PGF_{2α} had no effect. PGE₁, but not PGE₂ or PGD₂, increases cellular cAMP levels after 30 min of treatment (4). Eicosanoid effects on normal melanocyte function include increased pigmentation (LTB₄, LTC₄, PGD₂, PGE₂), growth (LTC₄), differentiation (LTC₄), and motility (LTC₄) (519). LTB₄ has been shown to stimulate melanogenesis directly in human melanocyte cell culture (492), while LTC₄ induces a marked decrease in pigment production in cultured cells (834), although both LTC₄ and its metabolite LTD₄ stimulate melanocyte proliferation via PKA activation (491, 492). LTC₄ is also an important regulator of melanocyte differentiation not only increasing life span of melanocytes in culture, but also facilitating nevus-like appearing colony formation via reduction/loss of contact inhibition (477). Normal human epidermal melanocytes cultured for 2 days with either PGD₂, LTB₄, LTC₄, LTD₄, LTE₄, thromboxane B₂, or 12-HETE become swollen and more dendritic, with increase in the expression of tyrosinase and TRP-1 protein; in contrast, PGE₁, PGF_{2α}, and 6-ketoPGF_{1α} did not show any significant stimulatory effect. It has therefore been suggested that arachidonate-derived chemical mediators, especially LTC₄, can induce postinflammatory hyperpigmentation of the skin (836). Phospholipase A₂, which catalyzes the release of free fatty acids from membrane phospholipids, has also been

shown to significantly upregulate expression and activity of tyrosinase in cultured melanocytes, suggesting that it may act as a mediator of UV-induced or postinflammatory pigmentation (447).

While melanocyte behavior is influenced by inflammatory mediators, the cells in turn contribute to the process by producing and releasing IL-8 and monocyte chemoattractant and activating factor in response to the proinflammatory cytokines IL-1 and TNF-α (928). Moreover, IL-1 together with LTD₄ and 12-HETE are also secreted by melanocytes (801), albeit at lower levels than in cultured keratinocytes (386). Of note, LTC₄ is a potent enhancer of melanocyte chemokinesis (491), and human melanoma cells may express LTA₄ hydrolase, catalyzing the conversion of LTA₄ to LTB₄. Similarly, considerable activity of LTC₄ synthase, which catalyzes the conversion of LTA₄ to LTC₄, may be detected in the microsomal fraction of melanoma cells (528).

C) EICOSANOIDS AND PIGMENTARY DISORDERS. Topical treatment of vitiligo lesions with PGE₂ may be associated with marginal repigmentation with hyperpigmented borders (556). Hyperpigmentation of the eyelid and of eyelashes may be a complication of topical ocular hypotensive therapy with latanoprost, a PGF_{2α} analog (269, 867). Pigmentation returns to normal upon cessation of therapy. Latanoprost is also associated with increased pigmentation of the iris in both primates and humans (599), although it does not appear to induce proliferation of iridial melanocytes. Latanoprost directly affects melanogenesis itself via activation of tyrosinase.

6. Catecholamines and their receptors

A) OVERVIEW. The catecholamines (dopamine, norepinephrine, and epinephrine) are small polar biogenic amines that are synthesized primarily by cells of neuroectodermal origin from tyrosine via its conversion to L-DOPA catalyzed by tyrosine hydroxylase (TH) with its essential cofactor 6-tetrahydrobiopterin (BH₄). L-Dopa is converted to dopamine via the enzyme aromatic amino acid decarboxylase (AADC) and then to norepinephrine (via dopamine β-hydroxylase) or epinephrine (via phenylethanolamine N-methyltransferase, PNMT) in the catecholamine storage vesicle. Catecholamines are also produced in multiple peripheral sites (44, 146), including the skin (665, 677). Classically, the catecholamines act as neurotransmitters, but they have been shown to be involved in the regulation of nearly every organ system (44, 484, 784, 789, 890), including skin function (378). The catecholamines act through G protein-coupled seven-transmembrane receptors subclassified into several α- or β-subtypes. Each adrenergic receptor subtype binds a different subfamily of G_α proteins, which interact in turn with a range of effector molecules.

B) CATECHOLAMINE ACTION ON MELANOCYTES. Catecholamines were first shown to play a role in pigmentation in nonmammalian tissues, especially amphibian chromatophores where both α - and β -adrenergic receptors are expressed. While norepinephrine and epinephrine lighten the skin of *Rana pipiens* (906), they have the opposite effect on *Xenopus* skin (91). The human epidermis has the full capacity to synthesize catecholamines (675); bioprotein-dependent TH and PNMT, the key enzymes for the biosynthesis of epinephrine, have been detected in cell-free extracts of human skin epidermis, dermis, and cultured human keratinocytes. However, these enzyme activities were not detected in cultured human melanocytes and fibroblasts. The presence of TH, PNMT, monoamine oxidase (MAO-A), and catechol-O-methyltransferase (COMT) in the epidermis was confirmed immunohistochemically (411). The biosynthesis of epinephrine in the epidermis results in the expression of increased numbers of β_2 -adrenoceptors in undifferentiated keratinocytes (786), which may control keratinocyte differentiation via increased intracellular cAMP and Ca^{2+} (665). In contrast, norepinephrine induces α_2 -adrenoceptors in melanocytes (662). Thus keratinocytes secrete catecholamines, which may be critically important for α_1 -adrenoceptor expression and signaling in melanocytes, underlining their symbiotic relation. Activation of α_1 -adrenoceptor in melanocytes results in the activation of various effector enzymes, e.g., PLC, PLA_2 , and increases in intracellular Ca^{2+} (219). Specifically, activation of PLC results in the cleavage of membrane phospholipids to yield second messengers IP_3 and DG with subsequent activation of PKC. PKC can then phosphorylate a variety of cellular substrates, not least of all two serine residues on tyrosinase (552), with moderate increases in its activity. Studies performed on cultured melanoma cells have indeed shown that epinephrine or norepinephrine as well as other adrenergic agonists can stimulate moderately tyrosinase activity and melanin production (293).

C) CATECHOLAMINE IN PIGMENTARY DISORDERS. Production of the essential cofactor for catecholamines, 6-BH₄, is enhanced in lesional and nonlesional skin of vitiligo, leading to the accumulation of the oxidized 6-BH₄. This metabolite is toxic to melanocytes in culture (665). High levels of 6-BH₄ also lead to upregulation of TH levels (505), perhaps explaining the higher levels of catecholamines in patients with vitiligo in both their skin and plasma (665). Expression of β_2 -adrenoreceptors in epidermal melanocytes obtained from vitiligo skin may be higher than in healthy controls. Epidermal cells from vitiligo patients also express higher levels of COMT activity (411). COMT is involved in the metabolism of epinephrine, norepinephrine, and dopamine and also prevents the formation of toxic o-quinones during melanin synthesis in melanocytes (765). Indeed, methylation of the melanin precursor molecule DHI by

COMT prevents its further incorporation into melanin. Melanocyte "autodestruction" by intermediates of melanin metabolism has been implicated in the etiology of vitiligo (411, 740).

B. SCF and Its Receptor

1. Overview

SCF, also known as mast cell growth factor (MGCF), *c-kit* ligand (KL), or Steel Factor (SL), is a peptide growth factor/cytokine encoded by a gene with a multi-exon structure (208). Differential splicing produces mRNAs that either include or lack exon 6, resulting in the production of two transmembrane forms of SCF; one 248 amino acids long (SCF²⁴⁸), the other 220 (SCF²²⁰). Rapid proteolytic cleavage (by increased $[\text{Ca}^{2+}]_i$, activation of PKC, and some metalloproteases) of SCF²⁴⁸ produces a soluble SCF form that dimerizes in solution. Importantly, differential effects of soluble and transmembrane forms of SCF are also seen in the dispersal and survival of melanocyte precursors (see below) (879). Normal skin keratinocytes constitutively produce SCF (435). SCF synergizes with myriad growth factors such as IL-3, IL-6, IL-7, IL-9, Epo, granulocyte-macrophage (GM)-colony stimulating factor (CSF), and G-CSF (429). Steel mice, with deletions in the SCF gene, also exhibit defective formation of germ cells leading to sterility (233), and defective microenvironment for the development of melanocytes, hence their steel-colored coat (see below) (611).

SCF signals via the *c-kit* receptor (51, 195, 917) were expressed on various cell types including melanocytes (80). The *c-kit* receptor consists of five extracellular Ig domains, one transmembrane domain, one inhibitory domain at the cytoplasm/membrane junction, and one cytoplasmic kinase domain (848). *c-kit* signaling is initiated when SCF binds to its extracellular Ig domains thereby inducing multiple interconnected signaling pathways that follow the rapid formation of *c-kit* dimers and internalization of the SCF-*c-kit* receptor complex. SCF binding not only activates receptor kinase activity, but also turns *c-kit* into a phosphorylation substrate via creation of tyrosine phosphorylated receptor docking sites on *c-kit*. Subsequent binding of multiple intracellular signaling proteins, mediating protein tyrosine phosphatases SHP-1 and SHP-2, and SH2- and PTB-containing molecules (377), as well as the phosphoinositide 3-kinase (PI3K) and phospholipase C- γ can regulate *c-kit* activity. Initial expansion of the melanoblast pool requires signaling from *c-kit*, MITF, and the ET_B receptor (EDNRB) (291). Signaling by *c-kit* also favors melanocyte proliferation (697). Thus *c-kit* can influence gene expression during the development of melanocytes in a gene-selective way.

2. SCF/c-kit in melanocytes

Mutations in the receptor tyrosine kinase *c-kit* [mapped to the white spotting (W) locus in mice] or its cognate ligand SCF [mapped to the steel (*sl*) locus in mice] (380, 496, 510) exert deleterious effects on three migratory cell lineages: primordial germs cells, hematopoietic stem cells, and melanocytes, resulting in reduced fertility, anemia, and loss of pigmentation, respectively. Mice with homozygous *c-kit* mutations have an almost white coat, while *c-kit* mutations in humans are associated with piebaldism (778, 802). Melanoblasts express *c-kit* from the time they leave the neural crest; it continues to be expressed on some, but not all, melanocytes in postnatal animals, while expression of its ligand SCF is more selective (380, 496, 510).

Studies on the role of *c-kit*/SCF signaling on melanoblast/melanocyte regulation have been based on phenotypic finding after *c-kit*/SCF signal disruption (by mutations or antibody treatment) (76, 879, 880, 922); and on the effects of SCF treatment on *c-kit* expression, melanoblast proliferation, differentiation, and apoptosis (322, 340). The *c-kit*/SCF interaction is critical for melanocyte survival (785) as shown by the induction of apoptosis in murine melanocytes after injection of a *c-kit*-blocking antibody (ACK2) (322). When ACK2 is injected just before migration of melanoblasts from the epidermis into developing hair follicles, the entire coat remains white (510, 922); with later injections patches of white hair develop and melanocytes are detected only in those hair follicles that were developed to at least stage 4 of morphogenesis at the time of ACK2 treatment (922). In adult mice hair follicle cycling, administration of *c-kit* neutralizing antibodies to depilated mice disrupts melanocyte activation during anagen (71, 510). Thus *c-kit* is also required for melanocyte activation during the murine hair cycle (71, 578). Notably, melanoblasts/cytes that enter the follicular pigmented unit retain *c-kit* expression while differentiating into melanin-producing melanocytes, whereas melanocytes that remain in the outer root sheath lose *c-kit* expression at the end of hair follicle development (578).

Epithelial-derived SCF may be the physiological regulator in the *c-kit*-expressing melanoblasts and melanocyte of mammalian skin by modulating migration and melanocyte cytoskeleton (71, 218, 685, 687, 880), differentiation (395, 444), melanogenesis (131, 444), and cell survival/apoptosis (322). At least two isoforms of SCF are present in skin (membrane-bound and soluble) (380); melanoblasts are detectable in mice deficient in membrane-bound SCF, but the cells do not disperse into the developing skin resulting in only white coat (76, 879). Correct migration and differentiation of melanoblasts appears to require the localization of membrane-bound SCF

to the basolateral cell compartment within the hair follicle epithelium (880). Moreover, hair shafts fail to pigment if SCF levels are reduced in the epidermis (50), or if there is increased competition for SCF from ectopic *c-kit* expression in the somites (156), even if the development and distribution of melanoblasts was normal before hair follicle morphogenesis. In contrast, overexpression of the membrane-bound SCF isoform, under the K14-promotor (380), and SCF release from beads implanted into organ-cultured skin results in follicular and epidermal hypermelanosis (340). Overexpression of both the soluble and membrane-bound isoforms, under the K14-promotor, produces mastocytosis (380).

The targeting of *c-kit*-positive melanoblasts to the epidermis and hair follicle appears to require chemoattractant stimuli that cosignal with *c-kit*/SCF. These stimuli include growth factors such as endothelin (314, 534) or specific adhesion molecules such as β_1 -integrin (36, 685). Further chemoattractant signals may be expressed by the hair follicle papilla, which may be an important local source of SCF production.

3. SCF/c-kit in pigmentary disorders

Mutations in the *c-kit* receptor have been identified within a continuous range of human piebaldism phenotypes (184, 211, 781). Interestingly, a common side effect of recombinant SCF therapy has been focal hyperpigmentation at the site of subcutaneous injection (131, 231). There is evidence that melanocytes in the perilesional skin of vitiligo patients may exhibit reduced *c-kit* expression (518). It must also be noted that both alopecia areata and vitiligo contain a pool of functional melanocytes in local hair follicles that is responsive to SCF stimulation (832).

The expression of *c-kit* in melanoma decreases progressively during the local growth and invasion phases (300, 406). Moreover, tumor growth and metastasis are inhibited in nude mice after forced *c-kit* expression; SCF induces apoptosis of *c-kit*-positive human melanoma cells both in vitro and in vivo (301). Nevertheless, the loss of *c-kit* expression in melanoma cells is more consistent and appears to correlate with the loss expression of the transcription factor AP-2. AP-2 is involved in gene expression in neural crest and epidermal cell lineages throughout development and adult cell differentiation (312). The *c-kit* promoter contains three binding sites for AP-2 (913). Interestingly, induction of AP-2 expression in human melanoma cells led to *c-kit* expression and inhibition of tumor growth and metastasis (300). Furthermore, *c-kit* is an imatinib mesylate-sensitive tyrosine kinase, and thus a potential candidate for the use of this drug in *c-kit*-positive melanomas (177).

C. Nuclear Receptors and Their Ligands

1. Estrogens and their receptors

A) OVERVIEW. Estrogens, C₁₈ steroids, are produced from C₁₉ androgens by the microsomal enzyme *P*-450 aromatase (*P*450arom). Estrogens are produced from testosterone or androstenedione in the ovary, testis, and adrenal gland as well as in peripheral tissues such as adipose tissue. Estrogens are essential components of female and male reproduction, with well-characterized functions in the uterus, ovaries, mammary gland, and hypothalamic-pituitary axis. The multiple estrogen actions are mediated mainly by two estrogen receptors: ER α and ER β (228, 229). ER α consists of 595 amino acids with a molecular mass of 66.2 kDa, and ER β consists of 485 amino acid residues with a molecular mass of 54.2 kDa. ER β shares 97 and 60% identity with the DNA- and ligand-binding domains of ER α , respectively. Both receptors have high binding affinity for 17 β -estradiol (E2), followed by estril and estrone.

ER α and ER β belong to a superfamily of ligand-activated transcription factors. In the absence of ligand (hormone), the receptor is sequestered in a multiprotein inhibitory complex within the nuclei of target cells. The binding of hormone induces conformational changes and promotes homodimerization of ER, which is able to bind to specific DNA response elements (estrogen-response elements). Each receptor exhibits differential tissue expression patterns during human fetal development (75). ER α and ER β mRNAs are expressed at low levels in the skin. Loss of both receptors leads to a unique ovarian phenotype, indicating that both receptors are required for the maintenance of germ and somatic cells in the postnatal ovary.

Some effects of estrogens are mediated through a mechanism independent of ER transcriptional activity (252, 282, 376). Notably, ER α binds in a ligand-dependent manner to the p85 α regulatory subunit of phosphatidylinositol-3-OH kinase [PI(3)K] (709). Thus this nonnuclear estrogen-signaling pathway requires the direct interaction of ER α with PI(3)K.

B) ESTROGENS AND MELANOCYTES. Estrogens have significant effects on many aspects of skin physiology and pathophysiology (695, 824), including skin aging, pigmentation, hair growth, sebum production, and skin cancer. The ER α and ER β are expressed in male and female nonbalding scalp skin, and their expression profiles show lack of any obvious differences in the skin between both sexes but, distinct regional localization (825). ER β is preferentially expressed in human epidermis, blood vessels, and dermal fibroblasts. In the hair follicle, ER β expression is localized to nuclei of outer root sheath, epithelial matrix, and dermal papilla cells. ER α is not clearly de-

tected in the epidermis or hair follicles. Both ER β and ER α are expressed in the sebaceous gland.

Subjects with elevated serum estrogen concentrations tend to develop increased skin pigmentation, suggesting that estradiol may be involved in the pathogenesis of melasma (chloasma). The effects of estrogens on melanogenesis are uncertain (824). The incidence rates of melanoma rise steeply in women until about age 50, but there is no confirmatory evidence of linkage to estrogens (175).

Human melanocytes derived from normal foreskin express the functional estrogen receptor (331). Estradiol treatment of those melanocytes stimulated proliferation and reduced the melanin content by *day 10*, and reduced the tyrosinase activity by *day 4* (331). In contrast, incubation of similar melanocytes with estradiol for only 24 h causes dose-dependent increase in tyrosinase activity (606), and treatment with estradiol for 2 days increases immunoreactive TRP-1 but not tyrosinase activity in cultured normal human melanocytes derived from adult forearm skin. Pituitary hormones, such as ACTH, follicle-stimulating hormone, and luteinizing hormone, increased both tyrosinase activity and immunoreactive TRP-1 (448). An estradiol-mediated increase in melanogenesis gene transcripts has been reported (361); namely, treatment of cultured melanocytes with estradiol increased the levels of tyrosinase transcripts by 1.5- to 2.5-fold, TRP-1 transcripts by 1.5-fold, and TRP-2 transcripts by 20-fold. These results suggest that the effect of estradiol on the tyrosinase activity may be influenced by multiple factors, such as culture conditions, sex, and age. In fact, estrogen has shown inconsistent effects on proliferation and tyrosinase activity of cultured human foreskin melanocytes (311).

2. Androgens and their receptors

A) ANDROGEN FUNCTION AND SIGNALING. Androgens are a group of C₁₉ steroids secreted by the adrenal glands and also the gonads. Androgens signal via the androgen receptor (AR), a member of the nuclear receptor superfamily of transcription factors that maps to band q11-12 on the X chromosome and encodes a 110-kDa phosphoprotein of 919 amino acids (111). Testosterone and 5 α -dihydrotestosterone (DHT) are ligands for the AR, and in the skin testosterone is converted to DHT by types I and II 5 α -reductases. The AR bound to either ligand is translocated from the cytosol to the nucleus where it initiates gene transcription events by binding androgen response elements (ARE) on multiple genes (79). At least two regions of the AR are involved in transcriptional activity, i.e., AF-1 and AF-2 (332).

AR activity is regulated via recruiting of activator and repressor proteins [e.g., steroid receptor coactivator-1 (SRC-1)]; although AR binding alone may directly activate

the MAPK signaling pathway (580), MAPK appears to be required for both ligand-dependent and ligand-independent activation of the AR (847). An alternative signaling pathway may involve reactive oxygen species and action on AP-1 and NF- κ B DNA binding (622).

B) ANDROGENS AND MELANOCYTE BIOLOGY. The skin is a major target of androgens and expresses androgen receptors in cells of the epidermis, dermis, sebaceous glands, and hair follicle (11). Moreover, skin has the capacity to metabolize androgens into DHT (861). Early work by Hamilton (253) uncovered a poor tanning response to UVR in white eunuchs, whereas treatment with testosterone increased melanization. Melanogenesis in localized areas of the skin can be stimulated by androgens in males (883) and in similar sites in females during their breeding season (382). In the black-pelted rat, castration decreased *in vitro* incorporation of [14 C]tyrosine into melanin, while testosterone pretreatment for 4 days reversed the effect (893). Testosterone also blocks imidazole induction of tyrosinase activity, most likely at a pretranslational level (366).

Prepubertal Syrian hamsters chronically treated with DHT exhibit increased pigmentation on dorsal costovertebral spots and scrotal skin, but not elsewhere on the skin, and estradiol had the opposite effect (147). There is regional specialization in the responsiveness of melanocytes to sex steroids, as seen in follicular and perisebaceous gland, human genital, and areolar skin (771). This skin becomes particularly pigmented after puberty and during pregnancy. Melanocytes cultured from genital skin express the AR protein in a nuclear distribution (807). Melanocytes may also metabolize testosterone to produce DHT and express type I 5α -reductase mRNA (117, 807). A synthetic androgen (methyltrienolone) stimulates tyrosinase activity, and cAMP levels in cultured melanocytes are reduced by testosterone, DHT, and methyltrienolone.

C) ANDROGENS AND PIGMENTATION DISORDERS. Women with melanoma are reported to have a better prognosis compared with men (604, 699). In mice, blocking of androgen signaling enhanced immune responses to melanoma vaccine, and improved by 10% the rate of survival (296). Oral contraceptives (containing progestins or estrogens) (822) are contraindicated if there is a personal or family history of malignant melanoma. Chloasma/melasma is one of the most commonly reported OC-related dermatoses, and this is exacerbated by sun exposure. Androgen treatment in women may also accompany a decrease in age-related skin hyperpigmentation (777). In male hypogonadism, genital skin fails to exhibit the normal puberty-associated increase in pigmentation (369), whereas male pseudohermaphroditism with complete feminization is associated with intense cutaneous pigmentation (270). Castrated mallards injected with testosterone show lower eumelanin-to-pheomelanin ratio in the flank feathers, compared with noninjected castrates. The high pheomela-

nin levels in the breast feathers of castrated birds were significantly reduced after testosterone administration, while eumelanin content increased (238). There is some evidence that generalized vitiligo may be improved by oral administration of a preparation containing testosterone and estrogen (502).

3. Vitamin D and its receptors

A) OVERVIEW. Vitamin D₃ is formed in the skin by UVB light (wavelengths 290–315 nm) (877). Rapid photolysis (i.e., bond cleavage) converts 7-dehydrocholesterol to previtamin D₃, a thermodynamically unstable sterol that subsequently isomerizes, via double bond rearrangements, to vitamin D₃. Circulating vitamin D₃ must be converted to its active form 1,25-dihydroxycholecalciferol. Thus 25-OHase in the liver converts vitamin D₃ into 25-hydroxycholecalciferol, and in the kidneys it undergoes further hydroxylation to either 1,25-dihydroxycholecalciferol (via 1-OHase) or 24,25-dihydroxycholecalciferol D (via 24-OHase). Both 1-OHase and 24-OHase are expressed in cultured keratinocytes (409) and in skin (680).

The nuclear receptor for vitamin D (VDR) is expressed on several target tissues that include the skin (284). VDR is a transcription factor and member of the steroid nuclear receptor superfamily, and in human epidermis binds its enhancer element as heterodimers with retinoid X receptor. Vitamin D is also involved in cytoplasmic signaling events, i.e., nongenomic signaling pathways, stimulating Ca²⁺ transfer across the intestine within 1–2 min (833). Interactions between nongenomic and genomic routes occur via either direct phosphorylation of the nuclear VDR or via the upregulation of genes with VDREs, which themselves encode signaling molecules, e.g., phospholipase C- γ . Vitamin D signaling has important implications for cell growth, differentiation, and apoptosis of skin cells, particularly keratinocytes, which may indirectly regulate melanocyte behavior in skin. Vitamin D-associated antiproliferative effects are centered on the G₁/S checkpoint of the cell cycle, where at pharmacological levels it inhibits/arrests the cell cycle. Control of human keratinocyte growth by vitamin D may also involve transforming growth factor (TGF)- β 2. Also, calcipotriol, a 1-25-dihydroxyvitamin D₃ [1,25(OH)₂D₃] analog, increases expression of p21 (which contains a VDRE) in normal skin (596). Vitamin D may reduce keratinocyte proliferation via downregulation of the epidermal growth factor receptor (466). Vitamin D₃ also plays a role in keratinocyte differentiation possibly via an increase in intracellular Ca²⁺ (56).

B) VITAMIN D AND MELANOCYTE BIOLOGY. Melanocytes *in situ* express the VDR (481, 791), with possible tyrosinase-activating and melanogenic effects. Although some authors have reported increased tyrosinase activity after vitamin D₃ treatment (606, 839), others reported no effect

(3, 455). Topical application of 100 μg cholecalciferol to ear epidermis in mice for a week increased DOPA-positive melanocytes, and this effect synergized with UVB (3). However, cholecalciferol added to human melanocyte cultures did not effect melanocyte proliferation, tyrosinase activity, or melanogenesis. Instead, a $25(\text{OH})\text{D}_3$ and $1,25(\text{OH})_2\text{D}_3$ may have suppressed tyrosinase activity in these cultures. In murine melanocyte precursors $1,25(\text{OH})_2\text{D}_3$ can induce differentiation, including induction of tyrosinase and DOPA activity, established from mouse neural crest cells (871).

C) VITAMIN D AND PIGMENTARY DISORDERS. Proliferation of human melanoma cells (expressing the VDR) is inhibited by $1,25(\text{OH})_2\text{D}_3$ (125, 171), and B16 melanoma cells are induced to differentiate, with an increase in both tyrosinase activity and melanogenesis after treatment with vitamin D_3 (527). However, not all melanoma cells express the VDR, or do so at very low levels, and so may not be as responsive to the antiproliferative effects of $1,25(\text{OH})_2\text{D}_3$. The presence of the VDR may also enable $1,25(\text{OH})_2\text{D}_3$ to induce apoptosis in melanoma cells (138). Vitamin D_3 may inhibit migration of melanoma cells on extracellular matrix and in some melanoma cell lines downregulates, transcriptionally, the α_6 -subunit of the integrin laminin receptor (256). Melanoma patients may present with lower levels of $1,25(\text{OH})_2\text{D}_3$ in their sera (130). Polymorphisms at the VDR have been suggested to influence susceptibility to malignant melanoma (309). Furthermore, certain VDR genotypes may be associated with red hair in melanoma patients, similar to the case at the MC1R. Hyperpigmentation may occur after topical calcipotriol use in patients with psoriasis (370, 788). Moreover, there is some evidence that topical calcipotriol may be effective in the treatment of vitiligo (912). In another study calcipotriol was effective even in patients that had previously responded poorly to topical corticosteroids and PUVA (14). One possible explanation of the repigmentation noted after calcipotriol therapy may be stabilization of aberrant Ca^{2+} homeostasis in vitiligo skin (keratinocytes and melanocytes) (668, 669) by increasing expression of VDR in treated skin (610).

D. Other Positive Regulators of Melanogenesis: Bone Morphogenic Proteins

1. Bone morphogenic proteins and their receptors

Originally discovered as an osteoinductive extract derived from bone matrix, the bone morphogenic proteins (BMPs) consist of a family of dimeric proteins (BMP-2 to BMP-15) that belong to the TGF- β superfamily (905). In species as diverse as worms, flies, frogs, and humans, BMPs play multiple pivotal roles including development, especially in the specification of positional information in the embryo. These secreted signaling molecules also reg-

ulate several aspects of cutaneous development and function via their participation in cell proliferation, differentiation, and death (70). In addition to their involvement in epidermal homeostasis, hair follicle growth/cycling, and melanogenesis, evidence is accumulating to implicate these molecules in cutaneous pathologies such as in carcinogenesis, hyperproliferative disorders (e.g., psoriasis), wound healing, and innervation. Biologically active BMPs are released extracellularly as homo/heterodimers after cleavage of precursor proteins. Transduction of BMP signaling ensues after the formation of a high-affinity heterotetrameric complex that incorporates the binding of BMP to BMP-specific type I and II receptors and in some cases to other members of the TGF- β receptor superfamily. Two independent signaling pathways appear to be activated by BMPs including a canonical pathway involving the phosphorylation of cytosolic Smad family proteins, resulting in their translocation to the nucleus where they can alter gene transcription. Alternatively, BMPs can signal via a noncanonical or BMP-MAP kinase pathway. BMP binding to its receptors can be antagonized by noggin and follistatin among others with higher affinity to BMP than the latter has with the BMP receptor complex.

2. Bone morphogenic proteins and melanogenesis

BMPs and their associated downstream transcription factors also influence neural crest-derived cell populations, including melanocytes, in several species. For example, BMP-2 specifically targets tyrosinase gene expression in primary quail neural crest cultures resulting in increased melanin synthesis (58), although BMP-2 does not regulate melanocyte differentiation per se. Furthermore, BMP-4 may stimulate proliferation of normal human melanocytes in culture, likely via the proliferation-associated receptor BMPR-IA (909). BMPR-IA and BMPR-IB proteins are also expressed in retinal pigment epithelium of rat eyes (520). Unlike the BMP-2 effect in quail melanocytes, BMP-4 treatment of human cutaneous melanocytes reduces the expression of mRNA and protein for tyrosinase and the tyrosinase activator PKC- β . Production of BMP-4 is greater in melanocytes than keratinocytes, suggesting that this BMP may be an autocrine factor for melanocytes. In contrast to its effect in human melanocytes, purified BMP-4 reduces the number of melanocytes in cultures of avian neural crest cells (337, 857). Since in these cultures Wnt signaling appears to select melanocytes at the expense of neuronal and glial lineages, Wnt and BMP signaling may have antagonistic functions in cell fate determination in the trunk neural crest.

Recently, pigmentation defects in the hair follicle were reported to occur in Noggin transgenic mice (698). Overexpression of Noggin, an antagonist of BMP-2 and BMP-4, in agouti mice resulted in a wide range of pheno-

types including accelerated hair follicle development, up-regulation of keratinocyte proliferation, and downregulation of apoptosis in the hair bulb. In addition, these mice exhibited increased eumelanogenesis in hair bulb melanocytes that replaced the normal agouti pheomelanogenesis that occurs in wild-type mice. Thus the switch between eumelanogenesis and pheomelanogenesis may be in part regulated by the BMP signaling pathway. There has been a single report showing that BMP is expressed in ocular melanoma tissue (42).

E. Summary

Therefore, among the myriad factors regulating melanogenesis, the melanocortin/MC1R complex stands out as being the most important. The demonstration of receptor upregulation by UV light is particularly interesting, indicating a novel site for physicochemical interactions with the environment. Other important positive regulators of melanin pigmentation include endothelins, histamine, eicosanoids, and SCF acting via interaction with cell surface receptors. Sex steroids and vitamin D can also modify cutaneous pigmentation. Thus the substantial overlapping in positive regulation of melanogenesis does exist. In this context detailed characterization of animal genetic background becomes indispensable for the evaluation of mechanisms in pigimentary control in gene knockout experimental models.

V. HORMONAL INHIBITORS OF MELANOGENESIS AND RECEPTORS

A. G Protein-Coupled Receptors and Their Ligands

1. Serotonin and its receptors

A) OVERVIEW. Serotonin is the product of a multistep metabolic pathway involving hydroxylation of L-tryptophan, followed by enzymatic decarboxylation (352, 486). Mammalian skin can both synthesize and metabolize serotonin by either arylalkylamine *N*-acetyltransferase (AANAT) (205, 749, 750, 752, 757) or arylamine *N*-acetyltransferase type 1 (NAT-1) (751) to produce *N*-acetylserotonin (NAS), and possibly melatonin (717, 752). Serotonin by itself can act as neurotransmitter, regulator of vascular tone, immunomodulator, and growth factor; in the skin it exerts proedema, vasodilatory, proinflammatory, and/or pruritogenic actions (96, 352, 694, 759). Serotonin actions are mediated via interaction with membrane-bound receptors categorized into seven families (5HT1–7) with at least 21 subtypes (811). Skin cells express mRNA encoding serotonin receptors 5HT-1A, -1B, -2A, -2B, -2C, and 7, and serotonin shows variable effects on cell proliferation (753).

B) EFFECTS OF SEROTONIN AND ITS METABOLITES ON MELANOCYTES. Serotonin may be involved in the regulation of apoptosis and proliferation of melanocytes through receptors expressed by normal and malignant melanocytes (753). Thus serotonin uptake inhibitors appear to inhibit melanization in human melanoma cells (472). In human SKMEL-188 melanoma cells serotonin inhibits in a dose-dependent fashion DMEM-induced melanin production and tyrosinase activity (Fig. 10). The serotonin metabolites NAS and 5-methoxytryptamine (5-MT) are nevertheless devoid of effect on induced melanogenesis in rodent melanoma cells and histocultured anagen skin; however, they can stimulate or inhibit cell proliferation, but only at extremely high concentrations of ligands (close to millimolar) (719, 755).

2. Melatonin and its receptors

A) MELATONIN PRODUCTION. Melatonin is transformed from serotonin through a two-step pathway involving serotonin acetylation by AANAT to NAS, and methylation by hydroxyindole-*O*-methyltransferase (HIOMT) to produce melatonin (793, 926). Melatonin is produced predomi-

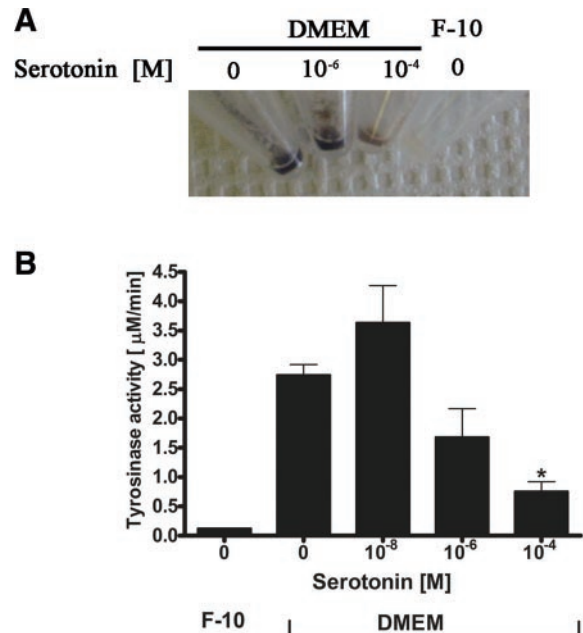

FIG. 10. Serotonin inhibits DMEM-induced melanogenesis in SK-MEL-188 human melanoma cells. Cells were cultured in F-10 medium or in DMEM medium containing 5% fetal calf serum with the following concentrations of serotonin (0, 10⁻⁸, 10⁻⁶, or 10⁻⁴ M). Media were exchanged every 24 h, and serotonin was added every 12 h. After 3 days cells were collected and DOPA oxidase activity of tyrosinase was measured in cell extracts. Results are means \pm SE; $n = 3$, * $P < 0.05$ (ANOVA and Tukey's multiple comparison post hoc test, Prism 4.0, GraphPad, San Diego, CA). It is evident that serotonin at high concentration inhibits both melanin synthesis (A) and tyrosinase activity (B). The experiments were repeated two times with similar results. (They were performed by Dr. Blazej Zbytek.)

nantly in the pineal gland but also in other organs (926) that include skin (753, 759).

B) BIOLOGICAL FUNCTION OF MELATONIN AND ITS RECEPTORS. Systemically, the main biological roles of melatonin are regulation/modulation of circadian rhythm, seasonal reproduction, and retinal function (926). Depending on production site and target organ, melatonin can act as a hormone, neurotransmitter, cytokine, or biological modifier. Melatonin effects are mediated through interactions with high-affinity membrane-bound or nuclear melatonin receptors. In addition, it has antioxidative properties and free radical-scavenging activity (102, 347). In mammals two distinct seven-transmembrane domain G protein-coupled receptors have been cloned and named MT1 (Mel1a) and MT2 (Mel1b) (613, 615). The two receptor subtypes that show 60% homology at the amino acid level can inhibit adenylyl cyclase via pertussis toxin-sensitive G_i proteins. In addition, MT1 receptors can control calcium mobilization through pertussis toxin-insensitive $G_{q/11}$ proteins, and MT2 receptors may be coupled to cGMP inhibition. Both receptors are widely expressed (614). Expression of melatonin receptor genes has been detected in both human skin and cultured skin cells (753), whereas specific melatonin binding sites have been found in melanomas and rodent skin (reviewed in Ref. 759).

C) MELATONIN EFFECTS ON THE PIGMENTARY SYSTEM. Melatonin was first isolated from pineal gland, and its biological activity was defined by its lightening effect on frog skin where it induces melanosome aggregation around the nucleus of melanophores (242). The lightening response of melatonin on skin of lower vertebrates depends on species and source tested (139, 176, 242, 874). Melatonin in a dose-dependent manner reverses the darkening response to α -MSH. In furry animals of subarctic or northern latitudes, circulating or local melatonin levels may participate in the seasonal changes in pelage color (874). Subcutaneous melatonin implants inhibit pigmentation of regrowing hairs (after depilation) in the short-tailed weasel, during molting in white-footed deermouse and Syberian hamsters (874), and may attenuate melanosis in dogs (874). An effect of melatonin on skin pigmentation in humans is uncertain (471, 516).

In cultured hair follicles from Siberian hamsters, melatonin inhibits basal, MSH, or cAMP-stimulated melanogenesis through post-tyrosinase mechanisms (431, 432, 875). High concentrations of melatonin also inhibited tyrosinase activity in histocultured skin from C57BL/6 mouse with hair follicles at anagen stage, although NAS or its metabolite 5-MT was without effect (719). Similar results were observed in Bomirski hamster amelanotic melanoma cells and Cloudman mouse melanoma cells (755). These actions represent antagonistic activity of melatonin against inducers of melanogenesis (L-tyrosine or MSH), since noninduced or already melanized cells did not react to melatonin (755). The requirement for high concentra-

tions of melatonin to elicit its antimelanogenic effect suggests that melatonin is not acting through melatonin receptor, e.g., this is either a metabolic effect or it interacts with a receptor for unrelated ligand. Similar inhibitory effect of melatonin on MSH stimulated melanogenesis was found in B16 melanoma, but at much lower concentrations (850). Specific melatonin binding sites have been found in mouse, hamster, and human melanoma lines (705, 755); functional melatonin receptors were found in normal and malignant uveal melanocytes (298, 299, 625). Melatonin receptor gene expression was reported in human normal and malignant epidermal melanocytes (753). Melatonin signal transduction in hamster melanomas appears to be coupled to phosphoinositide hydrolysis (163), while in human and rat retinal pigment cells melatonin receptors appear to be negatively coupled to adenylyl cyclase (506).

3. Dopamine and its receptors

Dopamine is an endogenously produced catecholamine whose actions are mediated through specific cell surface receptors coupled to G proteins. They are grouped into two main superfamilies (D1-like and D2-like) based on biochemical, pharmacological, and molecular characteristics (15). Strong evidence suggests that the melanocortin and dopamine systems are functionally linked (425). Dopaminergic compounds exert inhibitory effects on the pituitary content and secretion of α -MSH and β -endorphin, while dopamine receptor agonists and antagonists may also affect the level of POMC mRNA expression in the pituitary (35, 114). There are also data suggesting competitive interaction between α -MSH and the receptor agonists on the D1 receptor (421).

A) DOPAMINE AND MELANOGENESIS. The specific dopamine receptor D2 agonist (LY 171555) has been reported to inhibit hair follicular melanogenesis in pubertal (eumelanin phase) C3H-HeA mice (88); the decrease in tyrosinase activity was reversed by treatment with the D2 receptor antagonists sulpiride. However, no inhibition of hair follicular melanogenesis was observed in adult (pheomelanin phase) mice. Thus different control mechanisms may be operative during periods of eumelanin and pheomelanin synthesis.

Tyrosinase oxidizes dopamine to produce melanin via dopamine quinone (485), although dopamine quinone itself can in turn inactivate tyrosine hydroxylase (908). Dopamine excess generates reactive oxygen species and is associated with toxic effects on catecholaminergic cell lines (396). Viability of the cells is reduced if tyrosinase activity is selectively inhibited by phenylthiourea or 5-hydroxyindole (25, 271). Idiopathic Parkinson's disease is associated with massive cell death in the dopamine-derived neuromelanin-pigmented tyrosinase-positive substantia nigra (281, 826). Indeed, there is a direct correla-

tion between cell loss and percentage of neuromelanin-pigmented neurons remaining in this region with greater relative sparing of nonpigmented than of neuromelanin-pigmented neurons.

The D1B receptor has been implicated in modulating phagocytosis by retinal pigment epithelium while the D4 receptor is thought to be involved in the inhibition of melatonin synthesis in photoreceptors (508). Moreover, movement of photoreceptor cells and migration of melanin granules in retinal pigment epithelial cells as well as synthesis of melatonin in photoreceptors are mediated by D2 receptors (679). Dopamine treatment results in dispersion of black and red pigments within chromatophores in the crab *Gecarcinus lateralis*, which could be blocked by the dopamine antagonist haloperidol (459).

B) DOPAMINE AND MELANOCYTE DISORDERS. In vitiliginous skin sections, both epinephrine and dopamine can enhance melanogenesis in dendritic but not in nondendritic melanocytes, suggesting variable responsiveness in melanocytes of different differentiation states (327). D1 receptor mRNA has been demonstrated in mouse melanoma cells, but not in human metastatic melanoma cells (66). Similarly, D2 receptor mRNA was not detected in melanoma cells, and all metastases were receptor negative by immunohistochemistry (67). Thus antitumor effects against melanoma cells are probably mediated by toxic products of dopamine oxidation (888). Because of their cytotoxicity, dopamine and their metabolites may play a role in pathogenesis of vitiligo (135, 495).

4. Acetylcholine and its receptors

One of the important neurohormonal components of the skin is the epidermal cholinergic system (82, 220–222). Its neurotransmitter, acetylcholine (ACh), is synthesized from acetyl coenzyme A in keratinocytes by the enzyme choline acetyltransferase. After secretion, ACh interacts with muscarinic and nicotinic cholinergic receptors expressed predominantly in the basal or suprabasal epidermal layers, to regulate keratinocyte proliferation, migration, and differentiation. ACh availability is also determined by its local degradation through the action of acetylcholinesterase (AChE), present at its highest levels in the basal keratinocyte layer, to decrease gradually along the vertical axis, with the lowest concentrations below the stratum corneum. In addition to local synthesis, cutaneous ACh is also derived from skin cholinergic nerve endings release.

ACh is produced from choline (in the diet) and acetyl CoA via choline acetyltransferase, and is thereafter metabolized to choline and acetate by AChE. Human epidermal keratinocytes express cholinergic enzymes and can synthesize, secrete, and degrade ACh (221–223). Expression of choline acetyltransferase has also been detected in skin appendages (338). There is some evidence that ACh

metabolism may be altered in some dermatoses, e.g., atopic dermatitis (234) and melanoma, where expression of ACh receptors has been linked to invasiveness (646).

ACh interacts with two subclasses of cholinergic receptors, muscarinic and nicotinic. Direct actions occur at nicotinic receptors, while indirect action occurs via second messengers at G protein-coupled muscarinic receptors. Human epidermal keratinocytes express both nicotinic and muscarinic cholinergic receptors on their cell surfaces which bind ACh and initiate cellular responses that include maintenance of cell viability, proliferation, adhesion, migration, and differentiation (220–223). Calcium is the mediator of ACh effects in keratinocytes, which in turn regulate expression and function of cholinergic enzyme and cholinergic receptor in these cells. The epidermis expresses several nicotinic cholinergic receptors (nAChR) that can change in number and subunit composition dependent on their differentiation status. They are ion channel-coupled neurotransmitter receptors that upon ACh binding maintain keratinocyte viability and aid cell differentiation. In contrast, muscarinic G protein-coupled receptors respond more slowly, with M1, M3, and M5 receptors stimulating phosphoinositide metabolism and M2 and M4 receptors inhibiting adenylyl cyclase. Muscarinic receptor pathways can regulate keratinocyte proliferation and migration.

A) ACETYLCHOLINE AND MELANOGENESIS. As in other neural crest-derived cells, melanocytes express cholinesterase activity and muscarinic receptors during their migratory phase, in the embryo. Thus it is altogether likely that these cells are responsive to ACh, as has already been shown for melanoma cells (646; see below). ACh appears to inhibit melanogenesis and also has an inhibitory effect on dopa oxidase activity of marginal melanocytes in vitiligo (326). Similar inhibition of melanin synthesis was demonstrated in human melanoma cells (83). In a study designed to assess the effects of prostaglandins on human iridal pigmentation, ACh (used as another test substance in this study) was found not to affect pigmentation (43). Still, all five mAChR subtype mRNAs have been detected in normal human melanocytes, and expression of the receptors themselves was noted in human skin specimens by immunohistochemistry (82). Similarly, mAChR subtypes (m2 and m3) have been detected in the retinal pigment epithelium of chick (178, 186, 545) and humans, where they are coupled to phosphoinositide hydrolysis and Ca^{2+} mobilization. Melanocytes in culture express ~9,000 high-affinity receptors per cells, and micromolar concentrations of muscarine or carbachol can transiently increase intracellular Ca^{2+} . Thus these receptors may regulate melanocyte behavior and skin pigmentation by affecting the intracellular concentration of free Ca^{2+} (82). However, the literature is inconsistent here, whereby some reports suggest that muscarinic ACh receptors are expressed in human melanomas but are not present in normal skin melano-

cytes. Notably, nevocytes were positive for muscarinic receptors (399, 646).

B) ACETYLCHOLINE AND MELANOCYTE DISORDERS. An auto-crine muscarinic cholinergic system has been reported in human melanoma (646); thus muscarinic acetylcholine receptors were detected in primary and metastatic human melanomas, as was choline acetyltransferase and cholinesterase activity in melanoma cell lines (646). Moreover, the expression of muscarinic receptors appeared to be associated with melanoma cell contractability. Since the same investigators did not detect ACh receptors in normal melanocytes, they concluded that their reexpression in melanoma cells, after transient expression during embryogenesis, may be involved in melanoma invasive growth. The expression of muscarinic receptors in primary malignant melanomas appears to be heterogeneous and correlates with melanoma cell infiltrative and metastatic capacity (399). Tumor cells located centrally were found to express little or low levels of ACh receptor while melanoma cells intensely ACh positive were located around this negative center as clusters of atypical melanocytes. Interestingly, melanoma cells infiltrating the surrounding normal tissue were also reported to express muscarinic receptors (399). One study has reported a lower level of acetylcholinesterase activity in vitiligo skin compared with normal skin (326). Moreover, perilesional regions of depigmenting vitiligo epidermis containing dendritic melanocytes were negative for acetylcholinesterase, becoming positive upon repigmentation. The author concluded that lower acetylcholinesterase activity in melanocytes may result in increased inhibition of melanocyte ACh aggravating depigmentation in vitiligo.

B. Melanocortins Antagonists

1. *Agouti* protein

Agouti coloration is typically seen in the wild-type color of mice as a banded pigmentation pattern of the pelage, in which each hair is black with a subapical band of yellow. The *agouti* locus (*a*) on mouse chromosome 2 regulates the cyclical production of black and yellow pigment granules, thereby generating the agouti coat color of the mouse (708, 897). Agouti protein acts within the microenvironment of the hair follicle during hair growth, switching eumelanin synthesis into pheomelanin synthesis.

The mouse *agouti* gene encodes a 131-amino acid polypeptide with a signal peptide; the mature protein has 10 cysteine residues near the carboxy terminus (87). *Agouti* gene transcripts of 0.8 kb are expressed in the testis and skin but not in melanocytes (87). Alternative isoforms of agouti mRNA contain different noncoding first exons located 100 kb apart, and their expression is controlled by regulatory elements that are either ventral specific or hair

cycle specific (865). The agouti protein is produced in dermal papilla cells (482). Recessive *agouti* mutations result in all-black hairs, while the dominant alleles cause an all-yellow phenotype in mice. Structural alterations in the *agouti* gene cause detectable changes in the expression of gene transcripts; for example, the 0.8-kb mRNA is not detected in the skin of C57Black mice carrying the *a* mutation (87).

In humans, the agouti gene has been mapped to chromosome 20q11.2 and encodes a protein of 132 amino acids with 85% homology to the mouse agouti protein (390, 892). The human agouti gene is expressed in adipose tissue, testis, ovary, and heart and at lower levels in liver, kidney, and foreskin (892). Expression in transgenic mice of the human agouti protein, also named agouti signaling protein (ASP), produced a yellow coat (892), although human hair does not show the agouti pattern. Expression of ASP in cell culture blocks the α -MSH-stimulated accumulation of cAMP in mouse melanoma cells (892). Notably, agouti protein is produced in a hair stage-specific manner and functions as antagonist for the MC1R (439). MC1R is encoded by the *extension* (*e*) locus on mouse chromosome 8 (624). Dominant *extension* locus mutations are associated with the all-black phenotype of recessive *agouti* mutations, while recessive *extension* locus mutations cause the all-yellow phenotype as in dominant *agouti* mutations.

A dominant *agouti* mutation, *lethal yellow* (A^y), has received particular interest, because in addition to an all-yellow phenotype, *lethal yellow* heterozygotes display profound obesity, diabetes, and increased tumor susceptibility. The *lethal yellow* heterozygotes overexpress a larger agouti transcript in all tissues examined (87, 483). This aberrant expression is due to chromosomal rearrangement that results in the production of a chimeric gene and mRNA of ~ 1.1 kb. The *lethal yellow* mutation is caused by a 120-kb deletion in the *agouti* gene (153), where the first exon is replaced by a novel sequence on the *lethal yellow* mRNA, but the 3'-portion of the mutant RNA retains the intact protein-coding region of the *agouti* gene. The DNA source for the 5'-novel sequence of *lethal yellow* RNA is the 5'-noncoding exon of a previously uncharacterized gene, termed *Raly* (480) or *Merc* (153). *Raly/Merc* may represent an RNA-binding protein; it is expressed in preimplantation embryo, throughout development, and in adult tissues, but *Raly* is not expressed in the *lethal yellow* allele. Thus the dominant pleiotropic effects associated with A^y mutation may result from ectopic overexpression of the wild-type *agouti* gene product under control by the *Raly* promoter, and the recessive embryonic lethality may be the results of the lack of *Raly* gene expression in the early embryo.

Murine agouti protein causes both time- and concentration-dependent suppression of melanogenesis in B16 F1 murine melanoma cells, while the same protein has

minimal or no effect on α -MSH stimulation of melanogenesis (305). Similar to the murine protein, human agouti protein decreased melanogenesis in cultured human epidermal melanocytes, and markedly inhibited pigmentation and the production of eumelanosomes in black eumelanogenic murine melanocytes (652). In the latter, melanosomes became pheomelanosome-like in structure, and eumelanin production was significantly decreased. Agouti protein also induced time- and dose-dependent decreases in melanogenic genes expression, including those encoding tyrosinase, tyrosinase-related protein 1, and TRP2/DCT. Agouti protein coordinately regulates lipid metabolism in adipocytes. Dietary composition influences the pigmentary phenotype in viable yellow agouti mice (873). Maternal supplementation of *a/a* dams food with extra folic acid, vitamin B₁₂, choline, and betaine did switch fur color in *A^{vy}/a* offsprings from yellow (agouti) towards brown (pseudoagouti) phenotype. It was concluded that in mammalian systems transposable elements can serve as targets for early nutritional effects on epigenetic gene regulation of which *A^{vy}* is an example (873).

A) AGOUTI-RELATED PROTEIN. Agouti-related protein (AGRP) was identified from a search of the EST database using the sequence of agouti protein as a template (706). Ubiquitous overexpression of human AGRP cDNA in transgenic mice caused obesity without altering pigmentation (533). The human AGRP gene exhibits polymorphisms both in its promoter and coding regions, which could affect the expression levels of AGRP and expression of phenotype (23, 469, 863). Like agouti protein, AGRP contains a putative signal sequence and a cysteine-rich carboxy terminus. AGRP functions as a paracrine-signaling molecule that regulates body weight in the hypothalamus by antagonizing signaling through MC3R and MC4R. This orexigenic function of AGRP is responsible for the obesity seen in *lethal yellow* (*A^y*) mice, in which agouti protein is aberrantly overexpressed in many tissues, including the brain, and mimics the function of AGRP. Conversely, AGRP does not bind MC1R in vitro, as determined by its failure to induce cAMP accumulation in the cells overexpressing MC1R (533), and by direct binding assay (916). However, AGRP does appear to inhibit the binding of agouti protein to MC1R (533). The latter observations suggest that AGRP and agouti protein may share a binding site on MC1R. However, in transgenic mice, AGRP has no noticeable effect on pigmentation (533).

2. Agouti modifiers

A) ATTRACTIN OR MAHOGANY. The mahogany (*mg*) locus was identified as the source for a recessive suppressor of agouti protein; namely, functional mahogany protein is required for the action of agouti protein that modifies coat color by antagonizing the MC1R. Mahogany is a 1,428-

amino acid, single-transmembrane domain protein that functions as an accessory receptor for agouti protein and is expressed in many tissues, including pigment cells and the hypothalamus (236). The extracellular domain of the mahogany protein is the ortholog of human attractin, a circulating molecule produced by activated T cells, suggesting a molecular basis for cross-talk between melanocortin receptor signaling and immune function (236). These two proteins are generated by alternative splicing of mRNAs. Attractin (*Atrn*) is a low-affinity receptor for agouti protein, but not AGRP (260). Attractin affects the balance between agonist and antagonist at receptors on melanocytes and mediates interactions between activated T cells and macrophages.

Attractin is also involved in the control of metabolic rate and feeding behavior independent of its suppression of agouti (148). Mice homozygous for the *Atrn(mg-3J)* allele have reduced body weight due to increased energy expenditure.

B) MAHOGANOID OR MAHOGUNIN. The mutant mahoganoid (*md*), also known as Mahogunin (*Mgrn1*), darkens the coat color and decreases the obesity of *A(y)* mice that aberrantly overexpress agouti protein. Pigmentary phenotype and genetic interactions of mahoganoid are similar to those of *Atrn*. The mahoganoid trait prevents hair follicle melanocytes from responding to agouti protein. Mahoganoid encodes a 494-amino acid protein containing a C3HC4 RING domain that may function as an E3 ubiquitin ligase (260, 582). The human homolog is 81% identical to mice in the primary structure, and its gene maps to 16p13.3. Like *Atrn* mutations that cause spongiform neurodegeneration, a null mutation for mahoganoid causes age-dependent neuropathology (261). The mahoganoid protein may represent a component of a conserved pathway for regulated protein turnover, which is essential for neuronal viability.

3. Melanin concentrating hormone

A) OVERVIEW. In amphibians and fishes, a dual hormonal control of color change is regulated by two antagonistic pituitary melanophorotropic hormones, MSH and melanin-concentrating hormone (MCH). MCH is a 17-amino acid cyclic peptide that was originally isolated from chum salmon pituitaries (350). Salmon MCH induces melanosome aggregation within melanophores of teleost fish (whitening of the color). MCH is present in the neurons of lateral basal hypothalamus of fishes, and MCH-immunoreactive axons project into the brain and pituitary (504). In addition, salmon MCH has a potent inhibitory action on CRF-induced α -MSH and ACTH secretion in vitro by teleost pituitary glands (30).

Human MCH, a 19-amino acid cyclic peptide, is identical to rat MCH (503, 595, 858), but differs from salmon MCH by an amino-terminal extension of two amino acids

and four additional substitutions. MCH is an orexigenic neuropeptide showing opposing and antagonistic actions to α -MSH on feeding behavior and energy homeostasis through a mechanism other than interference with the MC3 or MC4 receptor (441). The MCH receptor of 353 amino acids was identified as the orphan G protein-coupled receptor SLC-1 that is sequentially homologous to the somatostatin receptor (110, 649). The receptor SLC-1 is stimulated by MCH to mobilize intracellular Ca^{2+} and reduce forskolin-elevated cAMP levels (110). Subsequently, a second form of MCH receptor, MCHR2, was identified (18, 272, 493, 645), and the SLC-1 is referred to as MCHR1. MCHR2 consists of 340 amino acids and shares ~38% identity with MCHR1. MCHR1 and MCHR2 are widely expressed in various regions of the brain.

B) MCH SIGNALING SYSTEM AND MELANOCYTES. In lower vertebrates, MCH induces melanosome aggregation within melanophores (whitening of the color). In mammals, MCH expression was detected in cultured human endothelial cells but not in human keratinocytes, melanocytes, and fibroblasts (285). MCHR1, but not MCHR2, expression was detected in human melanocytes and melanoma cells (285, 286, 650). Stimulation of cultured human melanocytes with MCH reduced the α -MSH-induced increase in cAMP production (285). Furthermore, the melanogenic actions of α -MSH were inhibited by MCH. MCHR1 has also been identified as a novel autoantigen in patients affected with vitiligo (353). Thus the MCH/MCHR1 system is functional in human skin and may regulate skin pigmentation through modifications of melanocortin signaling.

C. Cytokines, Growth Factors, and Receptors

1. IL-1, IL-6, and IFN- α and - γ and their receptors

Pigmentary changes are common features of postinflammatory and immunomodulatory events (513) and involve cytokines and growth factors. IL-1 is one of the most potent proinflammatory mediators and exists in two 17-kDa forms, IL-1 α and IL-1 β , synthesized as 31-kDa precursors in a range of cell types including epidermal keratinocytes and melanocytes (20, 764). IL-1 binds two specific receptors: a biologically active 80-kDa form called IL-1RI and an inert 60-kDa decoy protein, called IL-1RII. When IL-1 α and IL-1 β bind to IL-1RI, the IL-1 accessory protein joins to form the active complex that signals via NF κ B, JNK/AP-1, and p38 MAP kinase pathways (422). Similarly, IL-6 (formerly known as BSF-2 and IFN- β) is a pleiotropic cytokine that participates in immunomodulation, hematopoiesis, inflammation, and oncogenesis; it is produced by many cell types, including keratinocytes and fibroblasts, and stimulates proliferation in keratinocytes, being essential for wound healing (424). The receptor for IL-6, IL-6R, shares subunits with other

members of the cytokine superfamily of receptors. The IL-6R consists of two molecules, IL-6R α and gp130; it activates JAK tyrosinase kinases to induce the SHP-2/GAB-mediated ERK MAP kinase pathway and the STAT3-mediated pathway (276). Lastly, the interferons consist of a large family of antiviral peptides including IFN- α (12 subtypes), IFN- κ (keratinocyte specific), IFN- τ , and IFN- ω . These are classified as type I interferons with common three-dimensional structure and class of cell surface receptors. Type II interferon is represented by the acid labile IFN- γ , with its associated distinct cell surface receptors. IFN- γ is a 45-kDa homoglycoprotein with pleiotropic and primarily immunologic functions that is produced under pathological conditions, mostly by lymphocyte subpopulations. Biological function of IFN- γ is mediated by a receptor complex that signals via JAK1 and JAK2 members of the Janus family of protein tyrosine kinases (818).

A) IL-1, IL-6, AND IFN AND MELANOGENESIS. Melanocytes express and react to a myriad of cytokines and growth factors and thus can be viewed as an immunocompetent skin cell type with the potential to modulate its responses under different conditions. In fact, melanocytes have a dual function as participants and targets in the inflammatory response (440). Melanocyte phenotype is modulated in vitro by IL-1 α , IL-1 β , IL-6, TNF- α , and TNF- β , all of which markedly reduce the expression of melanocyte-specific antigen gp100, while enhancing the expression of VLA-2, ICAM-1, and HLA class I antigens, and inducing the expression of HLA-DR (379). IFN- γ also induces the expression of MHC II antigens in melanocytes, although not on all melanoma cell lines; some of these constitutively express the class II antigens. Nevertheless, IFN- γ appears to be unique in its ability to induce MHC II expression in melanocytes and melanoma (28, 292).

Melanocytes express and produce both IL-1 and IL-6 in culture (764, 801). IL-1 α and to a lesser extent IL-6 elicit a dose-dependent decrease in tyrosinase activity in normal human epidermal and uveal melanocytes in vitro (297, 379, 800). IL-1 β also inhibits tyrosinase activity (801). Both interleukins inhibited melanocyte proliferation, but in a noncytotoxic manner, as evidenced by the resumption of melanocyte proliferation after cessation of treatment. However, IL-1 α has also been reported to stimulate melanogenesis in organ-cultured guinea pig skin (449).

Similar variability of IL-1 effects on melanocytic cells has been reported on α -MSH binding in melanoma cells (59). When stimulatory for α -MSH binding, IL-1 treatment correlated with α -MSH-associated increase in both tyrosinase activity and melanin formation (192).

UVB radiation exposure stimulates the synthesis of both IL-1 and ET-1 in keratinocytes. However, while ET-1 stimulates melanogenesis and melanocyte proliferation (313), IL-1 α is reported to do the opposite (106, 315, 678,

800). Both IL-1 and ET-1 upregulate MC-1R activity and message, while TNF- α has the opposite effect. With regard to IL-6 inhibition of melanogenesis, this appears to be mediated by downregulation of the paired homeodomain factor Pax3 (343). Thus a sharp decrease in Mitf mRNA and gene promoter activity precedes the IL-6 associated reduction in melanogenesis. The Mitf promoter contains a *cis*-acting element that binds Pax3 and that mediates the IL6R/IL6. Pax3 expression declines after IL-6 treatment in B16/F10.9 melanoma cells.

Both IFN- α and IFN- β mRNA are expressed in normal cultured cutaneous melanocytes, but IFN- β mRNA, unlike IFN- α , is rarely expressed in melanoma cells (659). Expression of the proteins may be inducible, by polyinosinic polycytidylic acid (PPA), in the case of IFN- β in melanocytes and some melanoma cell lines. Notably, PPA also induced IFN- β mRNA and protein in some melanoma cells and inhibited the proliferation of melanoma cells, an effect blocked by anti-IFN- β antibody in cell lines that produced IFN- β . Skin hyperpigmentation has indeed been described during antiviral therapy with IFN- α (891), occurring on the skin and tongue in dark-skinned individuals. Increased melanogenic activity was also confirmed at the affected sites.

Intercellular adhesion molecule-1 (ICAM-1), an important regulator of immune cell-target interactions, is normally expressed at very low levels by normal cultured human melanocytes. Those levels can be significantly increased, in a physiologically relevant dose-dependent manner by IFN- γ , TNF- α , or IL-1 α (919). Indeed, mice overexpressing IFN- γ (under the influence of involucrin promoter) exhibit striking reduction in IFN- γ receptor expression but increased in ICAM-1 and MHC class II molecules expression on the surface of the transgenic keratinocytes. Transgenic mice exhibit hypopigmentation of the hair, due to a reduction in DOPA-positive melanocytes, as well as reddened skin, hair loss, and flaky skin lesions. It is of note that IFN- γ can upregulate the expression of some melanosomal antigens in melanoma cells, e.g., gp75, and that monoclonal antibody to gp75 can lead to tumor rejection in syngeneic mice (808). The overall inhibitory effect of INF- γ is documented by the observation that transgenic mice overexpressing INF- γ in epidermal keratinocytes develop hair hypopigmentation (100).

B) IL-1, IL-6, IFN, AND MELANOCYTE DISORDERS. IL-1 α obtained from stimulated human monocytes inhibits the proliferation of some human melanoma cells in culture and may even exhibit cytotoxic effects (535). Moreover, growth inhibition is reported to become irreversible with time, and cells are eventually lost from the cultures. However, IL-1 α antiproliferative effects in cultures of melanoma cells are variable, and sensitivity to growth inhibition by this cytokine may not correlate directly with the origin or biological behavior of the tumor lines (393).

IFN- α and IFN- γ that do not stimulate melanin synthesis when used alone exert differentiation influences on murine melanoma cells in the presence and absence of α -MSH (synergism) (345). In fact, the increase in pigment levels is significantly higher than in cells cultured with α -MSH only. Tyrosinase levels were unaffected, and thus stimulation of melanogenic activity is likely to occur via the activation of preexisting tyrosinase. The number of α -MSH receptors on IFN-treated cells also increased significantly, a mechanism that could participate in postinflammatory skin pigmentation (345).

In lentigo senilis-associated hyperpigmentation, ET-1 is increased in lesional, compared with perilesional, epidermis. The expression of TNF- α is also upregulated in lesional epidermis, whereas IL-1 α appears to be downregulated (342). IgG anti-melanocyte antibodies have been reported to stimulate IL-1 β and IFN- γ production in mononuclear cells in vitiligo, a phenomenon possibly linked to melanocyte destruction by monocytes (925). IL-6 production was also increased in vitiligo mononuclear cells, and ICAM-1 expression was enhanced on vitiligo melanocytes, perhaps increasing leukocyte-melanocyte attachment.

2. TNF- α , TNF- β (lymphotoxin- α), and TGF- β 1 and their receptors

TNF- α (formerly cachectin), its closely related cytokine TNF- β (now called lymphotoxin- α , LT- α), and TGF- β are involved in multiple cellular and inflammatory immune reactions through activation of corresponding receptors (144, 416, 814). TNFs and TGF- β s, along with a myriad of other cytokines (371), are modulated in the skin by diverse stimuli, most importantly UVR. As indicated elsewhere in this review, melanocytes are stimulated by some cytokines and growth factors (e.g., basic fibroblast growth factor, ET-1, hepatocyte growth factor, SCF) and inhibited by these and other cytokines

TNF- α and LT- α are encoded by genes that reside within the HLA class III region on chromosome 6 in humans. They bind to two receptors of the TNF receptor family, TNF-R1 and TNF-R2, and transduce signaling intracellularly via these receptors when expressed on the cell surface. TNF effects are blocked when these receptors are expressed as soluble "decoys" in body fluids. Both TNF- α and LT- α are trimeric proteins that exert their effects after receptor trimerization at the cell surface. While both TNF- α and LT- α can bind to both receptors with high affinity, soluble TNF- α may bind preferentially to TNF-R1. TNF-R1 is considered the most active and upon binding of TNF- α activates NF- κ B and AP-1 transcription to induce genes for proinflammatory and immunomodulatory molecules (814).

A) TNF- α , TGF- β 1, AND MELANOGENESIS. TNF- α is present in both the epidermis and dermis of normal skin (359).

TNF- α elicits a dose-dependent decrease in the activity of tyrosinase and inhibits melanocyte proliferation (800). While TNF- α also appears to be cytostatic, it is not cytotoxic, since melanocytes remain viable despite continuous treatments with the cytokine, with recovery of cell proliferation upon cessation of TNF- α treatment. TNF- α -associated inhibition of melanogenesis has also been reported in B16 melanoma (461), where TNF- α at nanomolar concentrations inhibits both tyrosine hydroxylase and dopa oxidase activities of tyrosinase, without affecting levels of tyrosinase-related protein 2/dopachrome tautomerase (TRP2/DCT).

TNF- α treatment of B16 mouse melanoma cells can also alter the expression of other melanosomal proteins and has been shown to reduce melanoma expression of gp87 (mouse ortholog of gp100 encoded by the silver locus) (462). It is of note that while gp87 protein expression was almost undetectable after TNF- α treatment, α -MSH blocked this TNF- α -associated reduction in protein expression without affecting gp87 mRNA levels. These results suggest the involvement of regulatory translational and/or posttranslational events. In B16 melanoma cells and melan-a melanocytes, TGF- β 1 also inhibits melanogenesis by decreasing tyrosinase and TRP-1 levels, although again no effect was observed on TRP-2 activity. While TGF- β 1 downregulates tyrosinase by decreasing both gene expression and the intracellular half-life of the enzyme, the cytokine does not appear to block tyrosinase stimulation by α -MSH. Moreover, as treatment with TGF- β 1 does not appear to alter melanosome number, the inhibitor effect of TGF- β 1 may reside at the rate-limiting step of the melanogenic pathway.

Treatment of cells with TGF- β 1, however, lowered the percentage of fully mature stage IV melanosomes and resulted in the accumulation of incompletely melanized melanosomes, inhibition of total melanin formation, and a hypopigmenting effect (460). However, both TGF- β 1 and TNF- α only slightly diminish MC1 receptor gene expression and have no effect on the intracellular levels of cAMP, or even the α -MSH-dependent rise in cAMP levels. Indeed, there is no evidence that TGF- β 1 or TNF- α block the response to α -MSH. Thus these effectors are likely to operate via α -MSH-independent routes, and the overall balance may dictate phenotypic outcome (463). Contribution to the overall hypopigmentary effect of both TNF- α and TGF- β 1 may involve a reduction in the expression of gp87, although, unlike TNF- α , TGF- β 1 does not affect the expression of this melanosomal protein (462). Both TGF- β and TNF- α exhibit variable antiproliferative effects on melanoma cell lines that correlate positively with their stimulation of collagenase secretion. Notably, a TNF- α -associated increase in NF κ B levels is seen in the apoptosis-sensitive melanocyte lines; the TNF- α -induced sensitivity to apoptosis correlated with low basal pigment lev-

els, and resistant cells were more heavily pigmented (696).

B) TNF- α , LT- α , AND TGF- β IN MELANOCYTE DISORDERS. A major limitation in the clinical use of TNF has been severe dose-limiting toxicity when administered systemically. However, when TNF- α is administered at low doses with melphalan, it reportedly exhibits significant antitumor activity (639). There is also some evidence that TNF- α can downregulate the vascular epidermal growth factor receptor and fetal liver kinase-1 (Flk-1) on endothelium in a human melanoma xenograft model (479). This may explain the apparently selective targeting of tumor vasculature, and the sparing of injury to surrounding normal tissues. However, tumor sensitivity to TNF- α appears to be variable, and the release of endothelial-monocyte-activating polypeptide II (EMAPII) may render the tumor-associated vasculature more sensitive to TNF- α . Indeed, if EMAPII is constitutively overexpressed in TNF- α -resistant human melanoma cells, increased tumor TNF- α sensitivity can be observed in vivo (907).

Pretreatment of some melanoma lines with inhibitors of NF κ B activation can markedly increase apoptosis in lines expressing death receptors for TNF- α -related apoptosis-inducing ligand (TRAIL). Thus activation of NF κ B by TRAIL may play an important role in resistance of melanoma cells to TRAIL-induced apoptosis. Treatment of both normal melanocytes and melanoma cells in vitro with TNF- α has been reported to upregulate the expression of ICAM-1 (362, 862). The high concentrations of ICAM-1 in sera of patients with metastatic melanoma have been shown to correlate with raised serum concentrations of TNF-R1 and TNF-R2 (362, 862).

In addition to TNF- α , human melanoma cell lines also express LT, where it appears to be constitutively expressed and characterized by the presence of a spliced and full-unspliced LT mRNA (478). Mice deficient in LT- α exhibit enhanced growth of syngeneic B16F10 melanoma cells compared with wild-type littermates, and metastases to lung were enhanced in the LT- α ^{-/-} mice. The principal immune deficiency associated with lack of LT- α appeared to be an impairment in the recruitment of NK cells to lung and liver, despite their normal total numbers (320). Overall, genetic variation in either TNF- α or LT- α production is nevertheless unlikely to play a major role in the clinical course of melanoma (294).

D. Other Negative Regulators of Melanogenesis

Vitamin E (α -tocopherol) can act as a potent inhibitor of melanogenesis (310). This effect is connected with inhibition of tyrosinase activity via posttranslational mechanism (193) and inhibition of active oxygen species-induced DNA damage (310). Ceramide-2, which belongs to a novel class of lipid second messengers, also inhibits

melanogenesis in human melanocytes through stimulation of extracellular signal-regulated protein kinase (ERK) and Akt/protein kinase B (360). Zinc α_2 -glycoprotein is produced locally by keratinocytes, and it inhibits melanogenesis in normal and malignant melanocytes (251).

A potential role for thyroid hormones in melanin pigmentation was analyzed *in vitro* using the B16 melanoma model (365, 768, 769). These studies demonstrated that triiodothyronine (T_3) but not thyroxine (T_4) inhibited both basal tyrosinase activity and melanin synthesis acting at the transcriptional level. Furthermore, T_3 inhibited imidazole-stimulated tyrosinase gene expression and activity in B16 melanoma cells. However, further studies are necessary to define pigmentary effects of thyroid hormones, since Graves' disease can be associated with generalized urticaria, alopecia areata, vitiligo, and generalized hyperpigmentation (759). Nevertheless, local autocrine mechanisms of action can be envisioned, since molecular elements of pituitary-thyroid axis were detected in the mammalian skin (761).

E. Summary

Therefore, suppression or inhibition of melanogenesis is difficult to demonstrate as a primary effect and requires most often proof of antagonism with stimulating agents. It is nevertheless the predominant influence of the agouti protein that makes it stand as a significant player in the regulation of rodent hair pigmentation. In fact, the agouti mutations powerfully underline the importance of its melanocortin receptor target. However, such a prominent role of agouti protein cannot be assigned to human pigmentation.

VI. MISCELLANEOUS REGULATION OF MELANOGENESIS BY NUCLEAR RECEPTORS AND THEIR LIGANDS

A. Glucocorticoids and Their Receptors

1. Glucocorticoid function and signaling in skin

The genomic glucocorticoid receptor (GR), the type II corticosteroid receptor, is a member of the nuclear receptor superfamily. However, glucocorticoids can also act through specific receptors at the membrane to exert effects within seconds to a few minutes, i.e., nongenomic effects (69). Skin cells, at least malignant melanocytes, may be able to synthesize corticosterone from progesterone or deoxycorticosterone to yield 11-deoxycorticosterone, corticosterone, and 18-hydroxydeoxycorticosterone (728). Cultured human epidermal keratinocytes, fibroblasts, and whole skin biopsies contain cytosolic proteins

that bind corticoids with high affinity (526, 589). Down-regulation of GR receptor expression in these cells has been noted after dexamethasone treatment (526). GR distribution in skin is heterogeneous, with the strongest expression in basal and isolated suprabasal keratinocytes and Langerhans cells. Only weak expression was detected in the differentiated layers of the epidermis.

2. Glucocorticoids and melanocyte biology

Both inhibition and stimulation of melanin synthesis were reported after glucocorticoid treatment. Thus glucocorticoid inhibition of melanogenesis via action on tyrosinase was noted in black guinea pig skin (24) and in the C57BL/6 mouse, where dexamethasone treatment induced catagen development and termination of anagen-associated melanogenesis (169). The latter effect was connected with a decrease of tyrosinase and DCT activities, attenuation of tyrosinase gene expression and protein production, as well as inhibition of MC1 receptor and POMC genes expression (169). It has been suggested that dexamethasone inhibited melanogenesis indirectly, for example, through attenuation of MSH receptor signal system (762).

Glucocorticoids may also be involved in melanocyte development and differentiation. Thus hydrocortisone inhibits the proliferation of mouse epidermal melanoblasts inducing instead the proliferating cells to differentiate into melanocytes. These hydrocortisone effects were seen only when pigment cells were cultured in the presence of keratinocytes, and not in medium conditioned with keratinocytes or their extracts (278). The synthetic glucocorticoid triamcinolone acetonide has been reported to inhibit growth in the GR-expressing mouse melanoma cell lines B16/F10 and B16/C3 (623). Interestingly, inhibition of B16 cell growth by glucocorticoids may occur only *in vivo* (in established tumors and transplants) and not *in vitro* (134). As regards effects on pigmentation, dexamethasone treatment of B16 melanoma cells results in a dose-dependent increase in melanin content (319), a phenotypic effect that correlates with increased expression of tyrosinase mRNA. Moreover, dexamethasone was noted to antagonize the 12-*O*-tetradecanoylphorbol 13-acetate (TPA)-associated decrease in tyrosinase mRNA level, suggesting that glucocorticoid regulation of tyrosinase activity is exerted at a transcriptional level. All steroids, dexamethasone, hydrocortisone acetate, and prednisolone, produce significant inhibition of B16 melanoma growth as assessed by mean tumor diameter and weight (but not by effect on pulmonary metastases).

The GR is expressed in the majority of human melanoma tumors, with higher expression levels in metastasis to lymph nodes and soft tissue compared with primary tumor. The expression of GR also increased in parallel with tumor invasion and thickness levels. Notably, pa-

tients with GR-negative melanomas tend to have a longer survival than those with GR-positive tumors. As already mentioned, glucocorticoid treatment inhibits the growth of GR-expressing human melanoma cells in culture (150), and triamcinolone increases melanogenesis in the human melanoma cell line NEL, by increasing tyrosinase activity and DOPA incorporation into melanin. Triamcinolone-treated NEL cells showed no changes in cAMP levels, whereas actinomycin prevented the increase in tyrosinase activity. Glucocorticoids also enhance the killing effect of photodynamic therapy combined with a hematoporphyrin derivative in B16 melanoma cells engrafted in a transplantable mouse tumor model (133).

B. Retinoids and Their Receptors

1. Retinoid function and signaling

Retinoids represent a group of natural and synthetic analogs of vitamin A or all-*trans*-retinol, which can bind and activate nuclear retinoid receptors. All-*trans*-retinoic acid is biologically the most active retinoid (346), with the skin being one of its production sites. The cellular retinoic acid binding proteins (CRABPs) can regulate retinoic acid action by preventing binding to nuclear retinoid receptors. When applied to human skin, all-*trans*-retinoic acid can be metabolized to the less-active 4-hydroxyretinoic acid (152). All-*trans*-retinoic acid binds and activates members of the retinoic acid receptor family (RAR- α , - β , - γ), while 9-*cis*-retinoic acid activates mainly the retinoid X receptor family (RXR - α , - β , - γ), but also RARs (453). These receptors usually pair-up and form RAR/RXR heterodimers that bind specific DNA sequences, the retinoid responsive elements (RARE or RXRE). Human epidermis contains up to five times more RXR protein (90% RXR- α) than RAR (179).

2. Retinoids and melanocyte biology

Retinoic acid can induce, in a developmentally restricted manner, differentiation of neural crest-derived cells (17, 154). In general, retinoic acid appears to influence, in a concentration-dependent manner, cell lineage fate decisions in neural crest-derived cells to favor catecholaminergic over melanocytic cells (17, 154), which suggest antipigmentary action. However, retinoic acid (at 100 nM) can terminally differentiate melanocyte progenitors (propigmentary effect) (154). This suggests that retinoic acid appears to be more potent as inducer of melanocyte maturation than development; it can thus promote basal levels of melanogenesis (i.e., differentiation) in melanoma cells (436). In humans with different basal pigment levels, retinoic acid can induce tyrosinase activity in white skin, but not in black skin (812).

Retinoic acid can inhibit melanoma and melanocyte proliferation (185, 436), although with considerable vari-

ability in the response across melanoma cell lines (159, 289). Both all-*trans*-retinoic acid and 9-*cis*-retinoic acid induce growth arrest and differentiation of S91 melanoma cells (776). Induction of differentiation is preceded by increased expression and activity of PKC- α (637). Melanoma clones overexpressing PKC- α exhibit reduced doubling times, diminished anchorage-independent growth, and increased melanin production, similar to the phenotypic changes induced by retinoic acid treatment in control cells (235). A role for PKC- α in the retinoic acid-induced melanoma differentiation is supported by the observation that retinoic acid action is antagonized by the PKC inhibitor TPA. The latter is commonly used in melanocyte culture systems to stimulate melanocyte growth and differentiation (162). Retinoic acid also increases AP-1 activity in some melanomas. The mechanism for the retinoic acid-induced cell cycle arrest of melanomas is not known (509). Differences in retinoid metabolism between melanocytes and melanoma include increases in the former in endogenous retinol and in [3 H]retinoic acid production from [3 H]retinal (631). Retinoic acid stimulates α -MSH receptor expression in S91 melanoma cells (108) and upregulates pigmentation in B16 melanoma cells by increasing α -MSH receptor expression (637).

Some reports have presented results discrepant with above, e.g., that retinoic acid inhibited the melanogenetic response to α -MSH or L-tyrosine (540, 541) or that it blocked imidazole-induced tyrosinase expression in B16 melanoma cells (770). Retinoic acid may have also inhibited UVB-induced melanogenesis in S91 melanoma cells and normal neonatal melanocytes through inhibition of tyrosinase and TYRP1 synthesis (627). Studies examining the efficacy of topical tretinoin on photoaging show limited reduction in epidermal melanin on actinic lentigines and mottled hyperpigmentation (52, 232, 882). Topical tretinoin also lightens postinflammatory hyperpigmentation and may even partially lighten normal skin in black individuals (86). While retinoic acid does not appear to significantly alter melanogenesis of cultured normal human melanocytes, it can alter cell shape, suggesting that retinoic acid may act on cytoskeleton proteins (397, 543). More recent contradictory data on retinoic acid effects on melanocytes (924) leave unclear its precise contribution to bleaching treatments (364).

C. Summary

Therefore, the effect of glucocorticoids and retinoids is more selective on differentiation than pigmentary activity. Further insight into the chemistry of these factors and their receptors may prove fruitful in the management of pigmentary disorders including melanoma.

VII. FUNCTIONAL REGULATION OF FOLLICULAR (HAIR) AND EPIDERMAL MELANIN UNITS

A. The Epidermal Melanin Unit

1. Development of cutaneous pigmentary units

Cutaneous melanocytes originate in the neural crest, where the emergence of a committed melanocyte lineage cells appears to be determined mainly by MITF, fibroblast growth factor 2, and ET-3 amongst others (155). Melanocyte precursors, melanoblasts, migrate from the dorsal portion of the closing neural tube (609) and move dorso-laterally to eventually populate, nonrandomly, the basal layer of the epidermis and the hair follicle. It appears that human melanocytes enter the dermis and are already present in the epidermis earlier than 7 wk estimated gestational age, at 2 wk before hair morphogenesis (283). Recently, it has been shown that keratinocyte-derived hepatocyte growth factor may be involved in this dermal localization of melanocytes by downregulation of E-cadherin in melanoblasts (381).

Melanocyte precursors experience changing micro-environments during their migration from the neural crest, through the dermis to the epidermis, and to their final location within the growing hair follicle (see below). There are at least 150 loci that affect coat color (Mouse Genome Database). Primary among these are mutations in the receptor tyrosine kinase *c-Kit* [mapped to the white spotting (*W*) locus in mice] and its cognate ligand, *SCF*. Another signaling pair that appears to be essential for the development of neural crest-derived melanocytes is ET-3 with its receptor B (*Ednrb*) (155, 394). ET-3 itself is highly mitogenic for undifferentiated neural crest cells and results in the preferential expansion of melanocytes (34).

The temporal and spatial regulation of adhesive properties of melanoblasts and melanocytes are also likely to affect migration from the neural crest to the skin. Movement of these cells, guided by their migration substrate, involves both integrins (577) and extracellular matrix molecules (266). The expression of cadherins also changes along the path of migrating melanoblasts/melanocytes. E-cadherin expression is restricted to the epidermis while P-cadherin expression is observed in the hair bulb matrix (275). Thus the migratory pathway taken by melanocytes en route to the skin compartments during development is likely to involve multiple signaling events, both permissive and nonpermissive.

2. Melanocyte-keratinocyte interactions

Melanocytes reside, as scattered dendritic cells, in the basal layer of the human epidermis. Considerable interindividual and intraindividual variations in melano-

cyte population densities exist, with more than twice as many melanocytes located in head and forearm skin compared with elsewhere on the body, regardless of racial origin (182). Thus the main contributor to racial differences in skin pigmentation is cellular activity rather than absolute melanocyte numbers (803). The issue of the intrinsic proliferative potential of epidermal melanocytes has not yet been convincingly settled. An increase in melanogenically active melanocytes is indeed seen after UV irradiation (632), but it is not clear if these additional cells are truly derived from division of already functioning melanocytes. In contrast, melanocytes in the hair follicle divide during the hair cycle. Melanocyte loss (mostly probably via apoptosis) occurs in both sun-exposed and covered skin with an ~10% reduction per decade after 30 yr of age until 80 yr, followed by more dramatic cell loss thereafter (512). This age-related reduction is more marked in number of epidermal than hair follicle melanocytes, but the effect on overall loss of pigmentation is subtler.

Cutaneous melanocytes, like other neural-crest derived cells, exist in the context of supporting cells. In the skin, this "supporting" role is provided by the keratinocyte with which melanocytes forms the epidermal-melanin unit. These structural and functional cellular units exhibit complex, life-long, cellular interactions originally laid down during embryonic life. Each single, well-differentiated, melanocyte interacts with a remarkably consistent complement of ~36 viable keratinocytes at various stages of progression to the upper cornified layer of the epidermis (180). The "blueprint" for epidermal-melanin unit function appears to be finely drawn, with a mosaic of discrete unit areas that are remarkably consistent between races, but variable at the regional level, e.g., the darker skin in the folded areas of axillae and perineum. When differentiated, melanocytes assume the highly dendritic phenotype that facilitates closer contact with keratinocytes. While the keratinocyte partners are all linked via desmosomal intercellular junctions, melanocytes remain as singly scattered cells with the degree of contact with keratinocytes being determined by the level of ramification/aborization of their dendrites. Of note, the regulatory role exercised by keratinocytes is restored in melanoma cells if expression of E-cadherin is induced permitting their adhesion to keratinocytes (295). The obvious interaction between melanocytes and keratinocytes is the transfer of melanin granules; nevertheless, melanocyte growth, dendricity, spreading, cell-cell contacts, and melanization can all be regulated by keratinocyte-secreted factors (819). Keratinocytes in coculture with melanocytes can also suppress melanogenic proteins such as the TyrP1, an important consideration for grafting in patients with depigmenting disorders (583).

3. Melanin transfer to keratinocytes

Transfer of melanin to keratinocytes in the epidermis or cortical and medullary keratinocytes of the growing hair shaft is presumed to involve the same mechanism(s). At least four theories have been proposed to be involved for this "whole organelle donation" to another cell, a unique biological process: 1) the "cytophagic" theory, where the keratinocyte, as active partner, phagocytoses the tips of dendrites that contain stage IV mature melanosomes (203); 2) the "discharge" theory, where mature melanosomes are released into the intercellular space to be internalized by adjacent keratinocytes; 3) the "fusion" theory, where mature melanosomes pass from melanocyte to keratinocyte via fusion of their respective plasma membranes (529); and 4) the "cytokrine" theory, whereby melanocytes would inject melanin into recipient keratinocytes (465). Once transferred into epidermal keratinocytes, melanin forms pigment caps over the keratinocyte nuclei. Epidermal melanocytes rarely collect mature melanosomes intracytoplasmically; instead, it translocates them to keratinocytes. This is in contrast to bulbar follicular melanocytes, which are commonly heavily laden with fully mature stage IV melanosomes.

Studies using time-lapse digital video imaging and electron microscopy have shown filopodia from melanocyte dendrites as the conduits for melanosome transfer to keratinocytes (686). When melanocytes were cocultured with keratinocytes, a highly dendritic phenotype was induced characterized by extensive contacts between melanocytes and keratinocytes through filopodia, many of which contained melanosomes. Melanocyte dendricity is also likely to be important in melanin transfer and the dendrites of melanotic bulbar melanocytes in some mouse mutants, e.g., dilute (*d*) or pink-eye dilute (*p*) are abnormally short. Notably, myosin V (encoded by the dilute gene) has also been proposed as the molecular motor involved in dendrite outgrowth in mammalian melanocytes (398, 853, 881); mutations at that locus are associated with dilution of hair color (257). Moreover, phagocytosis of melanosomes by keratinocytes is mediated via the activation of the protease-activated receptor 2 on keratinocytes, and inhibitors of PAR2 retard melanosome transfer (690).

B. Regulation of Hair Cycle-Coupled Follicular Melanogenesis

1. Development of hair follicle

By 7 wk estimated gestation age, melanocytes are already present in the human epidermis and remain there until hair morphogenesis begins, ~2 wk later (283). With the onset of hair follicle morphogenesis, some melanoblasts leave the epidermis and distribute randomly as

dopa-positive and dopa-negative cells in the forming hair follicle and occasionally in the sebaceous glands (321). Melanogenic melanocytes can be detected in all stages of human hair morphogenesis from the hair germ stage onwards, usually confined to the peripheral regions of the hair follicle (259). Once the hair fiber has formed, melanocytes are noted in large numbers near the basal lamina around the apex of the follicular papilla. While melanocyte mitosis is observed in the human epidermis at 14 wk estimated gestation age, mitosis of pigment cells is rarely observed in the hair follicles themselves. Melanocytes undergoing apoptosis are occasionally seen in the follicular tract (259).

During embryonic life murine follicular melanocytes do undergo apoptosis after injection of a Kit blocking antibody (ACK2) (320). Postnatally *c-kit* is also required for melanocyte activation during the hair growth cycle, although the melanocyte stem cell compartment appears to exhibit SCF/*c-kit* independence (71). Melanoblasts express *c-kit* as a prerequisite for migration into the SCF-supplying hair follicle epithelium. While differentiated *c-kit*-positive melanocytes target the bulb, *c-kit*-negative melanoblasts invade the outer root sheath and bulge in fully developed hair follicles (578).

2. Adult hair follicle

Melanocytes in the fully developed anagen follicle can be assigned to four distinct anatomic compartments on the basis of staining patterns with DOPA, Masson silver, toluidine blue, and thionine. In the mature hair follicle, dopa-positive melanotic melanocytes are readily detectable in outer root sheath of the infundibulum and around the upper dermal papilla. Dopa-negative amelanotic melanocytes are detectable in the mid to lower outer root sheath. The fourth sector demarcates the amelanotic dopa-negative melanocytes distributed in the periphery of the bulb and most proximal matrix. Immature melanocytes have been clearly demonstrated in the adult hair follicle (287, 828). Immunostaining with NK1-beteb, a monoclonal antibody that detects a (pre)melanosome glycoprotein (859), detects all dopa-positive cells but also highlights some dopa-negative melanocytes of the mid outer root sheath (287). While the dopa-oxidase activity of tyrosinase is not detectable in amelanotic hair follicle melanocytes, the protein itself may be detected in some of these cells (546). Similarly, while Kit and Bcl-2 reactive melanocytes are present in this hair follicle compartment (231), these amelanotic melanocytes do not express the melanogenic enzymes TRP-1 and TRP-2 (287).

The hair bulb, however, is the only site of pigment production for the hair shaft and contains both highly melanogenic melanocytes and a minor subpopulation of poorly differentiated, NK1-beteb⁺, pigment cells (828, 829). It has been speculated that amelanotic hair bulb

melanocytes may represent a pool of “transient” melanocytes that migrate from precursor melanocytes stores in the upper outer root sheath (783, 828, 829). The restriction of melanogenically active melanocytes to the upper hair matrix of the anagen hair follicle, just below the precortical keratinocyte population, correlates with the observation that melanin is transferred during anagen to the hair shaft cortex, less so to the medulla, and, very rarely, the hair cuticle. Melanogenically active melanocytes in the hair bulb form functional units with neighboring immature precortical keratinocytes that receive their melanized secretory granules and ultimately form the pigmented hair shaft. Bulbar melanocytes also interact closely with the dermal papilla as evidenced by their direct contact during the anagen with the thin and permeable basal lamina separating from the mesenchymal dermal papilla.

3. Follicular melanin unit

While follicular melanocytes are derived from epidermal melanocytes during hair follicle morphogenesis, these pigment cell subpopulations diverge in many important ways as they distribute to their respective distinct compartments. The “follicular-melanin unit” resides in the “immune privileged” proximal hair bulb (57, 121, 886) and consists of one melanocyte for every five keratinocytes in the hair bulb as a whole; the ratio is 1:1 in the basal epithelial layer next to the dermal papilla (831). Hair bulb melanogenic melanocytes differ from epidermal melanocytes in being larger, with longer and more extensive dendrites, containing more developed Golgi and rough endoplasmic reticulum, and producing two- to fourfold larger melanosomes (39). While melanin degrades almost completely in the differentiating layers of the epidermis, eumelanin granules transferred into hair cortical keratinocytes remain minimally digested (39). Thus eumelanin white individuals may have dark black hair but very fair skin and blue eyes.

Activity of the hair bulb melanocyte is under cyclical control and melanogenesis is tightly coupled to the hair growth cycle (738), in contrast to epidermal melanogenesis, which appears to be continuous (517). Hair grows cyclically through a finite period of hair shaft formation (anagen; ~3–5 yr in human scalp), a brief regression phase resulting in the apoptosis-driven resorption of up to 70% of the hair follicle (catagen; ~3 wk in human scalp), and a relatively quiescent period (telogen; ~3 mo in human scalp) (112, 363). Even before catagen-associated structural changes, towards the end of anagen VI, the earliest signs of imminent hair follicle regression become apparent, e.g., retraction of melanocyte dendrites and attenuation of melanogenesis (744, 745). Keratinocyte proliferation, however, continues for some time, and most proximal telogen hair shaft remains unpigmented. The

melanogenically active melanocytes of the anagen phase are no longer detectable during catagen. The hair bulb melanocyte system has long been viewed as self-perpetuating whereby melanocytes involved in the pigmentation of one hair generation are also involved in the pigmentation of the next (794). However, melanocytes would need to survive/avoid the extensive apoptosis-driven regression of the hair bulb (426, 878). It now appears that “redifferentiating” melanocytes in early anagen are more likely to correspond to newly recruited immature melanocytes derived from a melanocyte reservoir (230) located in the upper, “permanent,” outer root sheath. This view is supported by the observation that immature melanocytes are located very close to the secondary epithelial germ of the telogen club (708) where they are commonly small, have high nuclear to cytoplasmic ratios, and inactive cytoplasm with very few organelles. In the C57BL/6 mouse model, many highly melanotic hair bulb melanocytes do not survive catagen (830).

The relatively quiescent telogen hair germ contains precursors for all the cell types that will make the fully developed anagen VI hair follicle. Melanin synthesis is not detected by histologic or histochemical examination in telogen hair follicles, but very low tyrosine hydroxylase activity of tyrosinase can be detected; this disappears on *days 1* and *2* after anagen induction (741). Undifferentiated melanocytes/melanoblasts of the telogen germ are stimulated at the start of anagen and respond by increasing their cell volume. This anagen-associated signal precludes the melanogenic stimulus delivered during anagen III and is followed by active melanogenesis and subsequent transfer of mature melanosomes into precortical keratinocytes. Melanocytes in the S phase of the cell cycle occur as early as anagen II, and significant proliferation is clearly apparent by anagen III (795). Mitosis is also observed in melanogenically active cells, indicating that melanocyte differentiation does not preclude mitotic activity. Ultrastructural changes in bulbar melanocytes that accompany anagen III to full anagen progression include 1) increased dendricity, 2) development of Golgi and rough endoplasmic reticulum, 3) increased size/number of melanosomes, and 4) transfer of mature melanosomes to precortical keratinocytes.

VIII. UNIFIED CONCEPT FOR THE TRANSCRIPTIONAL REGULATION OF MELANOGENESIS: A KEY ROLE FOR MICROPTALMIA-ASSOCIATED TRANSCRIPTION FACTOR

MITF plays a fundamental role in the regulation of mammalian pigmentation. This is evidenced by the genetically determined pigmentary disorders resulting from semidominant mutation at the *Mitf* (*Mi*) locus in mice

(647, 648, 701, 810, 918). The main phenotypic effects include loss of pigmentation, reduced eye size, early onset of deafness, lack of mast cells, and failure of secondary bone resorption. Dominant mutations at its human homolog MITF [Waardenburg syndrome type 2A (WS2A) and Tietz syndrome (TS)] are characterized by patchy depigmentation of hairs and skin, hearing loss, and heterochromia iridis in WS2A, while TS is characterized by generalized albinism, profound deafness, and hypoplasia of eyebrows. Thus clinical, genetic, and experimental observations clearly demonstrate that *Mitf*/MITF is essential for the development and function of melanocytes, retinal pigment epithelium (RPE), mast cells, and osteoclasts.

The MITF gene contains at least 13 exons, and at least 5 multiple alternative promoters and transcription initiation sites (701) (Fig. 11). There are at least five MITF isoforms (A, B, C, D, H, and M) that are products of alternative initiation of transcription driven by different promoters and process of alternative splicing (810). There are also three additional isoforms MITF-C, MITF-E, and MITF-MC, but the location of their first exon is unknown. All isoforms share the carboxy terminus (encoded by 8 downstream exons) containing a serine-rich region, bHLH-LZ structure, and transcriptional activation domain differing in the amino terminus. The amino terminus in the MITF-M isoform is encoded by the melanocyte-spe-

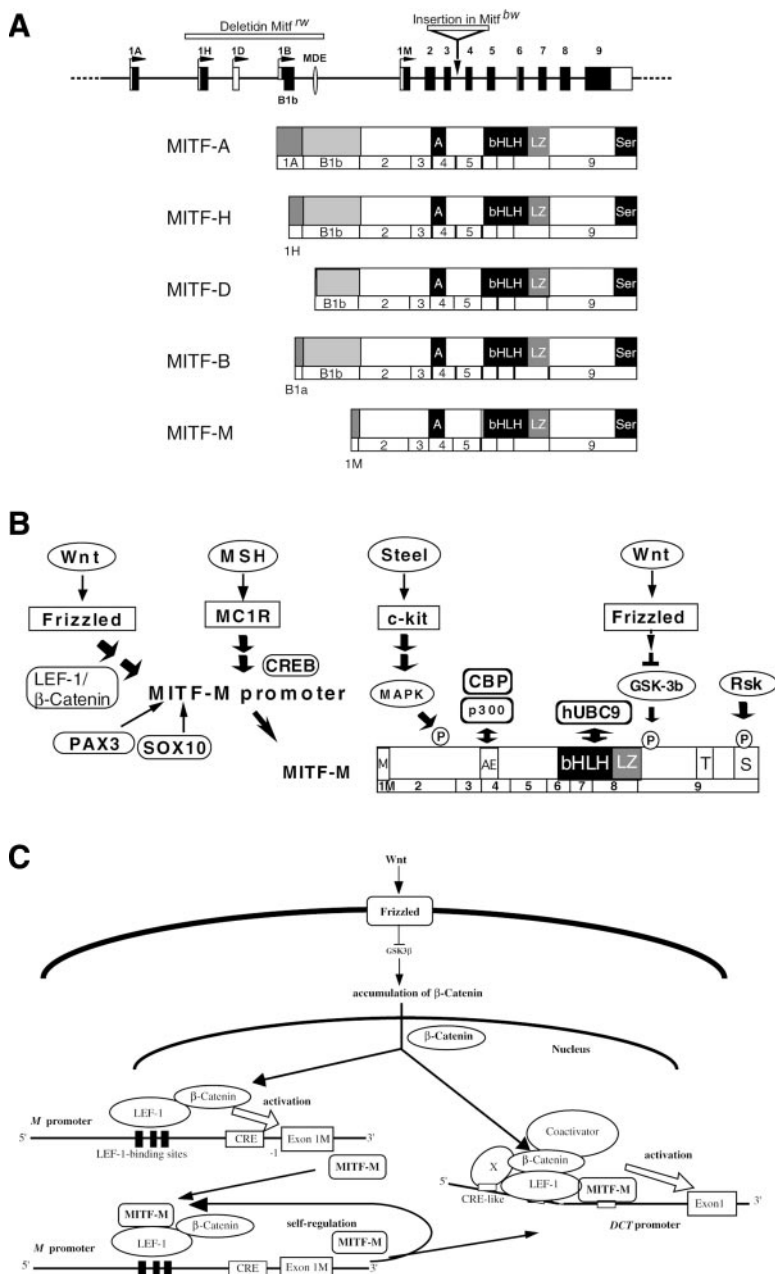

FIG. 11. MITF-M protein in the regulation of melanocyte activity. *A*: MITF gene structure. *B*: regulation of MITF-M. *C*: MITF-M associated transcriptional activity in the Wnt signaling pathway. [Modified from Saito et al. (648).]

cific exon 1 (exon 1M), and its expression is exclusive to the melanocyte lineage, because of its unique melanocyte-restricted promoter enhancer.

Selective requirement of *Mitf*-M for melanocyte development was verified by the molecular analysis of black-eyed white, *Mitf*^{mi-bw} mice (911), characterized by white coat color, deafness, and normally pigmented RPE without ocular abnormalities. The molecular lesion in *Mitf*^{mi-bw} mice is the insertion of an L1 retrotransposable element in the downstream intron (see Fig. 11), leading to complete repression of transcription from the M promoter.

The promoter region of MITF-M contains CREB, SOX10, PAX3, and LEF-1 binding sites that stimulate gene transcription by interacting with the corresponding regulatory factors and β -catenin (647, 648, 701, 810, 918) (Fig. 11). The predominant pathways driving the activity of this promoter are those activated by Wnt and MSH. Most recently, MITF-M distal enhancer (MDE) was identified 14.5 kb upstream from exon 1M that would act as an upstream *cis*-acting element required for efficient transcription of M promoter (Fig. 11). It contains two functional SOX10 binding sites, and its role in regulation of pigmentation is underlied by the phenotype of the homozygous red-eyed white *Mitf*^{mi-rw} mutant showing red eyes and white coat with some pigmented spots around the head and the tail.

WS is genetically heterogeneous and exhibits sensorineural hearing loss and abnormal pigmentation that are caused by melanocyte deficiency in the cochlea and skin. It is noteworthy that other subtypes of WS are associated with mutations in the genes coding for PAX3 and SOX10, both of which are involved in the transcriptional regulation of the MITF gene (701). PAX3, containing a paired homeodomain, is responsible for WS1 and WS3 (31, 290, 815–817). SOX10, containing a high-mobility group box as a DNA-binding motif, is responsible for Waardenburg-Hirschsprung syndrome, also known as WS4 (268, 584), which is characterized by aganglionic megacolon in addition to auditory-pigmentary abnormalities. Thus MITF, PAX3, and SOX10 constitute a regulatory network controlling melanocyte development.

MITF-M function is also regulated at the posttranslational level through phosphorylation at the serine residues and by interaction of MITF-M with CBP/p300 transcription coactivator complex, and with ubiquitin conjugating enzyme hUBC9 (Fig. 11). Phosphorylation of Ser-73 by MAP kinases activated by the Steel/*c*-Kit signaling pathway upregulates MITF-M functions, being further stimulated by interaction with CBP/p300 (Fig. 11). *c-kit* also phosphorylates MITF-M at Ser-409 through serine/threonine kinases (Rsk), resulting in short-lived activation followed by proteolytic destruction. Phosphorylation at position Ser-73 by MAP kinases also allows binding of hUBC9 and targeting for degradation. Glycogen synthase

kinase 3β (GSK- 3β) also phosphorylates MITF-M at Ser-298 (Fig. 11) (648). The latter is complicated in the way that GSK- 3β inhibits Wnt signaling (β -catenin) (889), and also is inhibited by the *c*-Kit signaling pathway through PI3P/AKT cascade (889). Thus regulation of MITF-M as well as of other MITF isoforms is complex and involves transcriptional and posttranslational mechanism activated by different signaling systems (Fig. 11), as well as degradation pathways necessary to provide tight homeostatic control of MITF-M in the melanocytes.

MITF-M is a target for Wnet (a cysteine rich glycoprotein important for neural crest cells development) through activation of its Frizzled receptor, inhibition of GSK- 3β , and stimulation of β -catenin accumulation (Fig. 11). β -catenin not only participates in stimulation of MITF-M promoter activity but also in stimulation of MRP gene transcription. MITF-M in cooperation with LEF-1 also stimulates its own transcription and that of tyrosinase-related genes (Fig. 11). Since the M promoter region does not contain M or E boxes, MITF-M acts as a cofactor for LEF-1.

MITF thus plays a fundamental role providing positive regulation of transcription of tyrosinase, TyrP1 and TyrP2 genes through interaction with M and E boxes, a prerequisite for production of melanin pigment. Furthermore, the promoter region of the MC1-R contains E-box sequences and binds MITF-M, thus stimulating the expression of both MRPs and MSH receptor (21). The latter suggests that MITF-M not only regulates production of melanogenic proteins at mRNA level, but also may regulate indirectly posttranscriptional and posttranslational steps of melanogenesis through MC1R. The hypothesis that MITF-M serves as a master regulator of the melanogenic apparatus is supported by the demonstration of actual melanogenesis after overexpression of this transcriptional factor in fibroblast. Finally, factors that stimulate melanogenesis induce MITF-M, while those inhibiting melanin synthesis inhibit MITF-M, with MITF-M being expressed in all normal melanocytes and the vast majority of melanoma cells. MITF-M can also produce sustained growth and survival of melanocytes through the upregulation of the major antiapoptotic agent *bcl2* (474). Therefore, MITF-M may act as a self-regulating switchboard for diverse pathways originating at the cell membrane or intracellular environment and regulating the activity of the melanogenic apparatus (Fig. 12).

IX. MELANOGENESIS AS MOLECULAR SENSOR AND TRANSDUCER OF ENVIRONMENTAL SIGNALS AND REGULATOR OF LOCAL HOMEOSTASIS

The type and concentration of cutaneous melanin pigment determines its critical functions in camouflage,

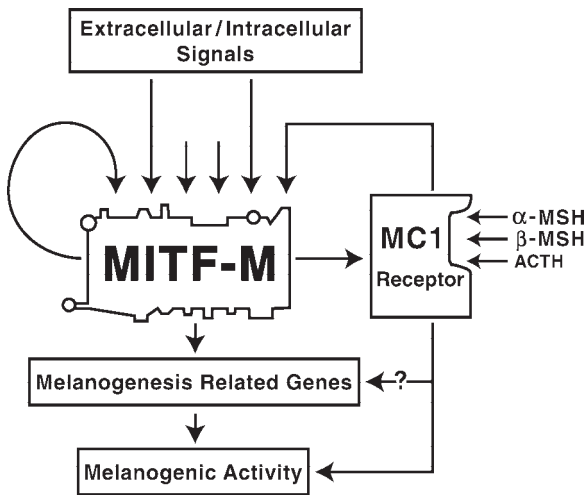

FIG. 12. MITF-M as molecular switchboard for melanogenic signals.

mimicry, social communication, and protection against the harmful effects of solar radiation. Epidemiological data show that highly pigmented skin in humans is associated with a severalfold decrease in the risk of skin cancer. The human skin pigmentary response to UV is biphasic with immediate skin darkening, predominantly seen with UVA, and delayed longer lasting response (tanning), predominantly induced by UVB (181, 213, 561). The immediate darkening effect is rapid (within minutes), and

transient (fades within hours). This response implies that the elements of melanogenic apparatus must act as unique molecular receptors of solar light energy, for rapid transduction into visible phenotypic effect (skin darkening) (747). The various physical properties of melanin (paramagnetic, oxidoreductive, ion exchange, optical, photoreactive, and electric) as well as the physicochemical nature of melanogenesis indicate that the light-induced changes must affect epidermal homeostasis through changes in the internal environment of cells bearing melanosomes, and through flux of ions or other bioactive molecules across gap junctions of the epidermis (Fig. 13). Light wavelength per se also affects melanogenesis. Thus UVA induces dark pigmentation predominantly in basal keratinocytes, and UVB induces melanin distribution throughout the epidermis, although the most energetic and mutagenic UVC has little or no pigmentary effect.

Melanosomes are metabolically active organelles that can, and do, affect the state and function of the host melanocyte or keratinocyte (746). This is related to their oxygen consumption that modifies the energy-yielding metabolism, alterations of the intracellular NAD/NADH and NADP/NADPH ratio or stimulation of the pentose phosphate shunt, the buffering of calcium and other ions, the reversible binding of bioregulatory compounds, internalization of toxic factors, and production of biologically active intermediates of melanogenesis (reviewed in Refs.

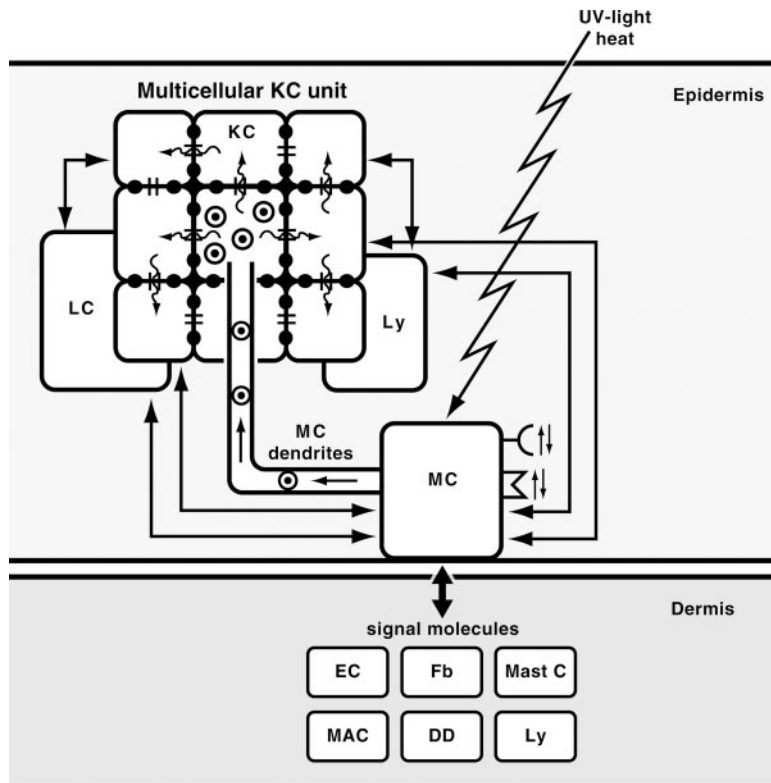

FIG. 13. Melanocytically active melanocyte as the sensor and computing cell regulating cutaneous homeostasis. [Modified from Slominski et al. (746).]

736, 739, 746). Thus melanosomes represent cell regulatory packages sent to neighboring keratinocytes to coordinate the response to signals that have activated melanocytes. Intermediates of melanogenesis, also released by melanocytes, may even affect the local immune system (743, 746). One intermediate, L-DOPA, serves in fact as a precursor to catecholamines (161). Thus after signals of varying natures are relayed to the melanogenic apparatus, they may trigger cascades of responses modifying local homeostasis. Systemic effects may also become evident as in the attenuation of the vitamin D₃ photosynthetic response after tanning, or in its strong dependence on racial pigmentation (468).

It must be emphasized that in addition to environmental physical signals, melanocytes are exposed to multiple chemical and biological signals generated within its vicinity, distally, or by nerve endings. Thus melanogenic responses can also be elicited by local stress within the epidermis. These melanogenesis-associated stress responses are likely addressed at counteracting environmental insults, and/or optimizing homeostatic adaptation mechanisms. Thus this system of multidirectional communications within the skin provides a new level for the local regulation of skin function in which melanogenic activity serves as a unique molecular sensor and transducer of noxious signals and as regulator of local homeostasis.

X. COMMENTS AND FUTURE DIRECTIONS

When considering the multiple functions of the melanogenic apparatus, it is understandable that myriad hormones and molecular factors would be involved in the regulation and "fine-tuning" of melanogenesis. Thus the complex regulatory control of the biosynthetic machinery involved in melanogenesis includes receptor-mediated pathways activated by hormones, neurotransmitters, cytokines, growth factors, and eicosanoids as well as receptor-independent mechanisms activated or modified by nutrients, micromolecules, microelements, pH, cations and anions concentrations, and the oxidoreductive potential in the physicochemical milieu. Soluble factors can reach their target (melanocyte) from circulation, from release by nerve endings, or from local production to act as positive or negative melanogenesis regulators.

The most important positive regulator is the MC1R, with its ligands melanocortins and ACTH. Other locally produced factors are represented by the endothelins, important stimulators of melanogenesis in melanocytes, and with a positive role in the embryonic development of pigmentation. A crucial role in embryonic development of the melanin pigmentation as well as in the formation of hair follicle pigmentary unit is the SCF with its *c-kit* receptor. Less significant, although still potent positive

regulators of cutaneous melanogenesis are components of the skin immune system such as histamine and eicosanoids; these are produced locally or delivered from systemic circulation. Miscellaneous participants in melanogenesis are β -endorphin, estrogens, androgens, vitamin D₃, and catecholamines. The nutritional factors L-phenylalanine, L-tyrosine, and L-DOPA are crucial for melanin synthesis with the last two amino acids acting as both substrates and positive (hormonelike) regulators in the conversion of L-tyrosine into the pigment melanin. Because the latter functions have only been documented in cultured cells, the general concept will require extensive *in vivo* testing.

The most important negative regulator of melanogenesis, which determines the type of melanin synthesized, is the locally produced ASP. ASP switches eu- to pheomelanogenesis and also inhibits the pathway by acting as antagonist to melanocortins (competitively and noncompetitively) through its binding to the same or separate sites on the MC1R. ASP is a significant player in the regulation of rodent hair pigmentation; however, such a prominent role as agouti protein cannot be assigned to human pigmentation. Negative regulation is also provided by the cytokines IL-1, IL-6, INF- γ , and TNF- α , produced by the skin immune system, and by growth factor TGF- β . Melatonin is a potent lightening factor in the skin of lower vertebrates that can inhibit hair pigmentation in furry animals, although its function on human pigmentation is still unclear. There are indications that dopamine, ACh, and possibly serotonin can inhibit melanin pigmentation. Among factors with mixed functions, i.e., both positive and negative regulators of melanogenesis, are glucocorticoids and retinoids. Interestingly, a dual effect for ET-1 on melanin synthesis in cell culture has also been described whereby it stimulates melanogenesis at low (physiological) concentrations and inhibits the process at high (pharmacological) concentrations (515).

The most important biochemical pathways regulating melanogenesis are activated by cAMP, although PKC also plays a regulatory role. These pathways act at transcriptional, translational, and posttranslational levels. Among the transcriptional regulators, the most important is MITF that acts as the central switchboard for the routing of the various signals involved in the expression of melanogenesis-related genes, thus defining at any given time the prevailing melanogenic algorithm.

It is worth emphasizing that melanogenesis is regulated directly (through receptor-mediated or metabolic action on melanocytes) or indirectly through stimulation of other cellular targets, which in turn release biologic regulators or simply change the chemical environment of melanocytes. Furthermore, instant receptiveness selectivity to pro- or antimelanogenic signals of melanocytes could also be modulated by modification of receptor expression or signal transduction or transcriptional activity;

it can also be tuned-up by bioregulatory factors that alone would have no activity on melanogenesis. Indeed, sometime conflicting results reported in the literature may have been determined by the environmental context of the particular bioregulator action. These complex interactions are characteristically expressed in the function of the hair pigmentary unit where melanogenesis is coupled to the anagen phase of hair cycle. It is currently assumed that anagen coupled melanogenesis is primarily driven by the local circuitry regulating hair growth interacting at multiple points with follicular melanogenesis.

In summary, the multidirectional nature and heterogeneous character of the melanogenesis-modifying agents clearly define a highly complex regulatory system. It is also clear that the controlling factors are not arranged in simple linear sequences. Instead, as presented in this review, melanogenesis regulators and their modifiers interact in a model best described as a multidimensional network, with extensive overlapping and diversity of factors acting in a nonrandom fashion determined by the biochemical-physical context. Precise definition of hierarchical positions in this model will help clarify existing gaps and discrepancies on the current information on mammalian melanin pigmentation.

We thank Dr. V. Hearing for providing Figures 4 and 5 and valuable comments; Dr. B. Zbytek for Figure 10; Drs. B. Gilchrist, M. Holick, J. Pawelek, P. Plonka, T. Sarna, and K. Shallreuter for valuable comments; T. Higgins for preparation of Figures 3K, 7-9, 11, and 12; and C. Crawford for excellent secretarial work.

This work was supported in part by National Institute of Arthritis and Musculoskeletal and Skin Diseases Grant AS-47079-01 and grants from the Center of Excellence in Genomics and Bioinformatics and Center of Excellence in Connective Tissue Diseases (to A. Slominski).

Address for reprint requests and other correspondence: A. Slominski, Dept. of Pathology, Suite 599, Univ. of Tennessee Health Science Center, 930 Madison Ave., Memphis, TN 38163 (E-Mail: aslominski@utm.edu).

REFERENCES

1. **Aaronson DW.** Comparative efficacy of H1 antihistamines. *Ann Allergy* 67: 541-547, 1991.
2. **Abdel-Malek Z, Swope VB, Suzuki I, Akcali C, Harriger MD, Boyce ST, Urabe K, and Hearing VJ.** Mitogenic and melanogenic stimulation of normal human melanocytes by melanotropic peptides. *Proc Natl Acad Sci USA* 92: 1789-1793, 1995.
3. **Abdel-Malek ZA, Ross R, Trinkle L, Swope V, Pike JW, and Nordlund JJ.** Hormonal effects of vitamin D₃ on epidermal melanocytes. *J Cell Physiol* 136: 273-280, 1988.
4. **Abdel-Malek ZA, Swope VB, Amornsiripanitch N, and Nordlund JJ.** In vitro modulation of proliferation and melanization of S91 melanoma cells by prostaglandins. *Cancer Res* 47: 3141-3146, 1987.
5. **Adur J, Takizawa S, Quan J, Uchida T, and Saida K.** Increased gene expression and production of murine endothelin receptors after birth. *Biochem Biophys Res Commun* 305: 700-706, 2003.
6. **Agarwala SS.** New applications of cancer immunotherapy. *Semin Oncol* 29: 1-4, 2002.
7. **Agin PP, Sayre RM, and Pawelek JM.** Phosphorylated mixed isomers of L-dopa increase melanin content in skins of Skh-2 pigmented hairless mice. *Pigment Cell Res* 1: 137-142, 1987.
8. **Ahene AB, Saxena S, and Nacht S.** Photoprotection of solubilized and microdispersed melanin particles. In: *Melanin, Its Role in Human Photoprotection*, edited by Zeise L, Chedekel M, and Fitzpatrick TB. Overland Park, KS: Valendmar, 1995, p. 255-269.
9. **Aime S, Fasano M, Bergamasco B, Lopiano L, and Valente G.** Evidence for a glycidic-libidic matrix in human neuromelanin, potentially responsible for the enhanced iron sequestering ability of substantia nigra. *J Neurochem* 62: 369-371, 1994.
10. **Allan AE, Archambault M, Messina E, and Gilchrist BA.** Topically applied diacylglycerols increase pigmentation in guinea pig skin. *J Invest Dermatol* 105: 687-692, 1995.
11. **Alesci S and Bornstein SR.** Neuroimmunoregulation of androgens in the adrenal gland and the skin. *Horm Res* 54: 281-286, 2000.
12. **Al Rustom K, Gerard J, and Pierard GE.** Extrapituitary neuroendocrine melanoderma. Unique association of extensive melanoderma with macromelanosomes and extrapituitary secretion of a high molecular weight neuropeptide related to pro-opiomelanocortin. *Dermatologica* 173: 157-162, 1986.
13. **Amae S, Yasumoto K, Takeda K, Udono T, Takahashi K, and Shibahara S.** Identification of a composite enhancer of the human tyrosinase-related protein 2/DOPACHrome tautomerase gene. *Biochim Biophys Acta* 1492: 505-508, 2000.
14. **Ameen M, Exarchou V, and Chu AC.** Topical calcipotriol as monotherapy and in combination with psoralen plus ultraviolet A in the treatment of vitiligo. *Br J Dermatol* 145: 476-479, 2001.
15. **Amenta F, Ricci A, Rossodivita I, Avola R, and Tayebati SK.** The dopaminergic system in hypertension. *Clin Exp Hypertens* 23: 15-24, 2001.
16. **Amicarelli F, Gasbarri A, Masciocco L, Pompili A, Pacitti C, Carlucci G, Palumbo G, and Miranda M.** The effect of intrastriatal injection of liposome-entrapped tyrosinase on the dopamine levels in the rat brain. *Cell Mol Biol* 45: 1093-1097, 1999.
17. **Amos B and Lotan R.** Retinoid-sensitive cells and cell lines. *Methods Enzymol* 190: 217-225, 1990.
18. **An S, Cutler G, Zhao JJ, Huang SG, Tian H, Li W, Liang L, Rich M, Bakleh A, Du J, Chen JL, and Dai K.** Identification and characterization of a melanin-concentrating hormone receptor. *Proc Natl Acad Sci USA* 98: 7576-7581, 2001.
19. **Ancans J, Tobin DJ, Hoogduijn MJ, Smit NP, Wakamatsu K, and Thody AJ.** Melanosomal pH controls rate of melanogenesis, eumelanin/phaeomelanin ratio and melanosome maturation in melanocytes and melanoma cells. *Exp Cell Res* 268: 26-35, 2001.
20. **Ansel JC, Luger TA, Lowry D, Perry P, Roop DR, and Mountz JD.** The expression and modulation of IL-1 alpha in murine keratinocytes. *J Immunol* 140: 2274-2278, 1988.
21. **Aoki H and Moro O.** Involvement of microphthalmia-associated transcription factor (MITF) in expression of human melanocortin-1 receptor (MC1R). *Life Sci* 71: 2171-2179, 2002.
22. **Arai H, Hori S, Aramori I, Ohkubo H, and Nakanishi S.** Cloning and expression of a cDNA encoding an endothelin receptor. *Nature* 348: 730-732, 1990.
23. **Argyropoulos G, Rankinen T, Neufeld DR, Rice T, Province MA, Leon AS, Skinner JS, Wilmore JH, Rao DC, and Bouchard C.** A polymorphism in the human agouti-related protein is associated with late-onset obesity. *J Clin Endocrinol Metab* 87: 4198-4202, 2002.
24. **Arnold J, Anthonioz P, and Marchand JP.** Depigmenting action of corticosteroids. Experimental study on guinea pigs. *Dermatologica* 151: 274-280, 1975.
25. **Asanuma M, Miyazaki I, and Ogawa N.** Dopamine- or L-DOPA-induced neurotoxicity: the role of dopamine quinone formation and tyrosinase in a model of Parkinson's disease. *Neurotoxicol Res* 5: 165-176, 2003.
26. **Ashby B.** Co-expression of prostaglandin receptors with opposite effects: a model for homeostatic control of autocrine and paracrine signaling. *Biochem Pharmacol* 55: 239-246, 1998.
27. **Ashida Y, Denda M, and Hirao T.** Histamine H1 and H2 receptor antagonists accelerate skin barrier repair and prevent epidermal hyperplasia induced by barrier disruption in a dry environment. *J Invest Dermatol* 116: 261-265, 2001.

28. **Aubock J, Niederwieser D, Romani N, Fritsch P, and Huber C.** Human interferon-gamma induces expression of HLA-DR on keratinocytes and melanocytes. *Arch Dermatol Res* 277: 270–275, 1985.
29. **Axelrod J and Lerner AB.** O-methylation in the conversion of tyrosine to melanin. *Biochim Biophys Acta* 71: 650–655, 1963.
30. **Baker BI, Bird DJ, and Buckingham JC.** Salmonid melanin-concentrating hormone inhibits corticotrophin release. *J Endocrinol* 106: R5–R8, 1985.
31. **Baldwin CT, Hoth CF, Amos JA, da-Silva EO, and Milunsky A.** An exonic mutation in the HuP2 paired domain gene causes Waardenburg's syndrome. *Nature* 355: 637–638, 1992.
32. **Barton DE, Kwon BS, and Francke U.** Human tyrosinase gene, mapped to chromosome 11 (q14—q21), defines second region of homology with mouse chromosome 7. *Genomics* 3: 17–24, 1988.
33. **Basrur V, Yang F, Kushimoto T, Higashimoto Y, Yasumoto K, Valencia J, Muller J, Vieira WD, Watabe H, Shabanowitz J, Hearing VJ, Hunt DF, and Appella E.** Proteomic analysis of early melanosomes: identification of novel melanosomal proteins. *J Proteome Res* 2: 69–79, 2003.
34. **Baynash AG, Hosoda K, Giaid A, Richardson JA, Emoto N, Hammer RE, and Yanagisawa M.** Interaction of endothelin-3 with endothelin-B receptor is essential for development of epidermal melanocytes and enteric neurons. *Cell* 79: 1277–1285, 1994.
35. **Beaulieu M, Felder R, and Kebabian JW.** D-2 dopaminergic agonists and adenosine 3',5'-monophosphate directly regulate the synthesis of alpha-melanocyte-stimulating hormone-like peptides by cultured rat melanotrophs. *Endocrinology* 118: 1032–1039, 1986.
36. **Beauvais-Jouneau A, Pla P, Bernex F, Dufour S, Salamero J, Fassler R, Panthier JJ, Thiery JP, and Larue L.** A novel model to study the dorsolateral migration of melanoblasts. *Mech Dev* 89: 3–14, 1999.
37. **Beavan S, Horner A, Bord S, Ireland D, and Compston J.** Colocalization of glucocorticoid and mineralocorticoid receptors in human bone. *J Bone Miner Res* 16: 1496–1504, 2001.
38. **Bech-Thomsen N, Munch-Petersen B, Lundgren K, Poulsen T, and Wulf HC.** UV-induced alterations in skin and lymphocytes during a one-week holiday in the Canary Islands in May. *Acta Derm Venereol* 73: 422–425, 1993.
39. **Bell M.** Ultrastructure of differentiating hair follicles. In: *Advances in Biology of Skin*, edited by Montagna W and Dobson RL. New York: Pergamon, 1967, p. 61–81.
40. **Benedetto JP, Ortonne JP, Voulot C, Khatchadourian C, Prota G, and Thivolet J.** Role of thiol compounds in mammalian melanin pigmentation. II. Glutathione and related enzymatic activities. *J Invest Dermatol* 79: 422–424, 1982.
41. **Benjannet S, Rondeau N, Day R, Chretien M, and Seidah NG.** PC1 and PC2 are proprotein convertases capable of cleaving pro-opiomelanocortin at distinct pairs of basic residues. *Proc Natl Acad Sci USA* 88: 3564–3568, 1991.
42. **Bentley H, Hamdy FC, Hart KA, Seid JM, Williams JL, Johnstone D, and Russell RG.** Expression of bone morphogenetic proteins in human prostatic adenocarcinoma and benign prostatic hyperplasia. *Br J Cancer* 66: 1159–1163, 1992.
43. **Bergh K, Wentzel P, and Stjernschantz J.** Production of prostaglandin E(2) by iridial melanocytes exposed to latanoprost acid, a prostaglandin F(2 alpha) analogue. *J Ocul Pharmacol Ther* 18: 391–400, 2002.
44. **Bergquist J, Tarkowski A, Ewing A, and Ekman R.** Catecholaminergic suppression of immunocompetent cells. *Immunol Today* 19: 562–567, 1998.
45. **Bertazzo A, Biasiolo M, Costa C, Allegri G, Elli G, Seraglia R, and Traldi P.** Laser desorption ionization mass spectrometry in the study of natural and synthetic melanins. II. Serotonin melanins. *Biol Mass Spectrom* 23: 391–398, 1994.
46. **Bertazzo A, Costa C, Biasiolo M, Allegri G, Cirrincione G, and Presti G.** Determination of copper and zinc levels in human hair: influence of sex, age, and hair pigmentation. *Biol Trace Elem Res* 52: 37–53, 1996.
47. **Bertolotto C, Abbe P, Hemesath TJ, Bille K, Fisher DE, Ortonne JP, and Ballotti R.** Microphthalmia gene product as a signal transducer in cAMP-induced differentiation of melanocytes. *J Cell Biol* 142: 827–835, 1998.
48. **Bertolotto C, Bille K, Ortonne JP, and Ballotti R.** In B16 melanoma cells, the inhibition of melanogenesis by TPA results from PKC activation and diminution of microphthalmia binding to the M-box of the tyrosinase promoter. *Oncogene* 16: 1665–1670, 1998.
49. **Bertolotto C, Busca R, Abbe P, Bille K, Aberdam E, Ortonne JP, and Ballotti R.** Different cis-acting elements are involved in the regulation of TRP1 and TRP2 promoter activities by cyclic AMP: pivotal role of M boxes (GTCATGTGCT) and of microphthalmia. *Mol Cell Biol* 18: 694–702, 1998.
50. **Besmer P, Manova K, Duttlinger R, Huang EJ, Packer A, Gyssler C, and Bachvarova RF.** The kit-ligand (steel factor) and its receptor *c-kit/W*: pleiotropic roles in gametogenesis and melanogenesis. *Dev Suppl*: 125–137, 1993.
51. **Besmer P, Murphy JE, George PC, Qiu FH, Bergold PJ, Lederman L, Snyder HW Jr, Brodeur D, Zuckerman EE, and Hardy WD.** A new acute transforming feline retrovirus and relationship of its oncogene *v-kit* with the protein kinase gene family. *Nature* 320: 415–421, 1986.
52. **Bhawan J, Gonzalez-Serva A, Nehal K, Labadie R, Lufrano L, Thorne EG, and Gilchrist BA.** Effects of tretinoin on photodamaged skin. A histologic study. *Arch Dermatol* 127: 666–672, 1991.
53. **Bigliardi PL, Bigliardi-Qi M, Buechner S, and Ruffi T.** Expression of mu-opiate receptor in human epidermis and keratinocytes. *J Invest Dermatol* 111: 297–301, 1998.
54. **Bigliardi PL, Sumanovski LT, Buchner S, Ruffi T, and Bigliardi-Qi M.** Different expression of mu-opiate receptor in chronic and acute wounds and the effect of beta-endorphin on transforming growth factor beta type II receptor and cytokeratin 16 expression. *J Invest Dermatol* 120: 145–152, 2003.
55. **Bigliardi-Qi M, Bigliardi PL, Eberle AN, Buchner S, and Ruffi T.** Beta-endorphin stimulates cytokeratin 16 expression and down-regulates mu-opiate receptor expression in human epidermis. *J Invest Dermatol* 114: 527–532, 2000.
56. **Bikle D.** Molecular mechanisms underlying 1,25(OH)₂D regulation of epidermal differentiation. In: *Vitamin D. Chemistry, Biology, and Clinical Applications of the Steroid Hormone*. Riverside, CA: Univ. of California, 1997, p. 543–550.
57. **Billingham RE and Silvers WK.** A biologist's reflections on dermatology. *J Invest Dermatol* 57: 227–240, 1971.
58. **Bilodeau ML, Greulich JD, Hullinger RL, Bertolotto C, Ballotti R, and Andrisani OM.** BMP-2 stimulates tyrosinase gene expression and melanogenesis in differentiated melanocytes. *Pigment Cell Res* 14: 328–336, 2001.
59. **Birchall N, Orlow SJ, Kupper T, and Pawelek J.** Interactions between ultraviolet light and interleukin-1 on MSH binding in both mouse melanoma and human squamous carcinoma cells. *Biochem Biophys Res Commun* 175: 839–845, 1991.
60. **Black AK, Greaves MW, Hensby CN, and Plummer NA.** Increased prostaglandins E2 and F2alpha in human skin at 6 and 24 h after ultraviolet B irradiation (290–320 nm). *Br J Clin Pharmacol* 5: 431–436, 1978.
61. **Blois MS, Zahlan AB, and Maling JE.** Electron spin resonance studies on melanins. *Biophys J* 4: 471–490, 1964.
62. **Boissy RE, Sakai C, Zhao H, Kobayashi T, and Hearing VJ.** Human tyrosinase related protein-1 (TRP-1) does not function as a DHICA oxidase activity in contrast to murine TRP-1. *Exp Dermatol* 7: 198–204, 1998.
63. **Bolognia J, Murray M, and Pawelek J.** UVB-induced melanogenesis may be mediated through the MSH-receptor system. *J Invest Dermatol* 92: 651–656, 1989.
64. **Bolognia JL, Murray MS, and Pawelek JM.** Hairless pigmented guinea pigs: a new model for the study of mammalian pigmentation. *Pigment Cell Res* 3: 150–156, 1990.
65. **Bomirski A, Slominski A, and Bigda J.** The natural history of a family of transplantable melanomas in hamsters. *Cancer Met Rev* 7: 95–119, 1988.
66. **Boni R, Lichtensteiger W, Steinert HC, Boni RA, Fruh H, Dummer R, Hartmann DG, Laine E, and Burg G.** D1 dopamine receptors are not expressed in human melanoma. *Melanoma Res* 7: 117–119, 1997.
67. **Boni R, Steinert H, Boni RA, Lichtensteiger W, Dummer R, Hartmann DS, von Schulthess GK, Burg G, and Westera G.** Lack

- of expression of dopamine D2 receptors in malignant melanoma: evidence for interaction of iodobenzofurans with melanin. *Dermatology* 193: 198–202, 1996.
68. **Borovansky J and Elleder M.** Melanosome degradation: fact or fiction. *Pigment Cell Res* 16: 280–286, 2003.
 69. **Borski RJ.** Nongenomic membrane actions of glucocorticoids in vertebrates. *Trends Endocrinol Metab* 11: 427–436, 2000.
 70. **Botchkarev VA, Botchkareva NV, Sharov AA, Funa K, Huber O, and Gilchrist BA.** Modulation of BMP signaling by noggin is required for induction of the secondary (nonyltoch) hair follicles. *J Invest Dermatol* 118: 3–10, 2002.
 71. **Botchkareva NV, Khlgatian M, Longley BJ, Botchkarev VA, and Gilchrist BA.** SCF/*c-kit* signaling is required for cyclic regeneration of the hair pigmentation unit. *FASEB J* 15: 645–658, 2001.
 72. **Box NF, Wyeth JR, Mayne CJ, O’Gorman LE, Martin NG, and Sturm RA.** Complete sequence and polymorphism study of the human TYRP1 gene encoding tyrosinase-related protein 1. *Mamm Genome* 9: 50–53, 1998.
 73. **Boyan BD, Bonewald LF, Sylvia VL, Nemere I, Larsson D, Norman AW, Rosser J, Dean DD, and Schwartz Z.** Evidence for distinct membrane receptors for 1 α ,25-(OH) $_2$ D $_3$ and 24R,25-(OH) $_2$ D $_3$ in osteoblasts. *Steroids* 67: 235–246, 2002.
 74. **Branda RF and Eaton JW.** Skin color and nutrient photolysis: an evolutionary hypothesis. *Science* 201: 625–626, 1978.
 75. **Brandenberger AW, Tee MK, Lee JY, Chao V, and Jaffe RB.** Tissue distribution of estrogen receptors alpha (ER-alpha) and beta (ER-beta) mRNA in the midgestational human fetus. *J Clin Endocrinol Metab* 82: 3509–3512, 1997.
 76. **Brannan CI, Lyman SD, Williams DE, Eisenman J, Anderson DM, Cosman D, Bedell MA, Jenkins NA, and Copeland NG.** Steel-Dickie mutation encodes a *c-kit* ligand lacking transmembrane and cytoplasmic domains. *Proc Natl Acad Sci USA* 88: 4671–4674, 1991.
 77. **Breakefield XO, Castiglione CM, Halaban R, Pawelek J, and Shiman R.** Phenylalanine hydroxylase in melanoma cells. *J Cell Physiol* 94: 307–314, 1978.
 78. **Brilliant M and Gardner J.** Melanosomal pH, pink locus protein and their roles in melanogenesis. *J Invest Dermatol* 117: 386–387, 2001.
 79. **Brinkmann AO, Blok LJ, de Ruiter PE, Doesburg P, Steketeer K, Berrevoets CA, and Trapman J.** Mechanisms of androgen receptor activation and function. *J Steroid Biochem Mol Biol* 69: 307–313, 1999.
 80. **Broudy VC.** Stem cell factor and hematopoiesis. *Blood* 90: 1345–1364, 1997.
 81. **Bucala R.** MIF rediscovered: cytokine, pituitary hormone, and glucocorticoid-induced regulator of the immune response. *FASEB J* 10: 1607–1613, 1996.
 82. **Buchli R, Ndoye A, Arredondo J, Webber RJ, and Grando SA.** Identification and characterization of muscarinic acetylcholine receptor subtypes expressed in human skin melanocytes. *Mol Cell Biochem* 228: 57–72, 2001.
 83. **Buchli R, Ndoye A, Slominski A, and Grando SA.** Cholinergic control of melanogenesis. *J Invest Dermatol* 114: 859, 2000.
 84. **Budd PS and Jackson IJ.** Structure of the mouse tyrosinase-related protein-2/dopachrome tautomerase (Tyrp2/Dct) gene and sequence of two novel slaty alleles. *Genomics* 29: 35–43, 1995.
 85. **Buffey J, Thody AJ, Bleehen SS, and MacNeil S.** Alpha-melanocyte-stimulating hormone stimulates protein kinase C activity in murine B16 melanoma. *J Endocrinol* 133: 333–340, 1992.
 86. **Bulengo-Ransby SM, Griffiths CE, Kimbrough-Green CK, Finkel LJ, Hamilton TA, Ellis CN, and Voorhees JJ.** Topical tretinoin (retinoic acid) therapy for hyperpigmented lesions caused by inflammation of the skin in black patients. *N Engl J Med* 328: 1438–1443, 1993.
 87. **Bultman SJ, Michaud EJ, and Woychik RP.** Molecular characterization of the mouse agouti locus. *Cell* 71: 1195–1204, 1992.
 88. **Burchill SA and Thody AJ.** Dopaminergic inhibition of tyrosinase activity in hair follicular melanocytes of the mouse. *J Endocrinol* 111: 233–237, 1986.
 89. **Burchill SA and Thody AJ.** Melanocyte-stimulating hormone and the regulation of tyrosinase activity in hair follicular melanocytes of the mouse. *J Endocrinol* 111: 225–232, 1986.
 90. **Burchill SA, Virden R, Fuller BB, and Thody AJ.** Regulation of tyrosinase synthesis by alpha-melanocyte-stimulating hormone in hair follicular melanocytes of the mouse. *J Endocrinol* 116: 17–23, 1988.
 91. **Burgers ACJ, Boschman A, and van de Kamer JC.** Excitement darkening and the effect of adrenaline on the melanophores of *Xenopus laevis*. *Acta Endocrinol* 14: 72–82, 1963.
 92. **Busca R and Ballotti R.** Cyclic AMP a key messenger in the regulation of skin pigmentation. *Pigment Cell Res* 13: 60–69, 2000.
 93. **Busca R, Bertolotto C, Abbe P, Englaro W, Ishizaki T, Narumiya S, Boquet P, Ortonne JP, and Ballotti R.** Inhibition of Rho is required for cAMP-induced melanoma cell differentiation. *Mol Biol Cell* 9: 1367–1378, 1998.
 94. **Busca R, Bertolotto C, Ortonne JP, and Ballotti R.** Inhibition of the phosphatidylinositol 3-kinase/p70(S6)-kinase pathway induces B16 melanoma cell differentiation. *J Biol Chem* 271: 31824–31830, 1996.
 95. **Butler AA, Kesterson RA, Khong K, Cullen MJ, Pelley-mounter MA, Dekoning J, Baetscher M, and Cone RD.** A unique metabolic syndrome causes obesity in the melanocortin-3 receptor-deficient mouse. *Endocrinology* 141: 3518–3521, 2000.
 96. **Buznikov GA, Lambert HW, and Lauder JM.** Serotonin and serotonin-like substances as regulators of early embryogenesis and morphogenesis. *Cell Tissue Res* 305: 177–186, 2001.
 97. **Carlson JA, Slominski A, Linette GP, Mihm MC Jr, and Ross JS.** Biomarkers in melanoma: predisposition, screening and diagnosis. *Expert Rev Mol Diagn* 3: 163–184, 2003.
 98. **Carreira S, Dexter TJ, Yavuzer U, Easty DJ, and Goding CR.** Brachyury-related transcription factor Tbx2 and repression of the melanocyte-specific TRP-1 promoter. *Mol Cell Biol* 18: 5099–5108, 1998.
 99. **Carreira S, Liu B, and Goding CR.** The gene encoding the T-box factor Tbx2 is a target for the microphthalmia-associated transcription factor in melanocytes. *J Biol Chem* 275: 21920–21927, 2000.
 100. **Carroll JM, Crompton T, Seery JP, and Watt FM.** Transgenic mice expressing IFN-gamma in the epidermis have eczema, hair hypopigmentation, and hair loss. *J Invest Dermatol* 108: 412–422, 1997.
 101. **Carstam R, Brinck C, Hindemith-Augustsson A, Rorsman H, and Rosengren E.** The neuromelanin of the human substantia nigra. *Biochim Biophys Acta* 1097: 152–160, 1991.
 102. **Castroviejo DA, Escames G, Carazo A, Leon J, Khaldy H, and Reiter RJ.** Melatonin, mitochondrial homeostasis and mitochondrial-related diseases. *Curr Top Med Chem* 2: 133–151, 2002.
 103. **Chakraborty A, Pawelek JM, Bologna J, Funasaka Y, and Slominski A.** UV light and MSH receptors. *Ann NY Acad Sci* 885: 100–116, 1999.
 104. **Chakraborty A, Slominski A, Ermak G, Hwang J, and Pawelek J.** Ultraviolet and melanocyte-stimulating hormone (MSH) stimulate mRNA production of α -MSH receptors and proopiomelanocortin-derived peptides in mouse melanoma cells and transformed keratinocytes. *J Invest Dermatol* 105: 655–659, 1995.
 105. **Chakraborty A, Slominski A, Ermak G, Hwang J, and Pawelek J.** Ultraviolet B and melanocyte-stimulating hormone (MSH) stimulate mRNA production for alpha MSH receptors and proopiomelanocortin-derived peptides in mouse melanoma cells and transformed keratinocytes. *J Invest Dermatol* 105: 655–659, 1995.
 106. **Chakraborty AK, Funasaka Y, Slominski A, Ermak G, Hwang J, Pawelek JM, and Ichihashi M.** Production and release of proopiomelanocortin (POMC) derived peptides by human melanocytes and keratinocytes in culture: regulation by ultraviolet B. *Biochim Biophys Acta* 1313: 130–138, 1996.
 107. **Chakraborty AK, Orlow SJ, Bologna JL, and Pawelek JM.** Structural/functional relationships between internal and external MSH receptors: modulation of expression in Cloudman melanoma cells by UVB radiation. *J Cell Physiol* 147: 1–6, 1991.
 108. **Chakraborty AK, Orlow SJ, and Pawelek JM.** Stimulation of the receptor for melanocyte-stimulating hormone by retinoic acid. *FEBS Lett* 276: 205–208, 1990.
 109. **Chakraborty AK, Platt JT, Kim KK, Kwon BS, Bennett DC, and Pawelek JM.** Polymerization of 5,6-dihydroxyindole-2-carboxylic acid to melanin by the pmel 17/silver locus protein. *Eur J Biochem* 236: 180–188, 1996.

110. Chambers J, Ames RS, Bergsma D, Muir A, Fitzgerald LR, Hervieu G, Dytko GM, Foley JJ, Martin J, Liu WS, Park J, Ellis C, Ganguly S, Konchar S, Cluderay J, Leslie R, Wilson S, and Sarau HM. Melanin-concentrating hormone is the cognate ligand for the orphan G-protein-coupled receptor SLC-1. *Nature* 400: 261–265, 1999.
111. Chang CS, Kokontis J, and Liao ST. Structural analysis of complementary DNA and amino acid sequences of human and rat androgen receptors. *Proc Natl Acad Sci USA* 85: 7211–7215, 1988.
112. Chase HB. Growth of hair. *Physiol Rev* 34: 113–126, 1954.
113. Chen AS, Metzger JM, Trumbauer ME, Guan XM, Yu H, Frazier EG, Marsh DJ, Forrester MJ, Gopal-Truter S, Fisher J, Camacho RE, Strack AM, Mellin TN, MacIntyre DE, Chen HY, and Van der Ploeg LH. Role of the melanocortin-4 receptor in metabolic rate and food intake in mice. *Transgenic Res* 9: 145–154, 2000.
114. Chen CL, Dionne FT, and Roberts JL. Regulation of the pro-opiomelanocortin mRNA levels in rat pituitary by dopaminergic compounds. *Proc Natl Acad Sci USA* 80: 2211–2215, 1983.
115. Chen K, Manga P, and Orlow SJ. Pink-eyed dilution protein controls the processing of tyrosinase. *Mol Biol Cell* 13: 1953–1964, 2002.
116. Chen W, Kelly MA, Opitz-Araya X, Thomas RE, Low MJ, and Cone RD. Exocrine gland dysfunction in MC5R-deficient mice: evidence for coordinated regulation of exocrine gland function by melanocortin peptides. *Cell* 91: 789–798, 1997.
117. Chen W, Zouboulis CC, Fritsch M, Blume-Peytavi U, Kodolija V, Goerdts S, Luu-The V, and Orfanos CE. Evidence of heterogeneity and quantitative differences of the type 1 5 α -reductase expression in cultured human skin cells—evidence of its presence in melanocytes. *J Invest Dermatol* 110: 84–89, 1998.
118. Cherifi Y, Pigeon C, Le Romancer M, Bado A, Rey-Desmars F, and Lewin MJ. Purification of a histamine H3 receptor negatively coupled to phosphoinositide turnover in the human gastric cell line HGT1. *J Biol Chem* 267: 25315–25320, 1992.
119. Chhajlani V, Muceniece R, and Wikberg JE. Molecular cloning of a novel human melanocortin receptor. *Biochem Biophys Res Commun* 195: 866–873, 1993.
120. Chhajlani V and Wikberg JE. Molecular cloning and expression of the human melanocyte stimulating hormone receptor cDNA. *FEBS Lett* 309: 417–420, 1992.
121. Christoph T, Muller-Rover S, Audring H, Tobin DJ, Hermes B, Cotsarelis G, Ruckert R, and Paus R. The human hair follicle immune system: cellular composition and immune privilege. *Br J Dermatol* 142: 862–873, 2000.
122. Church MK, el-Lati S, and Okayama Y. Biological properties of human skin mast cells. *Clin Exp Allergy* 21 Suppl 3: 1–9, 1991.
123. Clark EA and Hill SJ. Sensitivity of histamine H3 receptor agonist-stimulated [³⁵S]GTP gamma[S] binding to pertussis toxin. *Eur J Pharmacol* 296: 223–225, 1996.
124. Clouthier DE, Hosoda K, Richardson JA, Williams SC, Yanagisawa H, Kuwaki T, Kumada M, Hammer RE, and Yanagisawa M. Cranial and cardiac neural crest defects in endothelin-A receptor-deficient mice. *Development* 125: 813–824, 1998.
125. Colston K, Colston MJ, and Feldman D. 1,25-Dihydroxyvitamin D₃ and malignant melanoma: the presence of receptors and inhibition of cell growth in culture. *Endocrinology* 108: 1083–1086, 1981.
126. Commoner B, Townsend J, and Pake GW. Free radicals in biological materials. *Nature* 174: 689–691, 1954.
127. Cone RD, Lu D, Koppula S, Vage DI, Klungland H, Boston B, Chen W, Orth DN, Pouton C, and Kesterson RA. The melanocortin receptors: agonists, antagonists, and the hormonal control of pigmentation. *Recent Prog Horm Res* 51: 287–318, 1996.
128. Cone RD, Mountjoy KG, Robbins LS, Nadeau JH, Johnson KR, Roselli-Rehfuess L, and Mortrud MT. Cloning and functional characterization of a family of receptors for the melanotropic peptides. *Ann NY Acad Sci* 680: 342–363, 1993.
129. Connor M and Christie MD. Opioid receptor signalling mechanisms. *Clin Exp Pharmacol Physiol* 26: 493–499, 1999.
130. Cornwell ML, Comstock GW, Holick MF, and Bush TL. Prediagnostic serum levels of 1,25-dihydroxyvitamin D and malignant melanoma. *Photodermatol Photoimmunol Photomed* 9: 109–112, 1992.
131. Costa JJ, Demetri GD, Harrist TJ, Dvorak AM, Hayes DF, Merica EA, Menchaca DM, Gringeri AJ, Schwartz LB, and Galli SJ. Recombinant human stem cell factor (kit ligand) promotes human mast cell and melanocyte hyperplasia and functional activation in vivo. *J Exp Med* 183: 2681–2686, 1996.
132. Costin GE, Valencia JC, Vieira WD, Lamoreux ML, and Hearing VJ. Tyrosinase processing and intracellular trafficking is disrupted in mouse primary melanocytes carrying the underwhite (*uw*) mutation. A model for oculocutaneous albinism (OCA) type 4. *J Cell Sci* 116: 3203–3212, 2003.
133. Cowled PA, Mackenzie L, and Forbes IJ. Potentiation of photodynamic therapy with haematoporphyrin derivatives by glucocorticoids. *Cancer Lett* 29: 107–114, 1985.
134. Crowley P, Lai NY, De Young N, Pearce P, Funder JW, and Gill PG. Inhibition of growth of B16 melanoma by glucocorticoids does not result directly from receptor-mediated inhibition of tumour cells. *Oncology* 45: 331–335, 1988.
135. Cucchi ML, Frattini P, Santagostino G, and Orecchia G. Higher plasma catecholamine and metabolite levels in the early phase of nonsegmental vitiligo. *Pigment Cell Res* 13: 28–32, 2000.
136. Dahlen SE. Pharmacological characterization of leukotriene receptors. *Am J Respir Crit Care Med* 161: S41–S45, 2000.
137. Dalayoun JF, Nores JM, and Bergal S. Physiology of beta-endorphins. A close-up view and a review of the literature. *Biomed Pharmacother* 47: 311–320, 1993.
138. Danielsson C, Fehsel K, Polly P, and Carlberg C. Differential apoptotic response of human melanoma cells to 1 alpha,25-dihydroxyvitamin D₃ and its analogues. *Cell Death Differ* 5: 946–952, 1998.
139. Daniolos A, Lerner AB, and Lerner MR. Action of light on frog pigment cells in culture. *Pigment Cell Res* 3: 38–43, 1990.
140. Del Marmol V and Beermann F. Tyrosinase and related proteins in mammalian pigmentation. *FEBS Lett* 381: 165–168, 1996.
141. Del Marmol V, Ito S, Bouchard B, Libert A, Wakamatsu K, Ghanem G, and Solano F. Cysteine deprivation promotes eumelanogenesis in human melanoma cells. *J Invest Dermatol* 107: 698–702, 1996.
142. Del Marmol V, Ito S, Jackson I, Vachtenheim J, Berr P, Ghanem G, Morandini R, Wakamatsu K, and Huez G. TRP-1 expression correlates with eumelanogenesis in human pigment cells in culture. *FEBS Lett* 327: 307–310, 1993.
143. Denko CW, Aponte J, Gabriel P, and Petricevic M. β -Endorphin, immunological and biochemical changes in synovial fluid in rheumatic disorders. *Clin Rheumatol* 5: 25–32, 1986.
144. Derynck R and Feng XH. TGF-beta receptor signaling. *Biochim Biophys Acta* 1333: F105–F150, 1997.
145. Devi CC, Tripathi RK, and Ramaiah A. pH-dependent interconvertible allosteric forms of murine melanoma tyrosinase. Physiological implications. *Eur J Biochem* 166: 705–711, 1987.
146. Diarra A, Lefauconnier JM, Valens M, Georges P, and Grippois D. Tyrosine content, influx and accumulation rate, and catecholamine biosynthesis measured in vivo, in the central nervous system and in peripheral organs of the young rat. Influence of neonatal hypo- and hyperthyroidism. *Arch Int Physiol Biochim* 97: 317–332, 1989.
147. Diaz LC, Das Gupta TK, and Beattie CW. Effects of gonadal steroids on melanocytes in developing hamsters. *Pediatr Dermatol* 3: 247–256, 1986.
148. Dinulescu DM, Fan W, Boston BA, McCall K, Lamoreux ML, Moore KJ, Montagno J, and Cone RD. Mahogany (*mg*) stimulates feeding and increases basal metabolic rate independent of its suppression of agouti. *Proc Natl Acad Sci USA* 95: 12707–12712, 1998.
149. DiPasquale A, McGuire J, and Varga JM. The number of receptors for beta-melanocyte stimulating hormone in Cloudman melanoma cells is increased by dibutylryl adenosine 3':5'-cyclic monophosphate or cholera toxin. *Proc Natl Acad Sci USA* 74: 601–605, 1977.
150. DiSorbo DM, McNulty B, and Nathanson L. In vitro growth inhibition of human malignant melanoma cells by glucocorticoids. *Cancer Res* 43: 2664–2667, 1983.
151. Double KL, Zecca L, Costi P, Mauer M, Griesinger C, Ito S, Ben-Shachar D, Bringmann G, Fariello RG, Riederer P, and

- Gerlach M. Structural characteristics of human substantia nigra neuromelanin and synthetic dopamine melanins. *J Neurochem* 75: 2583–2589, 2000.
152. Duell EA, Astrom A, Griffiths CE, Chambon P, and Voorhees JJ. Human skin levels of retinoic acid and cytochrome P-450-derived 4-hydroxyretinoic acid after topical application of retinoic acid in vivo compared with concentrations required to stimulate retinoic acid receptor-mediated transcription in vitro. *J Clin Invest* 90: 1269–1274, 1992.
 153. Duhl DM, Stevens ME, Vrieling H, Saxon PJ, Miller MW, Epstein CJ, and Barsh GS. Pleiotropic effects of the mouse lethal yellow (*Ay*) mutation explained by deletion of a maternally expressed gene and the simultaneous production of agouti fusion RNAs. *Development* 120: 1695–1708, 1994.
 154. Dupin E and Le Douarin NM. Retinoic acid promotes the differentiation of adrenergic cells and melanocytes in quail neural crest cultures. *Dev Biol* 168: 529–548, 1995.
 155. Dupin E and Le Douarin NM. Development of melanocyte precursors from the vertebrate neural crest. *Oncogene* 22: 3016–3023, 2003.
 156. Duttlinger R, Manova K, Chu TY, Gyssler C, Zelenetz AD, Bachvarova RF, and Besmer P. W-sash affects positive and negative elements controlling *c-kit* expression: ectopic *c-kit* expression at sites of *kit*-ligand expression affects melanogenesis. *Development* 118: 705–717, 1993.
 157. Eberle AN. *The Melanotropins: Chemistry, Physiology and Mechanism of Action*. New York: Karger, 1988.
 158. Eberle J, Weitmann S, Thieck O, Pech H, Paul M, and Orfanos CE. Downregulation of endothelin B receptor in human melanoma cell lines parallel to differentiation genes. *J Invest Dermatol* 112: 925–932, 1999.
 159. Edward M, Gold JA, and MacKie RM. Different susceptibilities of melanoma cells to retinoic acid-induced changes in melanotic expression. *Biochem Biophys Res Commun* 155: 773–778, 1988.
 160. Eisen T, Easty DJ, Bennett DC, and Goding CR. The POU domain transcription factor Brn-2: elevated expression in malignant melanoma and regulation of melanocyte-specific gene expression. *Oncogene* 11: 2157–2164, 1995.
 161. Eisenhofer G, Tian H, Holmes C, Matsunaga J, Roffler-Tarlov S, and Hearing VJ. Tyrosinase: a developmentally specific major determinant of peripheral dopamine. *FASEB J* 17: 1248–1255, 2003.
 162. Eisinger M, Marko O, Ogata S, and Old LJ. Growth regulation of human melanocytes: mitogenic factors in extracts of melanoma, astrocytoma, and fibroblast cell lines. *Science* 229: 984–986, 1985.
 163. Eison AS and Mullins UL. Melatonin binding sites are functionally coupled to phosphoinositide hydrolysis in Syrian hamster RPMI 1846 melanoma cells. *Life Sci* 53: 393–398, 1993.
 164. Elleder M and Borovansky J. Autofluorescence of melanins induced by ultraviolet radiation and near ultraviolet light. A histochemical and biochemical study. *Histochem J* 33: 273–281, 2001.
 165. Eller MS and Gilchrist BA. Tanning as part of the eukaryotic SOS response. *Pigment Cell Res* 13 Suppl 8: 94–97, 2000.
 166. Eller MS, Hadshiew IM, and Gilchrist BA. The role of DNA damage and telomeres in melanogenesis. In: *Mechanisms of Sun-tanning*, edited by Ortonne JP and Ballotti R. London: Martin Dunitz, 2002, p. 239–245.
 167. Englaro W, Bahadoran P, Bertolotto C, Busca R, Derijard B, Livolsi A, Peyron JF, Ortonne JP, and Ballotti R. Tumor necrosis factor alpha-mediated inhibition of melanogenesis is dependent on nuclear factor kappa B activation. *Oncogene* 18: 1553–1559, 1999.
 168. Englaro W, Bertolotto C, Busca R, Brunet A, Pages G, Ortonne JP, and Ballotti R. Inhibition of the mitogen-activated protein kinase pathway triggers B16 melanoma cell differentiation. *J Biol Chem* 273: 9966–9970, 1998.
 169. Ermak G and Slominski A. Production of POMC, CRH-R1, MC1, and MC2 receptor mRNA and expression of tyrosinase gene in relation to hair cycle and dexamethasone treatment in the C57BL/6 mouse skin. *J Invest Dermatol* 108: 160–165, 1997.
 170. Eshel Y and Salomon Y. Calmodulin-binding peptides interfere with melanocyte-stimulating hormone receptor activity and stimulate adenosine 3',5'-monophosphate production in M2R mouse melanoma cells. *Endocrinology* 134: 177–185, 1994.
 171. Evans TRJ, Hamberg KJ, and Skov T. Seocalcitol (EB 1089): clinical experience to date. In: *Vitamin D. Chemistry, Biology, and Clinical Applications of the Steroid Hormone*. Riverside, CA: Univ. of California, 1997, p. 485–488.
 172. Falus A, Hegyesi H, Lazar-Molnar E, Pos Z, Laszlo V, and Darvas Z. Paracrine and autocrine interactions in melanoma: histamine is a relevant player in local regulation. *Trends Immunol* 22: 648–652, 2001.
 173. Farah JM Jr, Bishop JF, Nguyen HQ, and O'Donohue TL. The effects of pro-opiomelanocortin peptides on cyclic AMP and tyrosinase in melanoma cells. *Peptides* 7: 437–441, 1986.
 174. Fehner GA, Michel J, Sturm RA, Jacobs JJ, and Parsons PG. Reduction of DNA synthesis, pigment synthesis, pigmentation gene mRNA and resistance to UVB in human melanoma cells treated with analogues of a histamine (H2) agonist. *Biochem Pharmacol* 48: 121–130, 1994.
 175. Feskanich D, Hunter DJ, Willett WC, Spiegelman D, Stampfer MJ, Speizer FE, and Colditz GA. Oral contraceptive use and risk of melanoma in premenopausal women. *Br J Cancer* 81: 918–923, 1999.
 176. Filadelfi AM and Castrucci AM. Melatonin desensitizing effects on the in vitro responses to MCH, alpha-MSH, isoproterenol and melatonin in pigment cells of a fish (*S. marmoratus*), a toad (*B. ictericus*), a frog (*R. pipiens*), and a lizard (*A. carolinensis*), exposed to varying photoperiodic regimens. *Comp Biochem Physiol A Physiol* 109: 1027–1037, 1994.
 177. Fiorentini G, Rossi S, Lanzanova G, Bernardeschi P, Dentico P, and De Giorgi U. Potential use of imatinib mesylate in ocular melanoma and liposarcoma expressing immunohistochemical c-KIT (CD117). *Ann Oncol* 14: 805, 2003.
 178. Fischer AJ, McKinnon LA, Nathanson NM, and Stell WK. Identification and localization of muscarinic acetylcholine receptors in the ocular tissues of the chick. *J Comp Neurol* 392: 273–284, 1998.
 179. Fisher GJ, Talwar HS, Xiao JH, Datta SC, Reddy AP, Gaub MP, Rochette-Egly C, Chambon P, and Voorhees JJ. Immunological identification and functional quantitation of retinoic acid and retinoid X receptor proteins in human skin. *J Biol Chem* 269: 20629–20635, 1994.
 180. Fitzpatrick TB and Brethnach AS. The epidermal melanin-einheit system. *Dermatol Wochenschr* 147: 481–489, 1963.
 181. Fitzpatrick TB, Eisen AZ, Wolff K, Freedberg IM, and Austen KF. *Dermatology in General Medicine*. New York: McGraw-Hill, 1997.
 182. Fitzpatrick TB and Szabad G. The melanocyte: cytology and cytochemistry. *J Invest Derm* 32: 197, 1959.
 183. Fitzsimons C, Duran H, Engel N, Molinari B, and Rivera E. Changes in H2 receptor expression and coupling during Ca²⁺-induced differentiation in mouse epidermal keratinocytes. *Inflamm Res* 48 Suppl 1: S73–S74, 1999.
 184. Fleischman RA, Saltman DL, Stastny V, and Zneimer S. Deletion of the *c-kit* protooncogene in the human developmental defect piebald trait. *Proc Natl Acad Sci USA* 88: 10885–10889, 1991.
 185. Fligel SE, Inman DR, Talwar HS, Fisher GJ, Voorhees JJ, and Varani J. Modulation of growth in normal and malignant melanocytic cells by all-trans retinoic acid. *J Cutan Pathol* 19: 27–33, 1992.
 186. Friedman Z, Hackett SF, and Campochiaro PA. Human retinal pigment epithelial cells possess muscarinic receptors coupled to calcium mobilization. *Brain Res* 446: 11–16, 1988.
 187. Fujita H, Sasano E, Yasunaga K, Furuta K, Yokota S, Wada I, and Himeno M. Evidence for distinct membrane traffic pathways to melanosomes and lysosomes in melanocytes. *J Invest Dermatol Symp Proc* 6: 19–24, 2001.
 188. Fukuzawa T and Bagnara JT. Control of melanoblast differentiation in amphibia by alpha-melanocyte stimulating hormone, a serum melanization factor, and a melanization inhibiting factor. *Pigment Cell Res* 2: 171–181, 1989.
 189. Fukuzawa T and Ide H. A ventrally localized inhibitor of melanization in *Xenopus laevis* skin. *Dev Biol* 129: 25–36, 1988.
 190. Fuller BB, Lunsford JB, and Iman DS. Alpha-melanocyte-stimulating hormone regulation of tyrosinase in Cloudman S-91 mouse melanoma cell cultures. *J Biol Chem* 262: 4024–4033, 1987.

191. Fuller BB, Spaulding DT, and Smith DR. Regulation of the catalytic activity of preexisting tyrosinase in black and Caucasian human melanocyte cell cultures. *Exp Cell Res* 262: 197–208, 2001.
192. Funasaka Y, Chakraborty AK, Hayashi Y, Komoto M, Ohashi A, Nagahama M, Inoue Y, Pawelek J, and Ichihashi M. Modulation of melanocyte-stimulating hormone receptor expression on normal human melanocytes: evidence for a regulatory role of ultraviolet B, interleukin-1 α , interleukin-1 β , endothelin-1 and tumour necrosis factor- α . *Br J Dermatol* 139: 216–224, 1998.
193. Funasaka Y, Chakraborty AK, Komoto M, Ohashi A, and Ichihashi M. The depigmenting effect of alpha-tocopheryl ferulate on human melanoma cells. *Br J Dermatol* 141: 20–29, 1999.
194. Furuya R, Akiu S, Ideta R, Naganuma M, Fukuda M, and Hirobe T. Changes in the proliferative activity of epidermal melanocytes in serum-free primary culture during the development of ultraviolet radiation B-induced pigmented spots in hairless mice. *Pigment Cell Res* 15: 348–356, 2002.
195. Gadd SJ and Ashman LK. A murine monoclonal antibody specific for a cell-surface antigen expressed by a subgroup of human myeloid leukaemias. *Leukoc Res* 9: 1329–1336, 1985.
196. Galibert MD, Yavuzer U, Dexter TJ, and Goding CR. Pax3 and regulation of the melanocyte-specific tyrosinase-related protein-1 promoter. *J Biol Chem* 274: 26894–26900, 1999.
197. Ganss R, Montoliu L, Monaghan AP, and Schutz G. A cell-specific enhancer far upstream of the mouse tyrosinase gene confers high level and copy number-related expression in transgenic mice. *EMBO J* 13: 3083–3093, 1994.
198. Ganss R, Schmidt A, Schutz G, and Beermann F. Analysis of the mouse tyrosinase promoter in vitro and in vivo. *Pigment Cell Res* 7: 275–278, 1994.
199. Ganss R, Schutz G, and Beermann F. The mouse tyrosinase gene. Promoter modulation by positive and negative regulatory elements. *J Biol Chem* 269: 29808–29816, 1994.
200. Gantz I, Konda Y, Tashiro T, Shimoto Y, Miwa H, Munzert G, Watson SJ, DelValle J, and Yamada T. Molecular cloning of a novel melanocortin receptor. *J Biol Chem* 268: 8246–8250, 1993.
201. Gantz I, Miwa H, Konda Y, Shimoto Y, Tashiro T, Watson SJ, DelValle J, and Yamada T. Molecular cloning, expression, and gene localization of a fourth melanocortin receptor. *J Biol Chem* 268: 15174–15179, 1993.
202. Gantz I, Munzert G, Tashiro T, Schaffer M, Wang L, DelValle J, and Yamada T. Molecular cloning of the human histamine H2 receptor. *Biochem Biophys Res Commun* 178: 1386–1392, 1991.
203. Garcia RI. Ultrastructure of melanocyte-keratinocyte interactions. *Pigment Cell Res* 4: 299–310, 1979.
204. Gardner JM, Nakatsu Y, Gondo Y, Lee S, Lyon MF, King RA, and Brilliant MH. The mouse pink-eyed dilution gene: association with human Prader-Willi and Angelman syndromes. *Science* 257: 1121–1124, 1992.
205. Gaudet SJ, Slominski A, Etminan M, Pruski D, Paus R, and Namboordiri MAA. Identification and characterization of two isozymic forms of arylamine N-acetyltransferase in Syrian hamster skin. *J Invest Dermatol* 101: 660–665, 1993.
206. Gaveriaux-Ruff C and Keiffer BL. Opioid receptors: gene structure and function. In: *Opioids in Pain Control: Basic and Clinical Aspects*, edited by Stein C. Cambridge, UK: Cambridge Univ. Press, 1999, p. 1–20.
207. Gedalia A, Gewanter H, and Baum J. Dark skin discoloration of finger joints in juvenile arthritis. *J Rheumatol* 16: 797–799, 1989.
208. Geissler EN, Liao M, Brook JD, Martin FH, Zsebo KM, Housman DE, and Galli SJ. Stem cell factor (SCF), a novel hematopoietic growth factor and ligand for *c-kit* tyrosine kinase receptor, maps on human chromosome 12 between 12q14.3 and 12qter. *Somat Cell Mol Genet* 17: 207–214, 1991.
209. Geschwind II, Huseby RA, and Nishioka R. The effect of melanocyte-stimulating hormone on coat color in the mouse. *Recent Prog Horm Res* 28: 91–130, 1972.
210. Gidianian S and Farmer PJ. Redox behavior of melanins: direct electrochemistry of dihydroxyindole-melanin and its Cu and Zn adducts. *J Inorg Biochem* 89: 54–60, 2002.
211. Giebel LB and Spritz RA. Mutation of the KIT (mast/stem cell growth factor receptor) protooncogene in human piebaldism. *Proc Natl Acad Sci USA* 88: 8696–8699, 1991.
212. Gilchrist BA and Eller MS. DNA photodamage stimulates melanogenesis and other photoprotective responses. *J Invest Dermatol Symp Proc* 4: 35–40, 1999.
213. Gilchrist BA, Park HY, Eller MS, and Yaar M. Mechanisms of ultraviolet light-induced pigmentation. *Photochem Photobiol* 63: 1–10, 1996.
214. Gilmore W and Weiner LP. The opioid specificity of beta-endorphin enhancement of murine lymphocyte proliferation. *Immunopharmacology* 17: 19–30, 1989.
215. Glinski W, Brodecka H, Glinska-Ferenz M, and Kowalski D. Increased concentration of beta-endorphin in sera of patients with psoriasis and other inflammatory dermatoses. *Br J Dermatol* 131: 260–264, 1994.
216. Glinski W, Brodecka H, Glinska-Ferenz M, and Kowalski D. Increased concentration of beta-endorphin in the sera of patients with severe atopic dermatitis. *Acta Derm Venereol* 75: 9–11, 1995.
217. Gordon PR and Gilchrist BA. Human melanogenesis is stimulated by diacylglycerol. *J Invest Dermatol* 93: 700–702, 1989.
218. Grabbe J, Welker P, Dippel E, and Czarnetzki BM. Stem cell factor, a novel cutaneous growth factor for mast cells and melanocytes. *Arch Dermatol Res* 287: 78–84, 1994.
219. Graham RM, Perez DM, Hwa J, and Piasick MT. Alpha 1-adrenergic receptor subtypes. Molecular structure, function, and signaling. *Circ Res* 78: 737–749, 1996.
220. Grando SA. Biological functions of keratinocyte cholinergic receptors. *J Invest Dermatol Symp Proc* 2: 41–48, 1997.
221. Grando SA, Crosby AM, Zelickson BD, and Dahl MV. Agarose gel keratinocyte outgrowth system as a model of skin re-epithelization: requirement of endogenous acetylcholine for outgrowth initiation. *J Invest Dermatol* 101: 804–810, 1993.
222. Grando SA and Horton RM. The keratinocyte cholinergic system with acetylcholine as an epidermal cytotransmitter. *Curr Opin Dermatol* 1997: 462–468, 1997.
223. Grando SA, Kist DA, Qi M, and Dahl MV. Human keratinocytes synthesize, secrete, and degrade acetylcholine. *J Invest Dermatol* 101: 32–36, 1993.
224. Granholm NH, Japs RA, and Kappenman KE. Differentiation of hairbulb pigment cell melanosomes in compound agouti and albino locus mouse mutants (Ay, a, c2J; C57BL/6J). *Pigment Cell Res* 3: 16–27, 1990.
225. Granholm NH and Van Amerongen AW. Effects of exogenous MSH on the transformation from phaeo- to eumelanogenesis within C57BL/6J-Ay/a hairbulb melanocytes. *J Invest Dermatol* 96: 78–84, 1991.
226. Greaves MW and Davies MG. Histamine receptors in human skin: indirect evidence. *Br J Dermatol* 107 Suppl 23: 101–105, 1982.
227. Green JP, Prell GD, Khandelwal JK, and Blandina P. Aspects of histamine metabolism. *Agents Actions* 22: 1–15, 1987.
228. Green S, Walter P, Kumar V, Krust A, Bornert JM, Argos P, and Chambon P. Human oestrogen receptor cDNA: sequence, expression and homology to v-erb-A. *Nature* 320: 134–139, 1986.
229. Greene GL, Gilna P, Waterfield M, Baker A, Hort Y, and Shine J. Sequence and expression of human estrogen receptor complementary DNA. *Science* 231: 1150–1154, 1986.
230. Grichnik JM, Ali WN, Burch JA, Byers JD, Garcia CA, Clark RE, and Shea CR. KIT expression reveals a population of precursor melanocytes in human skin. *J Invest Dermatol* 106: 967–971, 1996.
231. Grichnik JM, Crawford J, Jimenez F, Kurtzberg J, Buchanan M, Blackwell S, Clark RE, and Hitchcock MG. Human recombinant stem-cell factor induces melanocytic hyperplasia in susceptible patients. *J Am Acad Dermatol* 33: 577–583, 1995.
232. Griffiths CE, Kang S, Ellis CN, Kim KJ, Finkel LJ, Ortiz-Ferrer LC, White GM, Hamilton TA, and Voorhees JJ. Two concentrations of topical tretinoin (retinoic acid) cause similar improvement of photoaging but different degrees of irritation. A double-blind, vehicle-controlled comparison of 0.1% and 0.025% tretinoin creams. *Arch Dermatol* 131: 1037–1044, 1995.
233. Grimaldi P, Rossi P, Dolci S, Ripamonti CB, and Geremia R. Molecular genetics of male infertility: stem cell factor/*c-kit* system. *Am J Reprod Immunol* 48: 27–33, 2002.

234. **Groene D, Martus P, and Heyer G.** Doxepin affects acetylcholine induced cutaneous reactions in atopic eczema. *Exp Dermatol* 10: 110–117, 2001.
235. **Gruber JR, Ohno S, and Niles RM.** Increased expression of protein kinase C alpha plays a key role in retinoic acid-induced melanoma differentiation. *J Biol Chem* 267: 13356–13360, 1992.
236. **Gunn TM, Miller KA, He L, Hyman RW, Davis RW, Azarani A, Schlossman SF, Duke-Cohan JS, and Barsh GS.** The mouse mahogany locus encodes a transmembrane form of human attractin. *Nature* 398: 152–156, 1999.
237. **Haak-Frendscho M, Darvas Z, Hegyesi H, Karpati S, Hoffman RL, Laszlo V, Bencsath M, Szalai C, Furesz J, Timar J, Bata-Csorgo Z, Szabad G, Pivarcsi A, Pallinger E, Kemeny L, Horvath A, Dobozy A, and Falus A.** Histidine decarboxylase expression in human melanoma. *J Invest Dermatol* 115: 345–352, 2000.
238. **Haase E, Ito S, and Wakamatsu K.** Influences of sex, castration, and androgens on the eumelanin and pheomelanin contents of different feathers in wild mallards. *Pigment Cell Res* 8: 164–170, 1995.
239. **Hachiya A, Kobayashi T, Takema Y, and Imokawa G.** Biochemical characterization of endothelin-converting enzyme-1alpha in cultured skin-derived cells and its postulated role in the stimulation of melanogenesis in human epidermis. *J Biol Chem* 277: 5395–5403, 2002.
240. **Haddad MM, Xu W, and Medrano EE.** Aging in epidermal melanocytes: cell cycle genes and melanins. *J Invest Dermatol Symp Proc* 3: 36–40, 1998.
241. **Haddad MM, Xu W, Schwahn DJ, Liao F, and Medrano EE.** Activation of a cAMP pathway and induction of melanogenesis correlate with association of p16(INK4) and p27(KIP1) to CDKs, loss of E2F-binding activity, and premature senescence of human melanocytes. *Exp Cell Res* 253: 561–572, 1999.
242. **Hadley M.** *Endocrinology*. Englewood Cliffs, NJ: Prentice Hall, 1996.
243. **Halaban R.** The regulation of normal melanocyte proliferation. *Pigment Cell Res* 13: 4–14, 2000.
244. **Halaban R.** Pigmentation in melanomas: changes manifesting underlying oncogenic and metabolic activities. *Oncol Res* 13: 3–8, 2002.
245. **Halaban R, Bohm M, Dotto P, Moellmann G, Cheng E, and Zhang Y.** Growth regulatory proteins that repress differentiation markers in melanocytes also downregulate the transcription factor microphthalmia. *J Invest Dermatol* 106: 1266–1272, 1996.
246. **Halaban R, Cheng E, and Hebert DN.** Coexpression of wild-type tyrosinase enhances maturation of temperature-sensitive tyrosinase mutants. *J Invest Dermatol* 119: 481–488, 2002.
247. **Halaban R, Cheng E, Svedine S, Aron R, and Hebert DN.** Proper folding and endoplasmic reticulum to Golgi transport of tyrosinase are induced by its substrates, DOPA and tyrosine. *J Biol Chem* 276: 11933–11938, 2001.
248. **Halaban R, Cheng E, Zhang Y, Moellmann G, Hanlon D, Michalak M, Setaluri V, and Hebert DN.** Aberrant retention of tyrosinase in the endoplasmic reticulum mediates accelerated degradation of the enzyme and contributes to the dedifferentiated phenotype of amelanotic melanoma cells. *Proc Natl Acad Sci USA* 94: 6210–6215, 1997.
249. **Halaban R, Patton RS, Cheng E, Svedine S, Trombetta ES, Wahl ML, Ariyan S, and Hebert DN.** Abnormal acidification of melanoma cells induces tyrosinase retention in the early secretory pathway. *J Biol Chem* 277: 14821–14828, 2002.
250. **Halaban R, Svedine S, Cheng E, Smicun Y, Aron R, and Hebert DN.** Endoplasmic reticulum retention is a common defect associated with tyrosinase-negative albinism. *Proc Natl Acad Sci USA* 97: 5889–5894, 2000.
251. **Hale LP.** Zinc alpha-2-glycoprotein regulates melanin production by normal and malignant melanocytes. *J Invest Dermatol* 119: 464–470, 2002.
252. **Hall JM, Couse JF, and Korach KS.** The multifaceted mechanisms of estradiol and estrogen receptor signaling. *J Biol Chem* 276: 36869–36872, 2001.
253. **Hamilton JB.** Influence of the endocrine status upon pigmentation in man and in mammals. *Ann NY Acad Sci* 341–357, 1938.
254. **Hanin P and Vachtenheim J.** Tyrosinase protein is expressed also in some neural crest derived cells which are not melanocytes. *Pigment Cell Res* 1: 340–343, 1988.
255. **Hann SK and Nordlund JJ.** *Vitiligo*. Malden, MA: Blackwell Science, 2000.
256. **Hansen CM, Madsen MW, Arensbak B, Skak-Nielsen T, Latini S, and Binderup L.** Down-regulation of laminin-binding integrins by 1 alpha,25-dihydroxyvitamin D₃ in human melanoma cells in vitro. *Cell Adhes Commun* 5: 109–120, 1998.
257. **Hara M, Yaar M, Byers HR, Goukassian D, Fine RE, Gonsalves J, and Gilchrist BA.** Kinesin participates in melanosomal movement along melanocyte dendrites. *J Invest Dermatol* 114: 438–443, 2000.
258. **Hara M, Yaar M, and Gilchrist BA.** Endothelin-1 of keratinocyte origin is a mediator of melanocyte dendricity. *J Invest Dermatol* 105: 744–748, 1995.
259. **Hashimoto K.** The ultrastructure of the skin of human embryos. 8. Melanoblast and intrafollicular melanocyte. *J Anat* 108: 99–108, 1971.
260. **He L, Gunn TM, Bouley DM, Lu XY, Watson SJ, Schlossman SF, Duke-Cohan JS, and Barsh GS.** A biochemical function for attractin in agouti-induced pigmentation and obesity. *Nat Genet* 27: 40–47, 2001.
261. **He L, Lu XY, Jolly AF, Eldridge AG, Watson SJ, Jackson PK, Barsh GS, and Gunn TM.** Spongiform degeneration in mahogany mutant mice. *Science* 299: 710–712, 2003.
262. **Hearing V.** The melanosome: the perfect model for cellular responses to the environment. *Pigment Cell Res* 13: 23–34, 2000.
263. **Hearing VJ.** Biochemical control of melanogenesis and melanosomal organization. *J Invest Dermatol Symp Proc* 4: 24–28, 1999.
264. **Hearing VJ and Tsukamoto K.** Enzymatic control of pigmentation in mammals. *FASEB J* 5: 2902–2909, 1991.
265. **Hegyesi H, Somlai B, Varga VL, Toth G, Kovacs P, Molnar EL, Laszlo V, Karpati S, Rivera E, Falus A, and Darvas Z.** Suppression of melanoma cell proliferation by histidine decarboxylase specific antisense oligonucleotides. *J Invest Dermatol* 117: 151–153, 2001.
266. **Henderson DJ and Copp AJ.** Role of the extracellular matrix in neural crest cell migration. *J Anat* 191: 507–515, 1997.
267. **Henderson JB, Dunnigan MG, McIntosh WB, Abdul-Motaal AA, Gettinby G, and Glekin BM.** The importance of limited exposure to ultraviolet radiation and dietary factors in the aetiology of Asian rickets: a risk-factor model. *Q J Med* 63: 413–425, 1987.
268. **Herbarth B, Pingault V, Bondurand N, Kuhlbrodt K, Hermans-Borgmeyer I, Puliti A, Lemort N, Goossens M, and Wegner M.** Mutation of the Sry-related *Sox10* gene in Dominant megacolon, a mouse model for human Hirschsprung disease. *Proc Natl Acad Sci USA* 95: 5161–5165, 1998.
269. **Herndon LW, Robert DW, Wand M, and Asrani S.** Increased periocular pigmentation with ocular hypotensive lipid use in African Americans. *Am J Ophthalmol* 135: 713–715, 2003.
270. **Hierro FR, Orus A, Corretger JM, Ballesta F, and Cruz M.** [Male pseudohermaphroditism due to deficit in the conversion of cholesterol to delta⁵ pregnenolone (author's transl)]. *An Esp Pediatr* 12: 329–336, 1979.
271. **Higashi Y, Asanuma M, Miyazaki I, and Ogawa N.** Inhibition of tyrosinase reduces cell viability in catecholaminergic neuronal cells. *J Neurochem* 75: 1771–1774, 2000.
272. **Hill J, Duckworth M, Murdock P, Rennie G, Sabido-David C, Ames RS, Szekeres P, Wilson S, Bergsma DJ, Gloger IS, Levy DS, Chambers JK, and Muir AI.** Molecular cloning and functional characterization of MCH2, a novel human MCH receptor. *J Biol Chem* 276: 20125–20129, 2001.
273. **Hill SJ.** Distribution, properties, and functional characteristics of three classes of histamine receptor. *Pharmacol Rev* 42: 45–83, 1990.
274. **Hill SJ, Ganellin CR, Timmerman H, Schwartz JC, Shankley NP, Young JM, Schunack W, Levi R, and Haas HL.** International Union of Pharmacology. XIII. Classification of histamine receptors. *Pharmacol Rev* 49: 253–278, 1997.
275. **Hirai Y, Nose A, Kobayashi S, and Takeichi M.** Expression and role of E- and P-cadherin adhesion molecules in embryonic histogenesis. II. Skin morphogenesis. *Development* 105: 271–277, 1989.

276. **Hirano T, Ishihara K, and Hibi M.** Roles of STAT3 in mediating the cell growth, differentiation and survival signals relayed through the IL-6 family of cytokine receptors. *Oncogene* 19: 2548–2556, 2000.
277. **Hirobe T.** Melanocyte stimulating hormone induces the differentiation of mouse epidermal melanocytes in serum-free culture. *J Cell Physiol* 152: 337–345, 1992.
278. **Hirobe T.** Hydrocortisone is involved in regulating the proliferation and differentiation of mouse epidermal melanoblasts in serum-free culture in the presence of keratinocytes. *Eur J Cell Biol* 71: 387–394, 1996.
279. **Hirobe T.** Endothelins are involved in regulating the proliferation and differentiation of mouse epidermal melanocytes in serum-free primary culture. *J Invest Dermatol Symp Proc* 6: 25–31, 2001.
280. **Hirobe T, Wakamatsu K, Ito S, Abe H, Kawa Y, and Mizoguchi M.** Stimulation of the proliferation and differentiation of mouse pink-eyed dilution epidermal melanocytes by excess tyrosine in serum-free primary culture. *J Cell Physiol* 191: 162–172, 2002.
281. **Hirsch E, Graybiel AM, and Agid YA.** Melanized dopaminergic neurons are differentially susceptible to degeneration in Parkinson's disease. *Nature* 334: 345–348, 1988.
282. **Ho KJ and Liao JK.** Nonnuclear actions of estrogen. *Arterioscler Thromb Vasc Biol* 22: 1952–1961, 2002.
283. **Holbrook KA, Underwood RA, Vogel AM, Gown AM, and Kimball H.** The appearance, density and distribution of melanocytes in human embryonic and fetal skin revealed by the anti-melanoma monoclonal antibody, HMB-45. *Anat Embryol* 180: 443–455, 1989.
284. **Holick MF.** Noncalcemic actions of 1,25-dihydroxyvitamin D₃ and clinical applications. *Bone* 17: 107S–111S, 1995.
285. **Hoogduijn MJ, Ancans J, Suzuki I, Estdale S, and Thody AJ.** Melanin-concentrating hormone and its receptor are expressed and functional in human skin. *Biochem Biophys Res Commun* 296: 698–701, 2002.
286. **Hoogduijn MJ, Ancans J, and Thody AJ.** Melanin-concentrating hormone may act as a paracrine inhibitor of melanogenesis. *Br J Dermatol* 144: 651–677, 2001.
287. **Horikawa T, Norris DA, Johnson TW, Zekman T, Dunscomb N, Bennion SD, Jackson RL, and Morelli JG.** DOPA-negative melanocytes in the outer root sheath of human hair follicles express premelanosomal antigens but not a melanosomal antigen or the melanosome-associated glycoproteins tyrosinase, TRP-1, and TRP-2. *J Invest Dermatol* 106: 28–35, 1996.
288. **Hosoda K, Hammer RE, Richardson JA, Baynash AG, Cheung JC, Giaid A, and Yanagisawa M.** Targeted and natural (piebald-lethal) mutations of endothelin-B receptor gene produce megacolon associated with spotted coat color in mice. *Cell* 79: 1267–1276, 1994.
289. **Hosoi J, Abe E, Suda T, and Kuroki T.** Regulation of melanin synthesis of B16 mouse melanoma cells by 1 alpha,25-dihydroxyvitamin D₃ and retinoic acid. *Cancer Res* 45: 1474–1478, 1985.
290. **Hoth CF, Milunsky A, Lipsky N, Sheffer R, Clarren SK, and Baldwin CT.** Mutations in the paired domain of the human PAX3 gene cause Klein-Waardenburg syndrome (WS-III) as well as Waardenburg syndrome type I (WS-I). *Am J Hum Genet* 52: 455–462, 1993.
291. **Hou L, Panthier JJ, and Arnheiter H.** Signaling and transcriptional regulation in the neural crest-derived melanocyte lineage: interactions between KIT and MITF. *Development* 127: 5379–5389, 2000.
292. **Houghton AN, Thomson TM, Gross D, Oettgen HF, and Old LJ.** Surface antigens of melanoma and melanocytes. Specificity of induction of Ia antigens by human gamma-interferon. *J Exp Med* 160: 255–269, 1984.
293. **Howe J, Costantino R, and Slominski A.** On the putative mechanism of induction and regulation of melanogenesis by L-tyrosine. *Acta Derm Venereol* 71: 150–152, 1991.
294. **Howell WM, Turner SJ, Collins A, Bateman AC, and Theaker JM.** Influence of TNFalpha and LTalpha single nucleotide polymorphisms on susceptibility to and prognosis in cutaneous malignant melanoma in the British population. *Eur J Immunogenet* 29: 17–23, 2002.
295. **Hsu MY, Meier FE, Nesbit M, Hsu JY, Van Belle P, Elder DE, and Herlyn M.** E-cadherin expression in melanoma cells restores keratinocyte-mediated growth control and down-regulates expression of invasion-related adhesion receptors. *Am J Pathol* 156: 1515–1525, 2000.
296. **Hsueh EC, Gupta RK, Lefor A, Reyzin G, Ye W, and Morton DL.** Androgen blockade enhances response to melanoma vaccine. *J Surg Res* 110: 393–398, 2003.
297. **Hu DN.** Regulation of growth and melanogenesis of uveal melanocytes. *Pigment Cell Res* 13 Suppl 8: 81–86, 2000.
298. **Hu DN, McCormick SA, and Roberts JE.** Effects of melatonin, its precursors and derivatives on the growth of cultured human uveal melanoma cells. *Melanoma Res* 8: 205–210, 1998.
299. **Hu DN and Roberts JE.** Melatonin inhibits growth of cultured human uveal melanoma cells. *Melanoma Res* 7: 27–31, 1997.
300. **Huang S, Jean D, Luca M, Tainsky MA, and Bar-Eli M.** Loss of AP-2 results in downregulation of c-KIT and enhancement of melanoma tumorigenicity and metastasis. *EMBO J* 17: 4358–4369, 1998.
301. **Huang S, Luca M, Gutman M, McConkey DJ, Langley KE, Lyman SD, and Bar-Eli M.** Enforced c-KIT expression renders highly metastatic human melanoma cells susceptible to stem cell factor-induced apoptosis and inhibits their tumorigenic and metastatic potential. *Oncogene* 13: 2339–2347, 1996.
302. **Huffnagle GB, Strieter RM, Standiford TJ, McDonald RA, Burdick MD, Kunkel SL, and Toews GB.** The role of monocyte chemoattractant protein-1 (MCP-1) in the recruitment of monocytes and CD4+ T cells during a pulmonary *Cryptococcus neoformans* infection. *J Immunol* 155: 4790–4797, 1995.
303. **Hunt G.** Melanocyte-stimulating hormone: a regulator of human melanocyte physiology. *Pathobiology* 63: 12–21, 1995.
304. **Hunt G, Donatien PD, Lunec J, Todd C, Kyne S, and Thody AJ.** Cultured human melanocytes respond to MSH peptides and ACTH. *Pigment Cell Res* 7: 217–221, 1994.
305. **Hunt G and Thody AJ.** Agouti protein can act independently of melanocyte-stimulating hormone to inhibit melanogenesis. *J Endocrinol* 147: R1–R4, 1995.
306. **Hunt G, Todd C, Cresswell JE, and Thody AJ.** Alpha-melanocyte stimulating hormone and its analogue Nle4Dphe7 alpha-MSH affect morphology, tyrosinase activity and melanogenesis in cultured human melanocytes. *J Cell Sci* 107: 205–211, 1994.
307. **Hunt G, Todd C, Kyne S, and Thody AJ.** ACTH stimulates melanogenesis in cultured human melanocytes. *J Endocrinol* 140: R1–R3, 1994.
308. **Huszar D, Lynch CA, Fairchild-Huntress V, Dunmore JH, Fang Q, Berkemeier LR, Gu W, Kesterson RA, Boston BA, Cone RD, Smith FJ, Campfield LA, Burn P, and Lee F.** Targeted disruption of the melanocortin-4 receptor results in obesity in mice. *Cell* 88: 131–141, 1997.
309. **Hutchinson PE, Osborne JE, Lear JT, Smith AG, Bowers PW, Morris PN, Jones PW, York C, Strange RC, and Fryer AA.** Vitamin D receptor polymorphisms are associated with altered prognosis in patients with malignant melanoma. *Clin Cancer Res* 6: 498–504, 2000.
310. **Ichihashi M, Funasaka Y, Ohashi A, Chacraborty A, Ahmed NU, Ueda M, and Osawa T.** The inhibitory effect of DL-alpha-tocopherol ferulate in lecithin on melanogenesis. *Anticancer Res* 19: 3769–3774, 1999.
311. **Im S, Lee ES, Kim W, On W, Kim J, Lee M, and Kang WH.** Donor specific response of estrogen and progesterone on cultured human melanocytes. *J Korean Med Sci* 17: 58–64, 2002.
312. **Imagawa M, Chiu R, and Karin M.** Transcription factor AP-2 mediates induction by two different signal-transduction pathways: protein kinase C and cAMP. *Cell* 51: 251–260, 1987.
313. **Imokawa G, Miyagishi M, and Yada Y.** Endothelin-1 as a new melanogen: coordinated expression of its gene and the tyrosinase gene in UVB-exposed human epidermis. *J Invest Dermatol* 105: 32–37, 1995.
314. **Imokawa G, Yada Y, and Kimura M.** Signalling mechanisms of endothelin-induced mitogenesis and melanogenesis in human melanocytes. *Biochem J* 314: 305–312, 1996.
315. **Imokawa G, Yada Y, and Miyagishi M.** Endothelins secreted from human keratinocytes are intrinsic mitogens for human melanocytes. *J Biol Chem* 267: 24675–24680, 1992.

316. **Inazu M and Mishima Y.** Detection of eumelanogenic and pheomelanogenic melanosomes in the same normal human melanocyte. *J Invest Dermatol* 100: 172S–175S, 1993.
317. **Inoue A, Yanagisawa M, Kimura S, Kasuya Y, Miyauchi T, Goto K, and Masaki T.** The human endothelin family: three structurally and pharmacologically distinct isopeptides predicted by three separate genes. *Proc Natl Acad Sci USA* 86: 2863–2867, 1989.
318. **Iozumi K, Hoganson GE, Pennella R, Everett MA, and Fuller BB.** Role of tyrosinase as the determinant of pigmentation in cultured human melanocytes. *J Invest Dermatol* 100: 806–811, 1993.
319. **Ito A, Tanaka C, Takeuchi T, and Mishima Y.** Glucocorticoid stimulates melanogenesis and tyrosinase gene expression in B16 melanoma cells. *Pigment Cell Res* 4: 247–251, 1991.
320. **Ito D, Back TC, Shakhov AN, Wiltrout RH, and Nedospasov SA.** Mice with a targeted mutation in lymphotoxin- α exhibit enhanced tumor growth and metastasis: impaired NK cell development and recruitment. *J Immunol* 163: 2809–2815, 1999.
321. **Ito K, Sato S, Takahashi M, Uesugi T, Shinozima H, and Kukita A.** Melanocytes observed in the human sebaceous gland. *Jpn J Clin Dermatol* 28: 113–117, 1974.
322. **Ito M, Kawa Y, Ono H, Okura M, Baba T, Kubota Y, Nishikawa SI, and Mizoguchi M.** Removal of stem cell factor or addition of monoclonal anti-c-KIT antibody induces apoptosis in murine melanocyte precursors. *J Invest Dermatol* 112: 796–801, 1999.
323. **Ito S.** The IFPCS presidential lecture: a chemist's view of melanogenesis. *Pigment Cell Res* 16: 230–236, 2003.
324. **Iwata M, Corn T, Iwata S, Everett MA, and Fuller BB.** The relationship between tyrosinase activity and skin color in human foreskins. *J Invest Dermatol* 95: 9–15, 1990.
325. **Iwata M, Iwata S, Everett MA, and Fuller BB.** Hormonal stimulation of tyrosinase activity in human foreskin organ cultures. *In Vitro Cell Dev Biol* 26: 554–560, 1990.
326. **Iyengar B.** Modulation of melanocytic activity by acetylcholine. *Acta Anat* 136: 139–141, 1989.
327. **Iyengar B and Misra RS.** Reaction of dendritic melanocytes in vitiligo to the substrates of tyrosine metabolism. *Acta Anat* 129: 203–205, 1987.
328. **Jackson IJ.** Molecular and developmental genetics of mouse coat color. *Annu Rev Genet* 28: 189–217, 1994.
329. **Jackson IJ, Chambers DM, Budd PS, and Johnson R.** The tyrosinase-related protein-1 gene has a structure and promoter sequence very different from tyrosinase. *Nucleic Acids Res* 19: 3799–3804, 1991.
330. **Jackson IJ, Chambers DM, Tsukamoto K, Copeland NG, Gilbert DJ, Jenkins NA, and Hearing V.** A second tyrosinase-related protein, TRP-2, maps to and is mutated at the mouse slaty locus. *EMBO J* 11: 527–535, 1992.
331. **Jee SH, Lee SY, Chiu HC, Chang CC, and Chen TJ.** Effects of estrogen and estrogen receptor in normal human melanocytes. *Biochem Biophys Res Commun* 199: 1407–1412, 1994.
332. **Jenster G, van der Korput HA, Trapman J, and Brinkmann AO.** Identification of two transcription activation units in the N-terminal domain of the human androgen receptor. *J Biol Chem* 270: 7341–7346, 1995.
333. **Jimbow K, Hua C, Gomez P, Hirosaki K, Shinoda K, Salopek T, Matsusaka H, Jin HY, and Yamashita T.** Intracellular vesicular trafficking of tyrosinase gene family protein in eu- and pheomelanosome biogenesis. *Pigment Cell Res* 8: 110–117, 2000.
334. **Jimbow K, Miyake Y, Homma K, Yasuda K, Izumi Y, Tsutsumi A, and Ito S.** Characterization of melanogenesis and morphogenesis of melanosomes by physicochemical properties of melanin and melanosomes in malignant melanoma. *Cancer Res* 44: 1128–1134, 1984.
335. **Jimbow K, Park J, Kato F, Hirosaki K, Toyofuku K, Hua C, and Yamashita T.** Assembly, target-signaling and the intracellular transport of tyrosinase gene family proteins in the initial stages of melanosome biogenesis. *Pigment Cell Res* 13: 222–229, 2000.
336. **Jimenez-Cervantes C, Solano F, Kobayashi T, Urabe K, Hearing VJ, Lozano JA, and Garcia-Borrón JC.** A new enzymatic function in the melanogenic pathway. The 5,6-dihydroxyindole-2-carboxylic acid oxidase activity of tyrosinase-related protein-1 (TRP1). *J Biol Chem* 269: 17993–18000, 1994.
337. **Jin EJ, Erickson CA, Takada S, and Burrus LW.** Wnt and BMP signaling govern lineage segregation of melanocytes in the avian embryo. *Dev Biol* 233: 22–37, 2001.
338. **Johansson O and Wang L.** Choline acetyltransferase-like immunofluorescence in epidermis of human skin. *Neurobiology* 1: 201–206, 1993.
339. **Johnson R and Jackson IJ.** Light is a dominant mouse mutation resulting in premature cell death. *Nat Genet* 1: 226–229, 1992.
340. **Jordan SA and Jackson IJ.** MGF (KIT ligand) is a chemokine factor for melanoblast migration into hair follicles. *Dev Biol* 225: 424–436, 2000.
341. **Juhlin L.** Localization and content of histamine in normal and diseased skin. *Acta Derm Venereol* 47: 383–391, 1967.
342. **Kadono S, Manaka I, Kawashima M, Kobayashi T, and Imokawa G.** The role of the epidermal endothelin cascade in the hyperpigmentation mechanism of lentigo senilis. *J Invest Dermatol* 116: 571–577, 2001.
343. **Kamaraju AK, Bertolotto C, Chebath J, and Revel M.** Pax3 down-regulation and shut-off of melanogenesis in melanoma B16/F10.9 by interleukin-6 receptor signaling. *J Biol Chem* 277: 15132–15141, 2002.
344. **Kameyama K, Jimenez M, Muller J, Ishida Y, and Hearing VJ.** Regulation of mammalian melanogenesis by tyrosinase inhibition. *Differentiation* 42: 28–36, 1989.
345. **Kameyama K, Tanaka S, Ishida Y, and Hearing VJ.** Interferons modulate the expression of hormone receptors on the surface of murine melanoma cells. *J Clin Invest* 83: 213–221, 1989.
346. **Kang S, Li XY, and Voorhees JJ.** Pharmacology and molecular action of retinoids and vitamin D in skin. *J Invest Dermatol Symp Proc* 1: 15–21, 1996.
347. **Karbownik M, Lewinski A, and Reiter RJ.** Anticarcinogenic actions of melatonin which involve antioxidative processes: comparison with other antioxidants. *Int J Biochem* 33: 735–753, 2001.
348. **Kauser S, Schallreuter KU, Thody AJ, Gummer C, and Tobin DJ.** Regulation of human epidermal melanocyte biology by beta-endorphin. *J Invest Dermatol* 120: 1073–1080, 2003.
349. **Kavanagh GM, Sabroe RA, Greaves MW, and Archer CB.** The intradermal effects of the H3 receptor agonist R alpha methylhistamine in human skin. *Br J Dermatol* 138: 622–626, 1998.
350. **Kawauchi H, Kawazoe I, Tsubokawa M, Kishida M, and Baker BI.** Characterization of melanin-concentrating hormone in chum salmon pituitaries. *Nature* 305: 321–323, 1983.
351. **Kelsall SR, Le Fur N, and Mintz B.** Qualitative and quantitative catalog of tyrosinase alternative transcripts in normal murine skin melanocytes as a basis for detecting melanoma-specific changes. *Biochem Biophys Res Commun* 236: 173–177, 1997.
352. **Kema IP, de Vries EGE, and Muskiet FAJ.** Clinical chemistry of serotonin and metabolites. *J Chromatogr B* 747: 33–48, 2000.
353. **Kemp EH, Waterman EA, Hawes BE, O'Neill K, Gottumukkala RV, Gawkrödger DJ, Weetman AP, and Watson PF.** The melanin-concentrating hormone receptor 1, a novel target of autoantibody responses in vitiligo. *J Clin Invest* 109: 923–930, 2002.
354. **Kesterson RA, Huszar D, Lynch CA, Simerly RB, and Cone RD.** Induction of neuropeptide Y gene expression in the dorsal medial hypothalamic nucleus in two models of the agouti obesity syndrome. *Mol Endocrinol* 11: 630–637, 1997.
355. **Khare VK, Albino AP, and Reed JA.** The neuropeptide/mast cell secretagogue substance P is expressed in cutaneous melanocytic lesions. *J Cutan Pathol* 25: 2–10, 1998.
356. **Khong HT and Rosenberg SA.** Pre-existing immunity to tyrosinase-related protein (TRP)-2, a new TRP-2 isoform, and the NY-ESO-1 melanoma antigen in a patient with a dramatic response to immunotherapy. *J Immunol* 168: 951–956, 2002.
357. **Kieffer BL.** Recent advances in molecular recognition and signal transduction of active peptides: receptors for opioid peptides. *Cell Mol Neurobiol* 15: 615–635, 1995.
358. **Kikuchi H, Miura H, Yamamoto H, Takeuchi T, Dei T, and Watanabe M.** Characteristic sequences in the upstream region of the human tyrosinase gene. *Biochim Biophys Acta* 1009: 283–286, 1989.

359. Kilgus O, Payer E, Schreiber S, Elbe A, Strohal R, and Stingl G. In vivo cytokine expression in normal and perturbed murine skin—analysis by competitive quantitative polymerase chain reaction. *J Invest Dermatol* 100: 674–680, 1993.
360. Kim DS, Kim SY, Chung JH, Kim KH, Eun HC, and Park KC. Delayed ERK activation by ceramide reduces melanin synthesis in human melanocytes. *Cell Signal* 14: 779–785, 2002.
361. Kippenberger S, Loitsch S, Solano F, Bernd A, and Kaufmann R. Quantification of tyrosinase, TRP-1, and Trp-2 transcripts in human melanocytes by reverse transcriptase-competitive multiplex PCR—regulation by steroid hormones. *J Invest Dermatol* 110: 364–367, 1998.
362. Kirnbauer R, Charvat B, Schauer E, Kock A, Urbanski A, Forster E, Neuner P, Assmann I, Luger TA, and Schwarz T. Modulation of intercellular adhesion molecule-1 expression on human melanocytes and melanoma cells: evidence for a regulatory role of IL-6, IL-7, TNF beta, and UVB light. *J Invest Dermatol* 98: 320–326, 1992.
363. Kligman AM. The human hair cycle. *J Invest Dermatol* 33: 307–316, 1959.
364. Kligman AM and Willis I. A new formula for depigmenting human skin. *Arch Dermatol* 111: 40–48, 1975.
365. Kline EL, Carland K, and Smith TJ. Triiodothyronine repression of imidazole-induced tyrosinase expression in B16 melanoma cells. *Endocrinology* 119: 2118–2123, 1986.
366. Kline EL, Carland KC, Warren JT Jr, and Smith TJ. Effect of testosterone on imidazole-induced tyrosinase expression in B16 melanoma cell culture. *Cancer Res* 48: 3586–3590, 1988.
367. Knock GA, Terenghi G, Bunker CB, Bull HA, Dowd PM, and Polak JM. Characterization of endothelin-binding sites in human skin and their regulation in primary Raynaud's phenomenon and systemic sclerosis. *J Invest Dermatol* 101: 73–78, 1993.
368. Kobayashi T, Urabe K, Winder A, Jimenez-Cervantes C, Imokawa G, Brewington T, Solano F, Garcia-Borrón JC, and Hearing VJ. Tyrosinase related protein 1 (TRP1) functions as a DHICA oxidase in melanin biosynthesis. *EMBO J* 13: 5818–5825, 1994.
369. Kohn FM, Ring J, and Schill WB. Dermatologic aspects of male hypogonadism. *Hautarzt* 51: 223–230, 2000.
370. Kokelj F, Lavaroni G, Perkan V, and Plozzer C. Hyperpigmentation due to calcipotriol (MC 903) plus heliotherapy in psoriatic patients. Three case reports. *Acta Derm Venereol* 75: 307–309, 1995.
371. Kondo S. The roles of cytokines in photoaging. *J Dermatol Sci* 23 Suppl 1: S30–S36, 2000.
372. Koranda FC. Antimalarials. *J Am Acad Dermatol* 4: 650–655, 1981.
373. Korner A and Pawelek J. Activation of melanoma tyrosinase by a cyclic AMP-dependent protein kinase in a cell-free system. *Nature* 267: 444–447, 1977.
374. Korner A and Pawelek J. Mammalian tyrosinase catalyzes three reactions in the biosynthesis of melanin. *Science* 217: 1163–1165, 1982.
375. Kotani M, Tanaka I, Ogawa Y, Usui T, Mori K, Ichikawa A, Narumiya S, Yoshimi T, and Nakao K. Molecular cloning and expression of multiple isoforms of human prostaglandin E receptor EP3 subtype generated by alternative messenger RNA splicing: multiple second messenger systems and tissue-specific distributions. *Mol Pharmacol* 48: 869–879, 1995.
376. Kousteni S, Bellido T, Plotkin LI, O'Brien CA, Bodenner DL, Han L, Han K, DiGregorio GB, Katzenellenbogen JA, Katzenellenbogen BS, Roberson PK, Weinstein RS, Jilka RL, and Manolagas SC. Nongenotropic, sex-nonspecific signaling through the estrogen or androgen receptors: dissociation from transcriptional activity. *Cell* 104: 719–730, 2001.
377. Kozłowski M, Larose L, Lee F, Le DM, Rottapel R, and Siminovitch KA. SHP-1 binds and negatively modulates the c-Kit receptor by interaction with tyrosine 569 in the c-Kit juxtamembrane domain. *Mol Cell Biol* 18: 2089–2099, 1998.
378. Kozyreva TV, Tkachenko EY, Kozaruk VP, Latysheva TV, and Gilinsky MA. Effects of slow and rapid cooling on catecholamine concentration in arterial plasma and the skin. *Am J Physiol Regul Integr Comp Physiol* 276: R1668–R1672, 1999.
379. Krasagakis K, Garbe C, Eberle J, and Orfanos CE. Tumor necrosis factors and several interleukins inhibit the growth and modulate the antigen expression of normal human melanocytes in vitro. *Arch Dermatol Res* 287: 259–265, 1995.
380. Kunisada T, Lu SZ, Yoshida H, Nishikawa S, Mizoguchi M, Hayashi S, Tyrrell L, Williams DA, Wang X, and Longley BJ. Murine cutaneous mastocytosis and epidermal melanocytosis induced by keratinocyte expression of transgenic stem cell factor. *J Exp Med* 187: 1565–1573, 1998.
381. Kunisada T, Yamazaki H, Hirobe T, Kamei S, Omoteno M, Tagaya H, Hemmi H, Koshimizu U, Nakamura T, and Hayashi SI. Keratinocyte expression of transgenic hepatocyte growth factor affects melanocyte development, leading to dermal melanocytosis. *Mech Dev* 94: 67–78, 2000.
382. Kupperman HS. Hormone control of a dimorphic pigmentation area in the golden hamster (*Cricetus auratus*). *Anat Rec* 88: 26, 1944.
383. Kurihara Y, Kurihara H, Oda H, Maemura K, Nagai R, Ishikawa T, and Yazaki Y. Aortic arch malformations and ventricular septal defect in mice deficient in endothelin-1. *J Clin Invest* 96: 293–300, 1995.
384. Kushimoto T, Basrur V, Valencia J, Matsunaga J, Vieira WD, Ferrans VJ, Muller J, Appella E, and Hearing VJ. A model for melanosome biogenesis based on the purification and analysis of early melanosomes. *Proc Natl Acad Sci USA* 98: 10698–10703, 2001.
385. Kushimoto T, Valencia JC, Costin GE, Toyofuku K, Watabe H, Yasumoto K, Rouzaud F, Vieira WD, and Hearing VJ. The melanosome: an ideal model to study cellular differentiation. *Pigment Cell Res* 16: 237–244, 2003.
386. Kutsch CL, Norris DA, and Arend WP. Tumor necrosis factor-alpha induces interleukin-1 alpha and interleukin-1 receptor antagonist production by cultured human keratinocytes. *J Invest Dermatol* 101: 79–85, 1993.
387. Kwon BS. Pigmentation genes: the tyrosinase gene family and the pmel 17 gene family. *J Invest Dermatol* 100: 134S–140S, 1993.
388. Kwon BS, Chintamaneni C, Kozak CA, Copeland NG, Gilbert DJ, Jenkins N, Barton D, Francke U, Kobayashi Y, and Kim KK. A melanocyte-specific gene, Pmel 17, maps near the silver coat color locus on mouse chromosome 10 and is in a syntenic region on human chromosome 12. *Proc Natl Acad Sci USA* 88: 9228–9232, 1991.
389. Kwon BS, Haq AK, Pomerantz SH, and Halaban R. Isolation and sequence of a cDNA clone for human tyrosinase that maps at the mouse *c-albino* locus. *Proc Natl Acad Sci USA* 84: 7473–7477, 1987.
390. Kwon HY, Bultman SJ, Loffler C, Chen WJ, Furdon PJ, Powell JG, Usala AL, Wilkison W, Hansmann I, and Woychik RP. Molecular structure and chromosomal mapping of the human homolog of the agouti gene. *Proc Natl Acad Sci USA* 91: 9760–9764, 1994.
391. Labbe O, Desarnaud F, Eggerickx D, Vassart G, and Parmentier M. Molecular cloning of a mouse melanocortin 5 receptor gene widely expressed in peripheral tissues. *Biochemistry* 33: 4543–4549, 1994.
392. Lacy ME. Photon-electron coupling as a possible transducing mechanism in bioelectronic processes involving neuromelanin. *J Theor Biol* 111: 201–204, 1984.
393. Ladanyi A, Nagy JO, Jeney A, and Timar J. Cytokine sensitivity of metastatic human melanoma cell lines—simultaneous inhibition of proliferation and enhancement of gelatinase activity. *Pathol Oncol Res* 4: 108–114, 1998.
394. Lahav R, Dupin E, Lecoin L, Glavieux C, Champeval D, Ziller C, and Le Douarin NM. Endothelin 3 selectively promotes survival and proliferation of neural crest-derived glial and melanocytic precursors in vitro. *Proc Natl Acad Sci USA* 95: 14214–14219, 1998.
395. Lahav R, Lecoin L, Ziller C, Nataf V, Carnahan JF, Martin FH, and Le Douarin NM. Effect of the Steel gene product on melanogenesis in avian neural crest cell cultures. *Differentiation* 58: 133–139, 1994.
396. Lai CT and Yu PH. Dopamine- and L-beta-3,4-dihydroxyphenylalanine hydrochloride (L-Dopa)-induced cytotoxicity towards catecholaminergic neuroblastoma SH-SY5Y cells. Effects of oxidative

- stress and antioxidative factors. *Biochem Pharmacol* 53: 363–372, 1997.
397. **Lakshmi MS, Parker C, and Sherbet GV.** Metastasis associated MTS1 and NM23 genes affect tubulin polymerisation in B16 melanomas: a possible mechanism of their regulation of metastatic behaviour of tumours. *Anticancer Res* 13: 299–303, 1993.
 398. **Lambert J, Vancoillie G, and Naeyaert JM.** Molecular motors and their role in pigmentation. *Cell Mol Biol* 45: 905–918, 1999.
 399. **Lammerding-Koppel M, Noda S, Blum A, Schaumburg-Lever G, Rassner G, and Drews U.** Immunohistochemical localization of muscarinic acetylcholine receptors in primary and metastatic malignant melanomas. *J Cutan Pathol* 24: 137–144, 1997.
 400. **Land EJ, Ramsden CA, and Riley PA.** Tyrosinase autoactivation and the chemistry of ortho-quinone amines. *Acc Chem Res* 36: 300–308, 2003.
 401. **Land EJ, Ramsden CA, Riley PA, and Yoganathan G.** Mechanistic studies of catechol generation from secondary quinone amines relevant to indole formation and tyrosinase activation. *Pigment Cell Res* 16: 397–406, 2003.
 402. **Lande S, Pawelek J, Lerner AB, and Emanuel JR.** Assay of melanotropic peptides in an in vitro mammalian system. *J Invest Dermatol* 77: 244–245, 1981.
 403. **Landstrom U and Lovtrup S.** Tyrosine and the synthesis of melanin in embryonic cells from *Ambystoma mexicanum*. *Roux's Arch Dev Biol* 185: 201–207, 1978.
 404. **Laporte S, Denault JB, D'Orleans-Juste P, and Leduc R.** Presence of furin mRNA in cultured bovine endothelial cells and possible involvement of furin in the processing of the endothelin precursor. *J Cardiovasc Pharmacol* 22 Suppl 8: S7–S10, 1993.
 405. **Lassalle MW, Igarashi S, Sasaki M, Wakamatsu K, Ito S, and Horikoshi T.** Effects of melanogenesis-inducing nitric oxide and histamine on the production of eumelanin and pheomelanin in cultured human melanocytes. *Pigment Cell Res* 16: 81–84, 2003.
 406. **Lassam N and Bickford S.** Loss of *c-kit* expression in cultured melanoma cells. *Oncogene* 7: 51–56, 1992.
 407. **Le Fur N, Kelsall SR, Silvers WK, and Mintz B.** Selective increase in specific alternative splice variants of tyrosinase in murine melanomas: a projected basis for immunotherapy. *Proc Natl Acad Sci USA* 94: 5332–5337, 1997.
 408. **Le Gros G, Zhang XM, and Parsons PG.** Alteration of tyrosinase activity in human melanocytes and melanoma cells by histamine H2 and H3 ligands. *Melanoma Res* 4: 359–364, 1994.
 409. **Lehmann B, Pietzsch J, Kampf A, and Meurer M.** Human keratinocyte line HaCaT metabolizes 1alpha-hydroxyvitamin D3 and vitamin D3 to 1alpha,25-dihydroxyvitamin D3 (calcitriol). *J Dermatol Sci* 18: 118–127, 1998.
 410. **LePoole C, Boissy R, Sarangarajan R, Chen J, Forristal J, Sheth P, Westerhof W, Babcock G, Das P, and Saelinger C.** PIG3V, an immortalized human vitiligo melanocyte cell line, expresses dilated endoplasmic reticulum. *In Vitro Cell Dev Biol Anim* 36: 309–319, 2000.
 411. **Le Poole IC, van den Wijngaard RM, Smit NP, Oosting J, Westerhof W, and Pavel S.** Catechol-O-methyltransferase in vitiligo. *Arch Dermatol Res* 286: 81–86, 1994.
 412. **Lerner AB.** The discovery of the melanotropins. A history of pituitary endocrinology. *Ann NY Acad Sci* 680: 1–12, 1993.
 413. **Lerner AB and Fitzpatrick TB.** Biochemistry of melanin formation. *Physiol Rev* 30: 1–126, 1950.
 414. **Lerner AB and McGuire J.** Effect of alpha- and beta-melanocyte stimulating hormones on the skin color of man. *Nature* 189: 176–179, 1961.
 415. **Lerner AB, Moellmann G, Varga VL, Halaban R, and Pawelek J.** Action of melanocyte-stimulating hormone on pigment cells. *Cold Spring Harbor Conf Cell Prolif* 6: 187–197, 1979.
 416. **Letterio JJ and Bottinger EP.** TGF-beta knockout and dominant-negative receptor transgenic mice. *Miner Electrolyte Metab* 24: 161–167, 1998.
 417. **Leurs R, Smit MJ, and Timmerman H.** Molecular pharmacological aspects of histamine receptors. *Pharmacol Ther* 66: 413–463, 1995.
 418. **Levine N, Lemus-Wilson A, Wood SH, Abdel Malek ZA, Al-Obeidi F, Hruby VJ, and Hadley ME.** Stimulation of follicular melanogenesis in the mouse by topical and injected melanotropins. *J Invest Dermatol* 89: 269–273, 1987.
 419. **Levine N, Sheftel SN, Eytan T, Dorr RT, Hadley ME, Weinrach JC, Ertl GA, Toth K, McGee DL, and Hruby VJ.** Induction of skin tanning by subcutaneous administration of a potent synthetic melanotropin. *JAMA* 266: 2730–2736, 1991.
 420. **Levins PC, Carr DB, Fisher JE, Momtaz K, and Parrish JA.** Plasma beta-endorphin and beta-lipoprotein response to ultraviolet radiation. *Lancet* 2: 166, 1983.
 421. **Lezcano NE, Salvatierra NA, and Celis ME.** Alpha-melanotropin hormone inhibits the binding of [³H]SCH 23390 to the dopamine D1 receptor in vitro. *Eur J Pharmacol* 363: 211–215, 1998.
 422. **Li X, Commane M, Jiang Z, and Stark GR.** IL-1-induced NFkappa B and c-Jun N-terminal kinase (JNK) activation diverge at IL-1 receptor-associated kinase (IRAK). *Proc Natl Acad Sci USA* 98: 4461–4465, 2001.
 423. **Lin CB, Babiarz L, Liebel F, Roydon Price E, Kizoulis M, Gendimenico GJ, Fisher DE, and Seiberg M.** Modulation of microphthalmia-associated transcription factor gene expression alters skin pigmentation. *J Invest Dermatol* 119: 1330–1340, 2002.
 424. **Lin ZQ, Kondo T, Ishida Y, Takayasu T, and Mukaida N.** Essential involvement of IL-6 in the skin wound-healing process as evidenced by delayed wound healing in IL-6-deficient mice. *J Leukoc Biol* 73: 713–721, 2003.
 425. **Lindblom J, Opmane B, Mutulis F, Mutule I, Petrovska R, Klusa V, Bergstrom L, and Wikberg JE.** The MC4 receptor mediates alpha-MSH induced release of nucleus accumbens dopamine. *Neuroreport* 12: 2155–2158, 2001.
 426. **Lindner G, Botchkarev VA, Botchkareva NV, Ling G, van der Veen C, and Paus R.** Analysis of apoptosis during hair follicle regression (catagen). *Am J Pathol* 151: 1601–1617, 1997.
 427. **Lindquist NG.** Accumulation of drugs on melanin. *Acta Radiol Diagn (Stockh)* 325: 1–92, 1973.
 428. **Lindquist NG, Larsson BS, and Lyden-Sokolowski A.** Neuronmelanin and its possible protective and destructive properties. *Pigment Cell Res* 1: 133–136, 1987.
 429. **Linnekin D.** Early signaling pathways activated by c-Kit in hematopoietic cells. *Int J Biochem Cell Biol* 31: 1053–1074, 1999.
 430. **Liu C, Ma X, Jiang X, Wilson SJ, Hofstra CL, Blevitt J, Pyati J, Li X, Chai W, Carruthers N, and Lovenberg TW.** Cloning and pharmacological characterization of a fourth histamine receptor [H(4)] expressed in bone marrow. *Mol Pharmacol* 59: 420–426, 2001.
 431. **Logan A and Weatherhead B.** Pelage color cycles and hair follicle tyrosinase activity in the Siberian hamster. *J Invest Dermatol* 71: 295–298, 1978.
 432. **Logan A and Weatherhead B.** Post-tyrosinase inhibition of melanogenesis by melatonin in hair follicles in vitro. *J Invest Dermatol* 74: 47–50, 1980.
 433. **Logan A and Weatherhead B.** Effects of alpha-melanocyte-stimulating hormone and [8-arginine] vasotocin upon melanogenesis in vitro. *J Endocrinol* 91: 501–507, 1981.
 434. **Lohmar P and Li CH.** Biological properties of ovine beta-lipotrophic hormone. *Endocrinology* 82: 898–904, 1968.
 435. **Longley BJ Jr, Morganroth GS, Tyrrell L, Ding TG, Anderson DM, Williams DE, and Halaban R.** Altered metabolism of mast-cell growth factor (*c-kit* ligand) in cutaneous mastocytosis. *N Engl J Med* 328: 1302–1307, 1993.
 436. **Lotan R and Lotan D.** Stimulation of melanogenesis in a human melanoma cell line by retinoids. *Cancer Res* 40: 3345–3350, 1980.
 437. **Lovenberg TW, Roland BL, Wilson SJ, Jiang X, Pyati J, Huvar A, Jackson MR, and Erlander MG.** Cloning and functional expression of the human histamine H3 receptor. *Mol Pharmacol* 55: 1101–1107, 1999.
 438. **Lovtrup Rehnholm A and Perris R.** Induction of the synthesis of melanin and pteridine in cells isolated from the otolotl embryo. *Dev Growth Differ* 26: 445–450, 1984.
 439. **Lu D, Willard D, Patel IR, Kadwell S, Overton L, Kost T, Luther M, Chen W, Woychik RP, Wilkison WO, and Cone RD.** Agouti protein is an antagonist of the melanocyte-stimulating-hormone receptor. *Nature* 371: 799–802, 1994.

440. Lu Y, Zhu WY, Tan C, Yu GH, and Gu JX. Melanocytes are potential immunocompetent cells: evidence from recognition of immunological characteristics of cultured human melanocytes. *Pigment Cell Res* 15: 454–460, 2002.
441. Ludwig DS, Mountjoy KG, Tatro JB, Gillette JA, Frederick RC, Flier JS, and Maratos-Flier E. Melanin-concentrating hormone: a functional melanocortin antagonist in the hypothalamus. *Am J Physiol Endocrinol Metab* 274: E627–E633, 1998.
442. Luger T, Paus R, Slominski A, and Lipton J. Cutaneous neuromodulation: the proopiomelanocortin system. *Ann NY Acad Sci* 885: 1–479, 1999.
443. Lukiewicz S. Interference with Endogenous Radioprotectors as a Method of Radiosensitization in IAEA's Modification of Radiosensitivity of Biological Systems. *Proc Advisory Group Meeting. Proc Advisory Group Meeting Intern Atomic Energy Agency Vienna Switzerland* 1976, p. 61–76.
444. Luo D, Chen H, Searles G, and Jimbow K. Coordinated mRNA expression of c-Kit with tyrosinase and TRP-1 in melanin pigmentation of normal and malignant human melanocytes and transient activation of tyrosinase by Kit/SCF-R. *Melanoma Res* 5: 303–309, 1995.
445. Lupetti R, Pisarra P, Verrecchia A, Farina C, Nicolini G, Anichini A, Bordignon C, Sensi M, Parmiani G, and Traversari C. Translation of a retained intron in tyrosinase-related protein (TRP) 2 mRNA generates a new cytotoxic T lymphocyte (CTL)-defined and shared human melanoma antigen not expressed in normal cells of the melanocytic lineage. *J Exp Med* 188: 1005–1016, 1998.
446. Mac Neil S, Johnson SK, Bleehen SS, Brown BL, and Tomlinson S. Stimulation of the adenylate cyclase of A B16 melanoma cell line by pro-opiomelanocortin-related peptides—a structure-activity study. *Regul Pept* 2: 193–200, 1981.
447. Maeda K and Naganuma M. Melanocyte-stimulating properties of secretory phospholipase A₂. *Photochem Photobiol* 65: 145–149, 1997.
448. Maeda K, Naganuma M, Fukuda M, Matsunaga J, and Tomita Y. Effect of pituitary and ovarian hormones on human melanocytes in vitro. *Pigment Cell Res* 9: 204–212, 1996.
449. Maeda K, Tomita Y, Naganuma M, and Tagami H. Phospholipases induce melanogenesis in organ-cultured skin. *Photochem Photobiol* 64: 220–223, 1996.
450. Malaviya R, Morrison AR, and Pentland AP. Histamine in human epidermal cells is induced by ultraviolet light injury. *J Invest Dermatol* 106: 785–789, 1996.
451. Manga P, Boissy RE, Pifko-Hirst S, Zhou BK, and Orlow SJ. Mislocalization of melanosomal proteins in melanocytes from mice with oculocutaneous albinism type 2. *Exp Eye Res* 72: 695–710, 2001.
452. Manga P, Sato K, Ye L, Beermann F, Lamoreux ML, and Orlow SJ. Mutational analysis of the modulation of tyrosinase by tyrosinase-related proteins 1 and 2 in vitro. *Pigment Cell Res* 13: 364–374, 2000.
453. Mangelsdorf DJ, Thummel C, Beato M, Herrlich P, Schutz G, Umesono K, Blumberg B, Kastner P, Mark M, and Chambon P. The nuclear receptor superfamily: the second decade. *Cell* 83: 835–839, 1995.
454. Mani I, Sharma V, Tamboli I, and Raman G. Interaction of melanin with proteins—the importance of an acidic intramelanosomal pH. *Pigment Cell Res* 14: 170–179, 2001.
455. Mansur CP, Gordon PR, Ray S, Holick MF, and Gilchrist BA. Vitamin D, its precursors, and metabolites do not affect melanization of cultured human melanocytes. *J Invest Dermatol* 91: 16–21, 1988.
456. Marks M and Seabra M. The melanosome: membrane dynamics in black and white. *Nat Rev Mol Cell Biol* 2: 1–11, 2001.
457. Marles LK, Peters EM, Tobin DJ, Hibberts NA, and Schallerreuter KU. Tyrosine hydroxylase isoenzyme I is present in human melanosomes: a possible novel function in pigmentation. *Exp Dermatol* 12: 61–70, 2003.
458. Mars U and Larsson BS. Pheomelanin as a binding site for drugs and chemicals. *Pigment Cell Res* 12: 266–274, 1999.
459. Martinez EA, Vassell D, and Stefano GB. Opioid potentiated chromatophorotropin regulation of pigment migration in the land crab *Gecarcinus lateralis*. *Comp Biochem Physiol C Pharmacol* 83: 77–82, 1986.
460. Martinez-Esparza M, Ferrer C, Castells MT, Garcia-Borrón JC, and Zuasti A. Transforming growth factor beta1 mediates hypopigmentation of B16 mouse melanoma cells by inhibition of melanin formation and melanosome maturation. *Int J Biochem Cell Biol* 33: 971–983, 2001.
461. Martinez-Esparza M, Jimenez-Cervantes C, Solano F, Lozano JA, and Garcia-Borrón JC. Mechanisms of melanogenesis inhibition by tumor necrosis factor-alpha in B16/F10 mouse melanoma cells. *Eur J Biochem* 255: 139–146, 1998.
462. Martinez-Esparza M, Jimenez-Cervantes C, Solano F, Lozano JA, and Garcia-Borrón JC. Regulation of the murine silver locus product (gp87) by the hypopigmenting cytokines TGF-beta1 and TNF-alpha. *Pigment Cell Res* 13: 120–126, 2000.
463. Martinez-Esparza M, Solano F, and Garcia-Borrón JC. Independent regulation of tyrosinase by the hypopigmenting cytokines TGF beta1 and TNF alpha and the melanogenic hormone alpha-MSH in B16 mouse melanocytes. *Cell Mol Biol* 45: 991–1000, 1999.
464. Mason HS. The chemistry of melanin. III. Mechanism of the oxidation of dihydroxyphenylalanine by tyrosinase. *J Biol Chem* 172: 83–98, 1948.
465. Masson P. Pigment cells in man. In: *Biology of Melanosomes*, edited by Miner RW and Gordon M. New York: NY Acad Sci, 1948, p. 15–24.
466. Matsumoto K, Hashimoto K, Nishida Y, Hashiro M, and Yoshikawa K. Growth-inhibitory effects of 1,25-dihydroxyvitamin D₃ on normal human keratinocytes cultured in serum-free medium. *Biochem Biophys Res Commun* 166: 916–923, 1990.
467. Matsunaga J, Sinha D, Solano F, Santis C, Wistow G, and Hearing V. Macrophage migration inhibitory factor (MIF)—its role in catecholamine metabolism. *Cell Mol Biol* 45: 1035–1040, 1999.
468. Matsuoka LY, Wortsman J, Haddad JG, Kolm P, and Hollis BW. Racial pigmentation and the cutaneous synthesis of vitamin D. *Arch Dermatol* 127: 536–538, 1991.
469. Mayfield DK, Brown AM, Page GP, Garvey WT, Shriver MD, and Argyropoulos G. A role for the agouti-related protein promoter in obesity and type 2 diabetes. *Biochem Biophys Res Commun* 287: 568–573, 2001.
470. Mazurkiewicz JE, Corliss D, and Slominski A. Spatiotemporal expression, distribution, and processing of POMC and POMC-derived peptides in murine skin. *J Histochem Cytochem* 48: 905–914, 2000.
471. McElhinney DB, Hoffman SJ, Robinson WA, and Ferguson J. Effect of melatonin on human skin color. *J Invest Dermatol* 102: 258–259, 1994.
472. McEwan M and Parsons PG. Inhibition of melanization in human melanoma cells by a serotonin uptake inhibitor. *J Invest Dermatol* 89: 82–86, 1987.
473. McEwan MT and Parsons PG. Regulation of tyrosinase expression and activity in human melanoma cells via histamine receptors. *J Invest Dermatol* 97: 868–873, 1991.
474. McGill GG, Horstmann M, Widlund HR, Du J, Motyckova G, Nishimura EK, Lin YL, Ramaswamy S, Avery W, Ding HF, Jordan SA, Jackson IJ, Korsmeyer SJ, Golub TR, and Fisher DE. Bcl2 regulation by the melanocyte master regulator Mitf modulates lineage survival and melanoma cell viability. *Cell* 109: 707–718, 2002.
475. McLane J, Osber M, and Pawelek JM. Phosphorylated isomers of L-dopa stimulate MSH binding capacity and responsiveness to MSH in cultured melanoma cells. *Biochem Biophys Res Commun* 145: 719–725, 1987.
476. McLane JA and Pawelek JM. Receptors for B-melanocyte-stimulating hormone exhibit positive cooperativity in synchronized melanoma cells. *Biochemistry* 27: 3743–3747, 1988.
477. Medrano EE, Farooqui JZ, Boissy RE, Boissy YL, Akadiri B, and Nordlund JJ. Chronic growth stimulation of human adult melanocytes by inflammatory mediators in vitro: implications for nevus formation and initial steps in melanocyte oncogenesis. *Proc Natl Acad Sci USA* 90: 1790–1794, 1993.
478. Melani C, Silvani A, Parmiani G, and Colombo MP. Lymphotoxin gene expression by melanocytes and melanoma cell lines and persistence of unspliced mRNA. *FEBS Lett* 335: 114–118, 1993.

479. **Menon C, Iyer M, Prabakaran I, Canter RJ, Lehr SC, and Fraker DL.** TNF-alpha downregulates vascular endothelial Flk-1 expression in human melanoma xenograft model. *Am J Physiol Heart Circ Physiol* 284: H317-H329, 2003.
480. **Michaud EJ, Bultman SJ, Stubbs LJ, and Woychik RP.** The embryonic lethality of homozygous lethal yellow mice (*Ay/Ay*) is associated with the disruption of a novel RNA-binding protein. *Genes Dev* 7: 1203-1213, 1993.
481. **Milde P, Hauser U, Simon T, Mall G, Ernst V, Haussler MR, Frosch P, and Rauterberg EW.** Expression of 1,25-dihydroxyvitamin D₃ receptors in normal and psoriatic skin. *J Invest Dermatol* 97: 230-239, 1991.
482. **Millar SE, Miller MW, Stevens ME, and Barsh GS.** Expression and transgenic studies of the mouse agouti gene provide insight into the mechanisms by which mammalian coat color patterns are generated. *Development* 121: 3223-3232, 1995.
483. **Miller MW, Duhl DM, Vrieling H, Cordes SP, Ollmann MM, Winkes BM, and Barsh GS.** Cloning of the mouse agouti gene predicts a secreted protein ubiquitously expressed in mice carrying the lethal yellow mutation. *Genes Dev* 7: 454-467, 1993.
484. **Millet L, Barbe P, Lafontan M, Berlan M, and Galitzky J.** Catecholamine effects on lipolysis and blood flow in human abdominal and femoral adipose tissue. *J Appl Physiol* 85: 181-188, 1998.
485. **Miranda M and Botti D.** Harding-passey mouse-melanoma tyrosinase inactivation by reaction products and activation by L-epinephrine. *Gen Pharmacol* 14: 231-237, 1983.
486. **Mockus SM and Vrana KE.** Advances in the molecular characterization of tryptophan hydroxylase. *J Mol Neurosci* 10: 163-179, 1998.
487. **Moellmann G, Slominski A, Kuklinska E, and Lerner AB.** Regulation of melanogenesis in melanocytes. *Pigment Cell Res Suppl* 1: 79-87, 1988.
488. **Montagna W and Machida H.** The skin of primates. XXXII. The Philippine tarsier (*Tarsius syrichta*). *Am J Phys Anthropol* 25: 71-83, 1966.
489. **Montoliu L, Umland T, and Schutz G.** A locus control region at -12 kb of the tyrosinase gene. *EMBO J* 15: 6026-6034, 1996.
490. **Moore J, Wood JM, and Schallreuter KU.** Evidence for specific complex formation between alpha-melanocyte stimulating hormone and 6(R)-L-erythro-5,6,7,8-tetrahydrobiopterin using near infrared Fourier transform Raman spectroscopy. *Biochemistry* 38: 15317-15324, 1999.
491. **Morelli JG, Kincannon J, Yohn JJ, Zekman T, Weston WL, and Norris DA.** Leukotriene C₄ and TGF-alpha are stimulators of human melanocyte migration in vitro. *J Invest Dermatol* 98: 290-295, 1992.
492. **Morelli JG, Yohn JJ, Lyons MB, Murphy RC, and Norris DA.** Leukotrienes C₄ and D₄ as potent mitogens for cultured human neonatal melanocytes. *J Invest Dermatol* 93: 719-722, 1989.
493. **Mori M, Harada M, Terao Y, Sugo T, Watanabe T, Shimomura Y, Abe M, Shintani Y, Onda H, Nishimura O, and Fujino M.** Cloning of a novel G protein-coupled receptor, SLT, a subtype of the melanin-concentrating hormone receptor. *Biochem Biophys Res Commun* 283: 1013-1018, 2001.
494. **Moriarty CM, Stucky JL, Hamburger KW, Patil KD, Foley JF, and Koefoot RR.** Blood histamine and solid malignant tumors. *J Cancer Res Clin Oncol* 114: 588-592, 1988.
495. **Morrone A, Picardo M, de Luca C, Terminali O, Passi S, and Ippolito F.** Catecholamines and vitiligo. *Pigment Cell Res* 5: 65-69, 1992.
496. **Motro B, van der Kooy D, Rossant J, Reith A, and Bernstein A.** Contiguous patterns of *c-kit* and *steel* expression: analysis of mutations at the W and Sl loci. *Development* 113: 1207-1221, 1991.
497. **Mountjoy KG, Mortrud MT, Low MJ, Simerly RB, and Cone RD.** Localization of the melanocortin-4 receptor (MC4-R) in neuroendocrine and autonomic control circuits in the brain. *Mol Endocrinol* 8: 1298-1308, 1994.
498. **Mountjoy KG, Robbins LS, Mortrud M, and Cone RD.** The cloning of a family genes that encode melanocortin receptors. *Science* 257: 1248-1251, 1992.
499. **Mozzanica N, Villa ML, Foppa S, Vignati G, Cattaneo A, Diotti R, and Finzi AF.** Plasma alpha-melanocyte-stimulating hormone, beta-endorphin, Met-enkephalin, and natural killer cell activity in vitiligo. *J Am Acad Dermatol* 26: 693-700, 1992.
500. **Muller G, Ruppert S, Schmid E, and Schutz G.** Functional analysis of alternatively spliced tyrosinase gene transcripts. *EMBO J* 7: 2723-2730, 1988.
501. **Murayama T, Kajiyama Y, and Nomura Y.** Histamine-stimulated and GTP-binding proteins-mediated phospholipase A₂ activation in rabbit platelets. *J Biol Chem* 265: 4290-4295, 1990.
502. **Muto M, Furumoto H, Ohmura A, and Asagami C.** Successful treatment of vitiligo with a sex steroid-thyroid hormone mixture. *J Dermatol* 22: 770-772, 1995.
503. **Nahon JL, Presse F, Bittencourt JC, Sawchenko PE, and Vale W.** The rat melanin-concentrating hormone messenger ribonucleic acid encodes multiple putative neuropeptides coexpressed in the dorsolateral hypothalamus. *Endocrinology* 125: 2056-2065, 1989.
504. **Naito M, Nakai Y, Kawauchi H, and Hayashi Y.** Immunocytochemical identification of melanin-concentrating hormone in the brain and pituitary gland of the teleost fishes *Oncorhynchus keta* and *Salmo gairdneri*. *Cell Tissue Res* 242: 41-48, 1985.
505. **Naoi M, Minami M, Maruyama W, and Parvez SH.** Allosteric regulation of tyrosine hydroxylase activity by its cofactor tetrahydrobiopterin. In: *Tyrosine Hydroxylase*, edited by Naoi M and Parvez SH. Utrecht, The Netherlands: VSP, 1993.
506. **Nash MS and Osborne NN.** Pertussis toxin-sensitive melatonin receptors negatively coupled to adenylate cyclase associated with cultured human and rat retinal pigment epithelial cells. *Invest Ophthalmol Vis Sci* 36: 95-102, 1995.
507. **Nguyen T, Shapiro DA, George SR, Setola V, Lee DK, Cheng R, Rausler L, Lee SP, Lynch KR, Roth BL, and O'Dowd BF.** Discovery of a novel member of the histamine receptor family. *Mol Pharmacol* 59: 427-433, 2001.
508. **Nguyen-Legros J, Versaux-Botteri C, and Vernier P.** Dopamine receptor localization in the mammalian retina. *Mol Neurobiol* 19: 181-204, 1999.
509. **Niles RM.** Vitamin A (retinoids) regulation of mouse melanoma growth and differentiation. *J Nutr* 133: 282S-286S, 2003.
510. **Nishikawa S, Kusakabe M, Yoshinaga K, Ogawa M, Hayashi S, Kunisada T, Era T, and Sakakura T.** In utero manipulation of coat color formation by a monoclonal anti-*c-kit* antibody: two distinct waves of *c-kit*-dependency during melanocyte development. *EMBO J* 10: 2111-2118, 1991.
511. **Nord EP.** Signalling pathways activated by endothelin stimulation of renal cells. *Clin Exp Pharmacol Physiol* 23: 331-336, 1996.
512. **Nordlund JJ.** The lives of pigment cells. *Clin Geriatr Med* 5: 91-108, 1989.
513. **Nordlund JJ and Abdel-Malek ZA.** Mechanisms for post-inflammatory hyperpigmentation and hypopigmentation. *Prog Clin Biol Res* 256: 219-236, 1988.
514. **Nordlund JJ, Amornsiripanitch S, Rheins LA, Abdel-Malek ZA, Boissy RE, and Bell M.** Role of the melanocyte in epidermal inflammatory and immune responses. *Pigment Cell Res Suppl* 1: 101-112, 1988.
515. **Nordlund JJ, Boissy RE, Hearing VJ, King RA, and Ortonne JP.** *The Pigmentary System. Physiology and Pathophysiology*. New York: Oxford Univ. Press, 1998.
516. **Nordlund JJ and Lerner AB.** The effects of oral melatonin on skin color and on the release of pituitary hormones. *J Clin Endocrinol Metab* 45: 768-774, 1977.
517. **Nordlund JJ and Ortonne JP.** The normal color of human skin. In: *The Pigmentary System: Physiology and Pathophysiology*, edited by Nordlund JJ and Boissy RE. New York: Oxford Univ. Press, 1998, p. 475-487.
518. **Norris A, Todd C, Graham A, Quinn AG, and Thody AJ.** The expression of the *c-kit* receptor by epidermal melanocytes may be reduced in vitiligo. *Br J Dermatol* 134: 299-306, 1996.
519. **Norris DA, Morelli JG, and Fujita M.** Melanocytes interactions in skin. In: *The Pigmentary System*, edited by Nordlund JJ, Boissy RE, Hearing VJ, King RA, and Ortonne J-P. New York: Oxford Univ. Press, 1998, p. 123-133.
520. **Obata H, Kaji Y, Yamada H, Kato M, Tsuru T, and Yamashita H.** Expression of transforming growth factor-beta superfamily receptors in rat eyes. *Acta Ophthalmol Scand* 77: 151-156, 1999.

521. Oda T, Morikawa N, Saito Y, Masuho Y, and Matsumoto S. Molecular cloning and characterization of a novel type of histamine receptor preferentially expressed in leukocytes. *J Biol Chem* 275: 36781–36786, 2000.
522. Odh G, Carstam R, Paulson J, Wittbjørn A, Rosengren E, and Rorsman H. Neuromelanin of the human substantia nigra: a mixed-type melanin. *J Neurochem* 62: 2030–2036, 1994.
523. Odh G, Hindemith A, Rosengren AM, Rosengren E, and Rorsman H. Isolation of a new tautomerase monitored by the conversion of D-dopachrome to 5,6-dihydroxyindole. *Biochem Biophys Res Commun* 197: 619–624, 1993.
524. Oetting WS and King RA. Molecular basis of albinism: mutations and polymorphisms of pigmentation genes associated with albinism. *Hum Mutat* 13: 99–115, 1999.
525. Ohtsu H and Watanabe T. New functions of histamine found in histidine decarboxylase gene knockout mice. *Biochem Biophys Res Commun* 305: 443–447, 2003.
526. Oikarinen A, Oikarinen H, Meeker CA, Tan EM, and Uitto J. Glucocorticoid receptors in cultured human skin fibroblasts: evidence for down-regulation of receptor by glucocorticoid hormone. *Acta Derm Venereol* 67: 461–468, 1987.
527. Oikawa A and Nakayasu M. Stimulation of melanogenesis in cultured melanoma cells by calciferols. *FEBS Lett* 42: 32–35, 1974.
528. Okano-Mitani H, Ikai K, and Imamura S. Human melanoma cells generate leukotrienes B₄ and C₄ from leukotriene A₄. *Arch Dermatol Res* 289: 347–351, 1997.
529. Okazaki K, Uzuka M, Morikawa F, Toda K, and Seiji M. Transfer mechanism of melanosomes in epidermal cell culture. *J Invest Dermatol* 67: 541–547, 1976.
530. Okun MR. The role of peroxidase in mammalian melanogenesis: a review. *Physiol Chem Phys Med NMR* 28: 91–101, 1996.
531. Okun MR. The role of peroxidase in neuromelanin synthesis: a review. *Physiol Chem Phys Med NMR* 29: 15–22, 1997.
532. Okun MR and Bhawan J. Combined melanocytoma-mastocytoma in a case of nodular mastocytosis. *J Am Acad Dermatol* 1: 338–347, 1979.
533. Ollmann MM, Wilson BD, Yang YK, Kerns JA, Chen Y, Gantz I, and Barsh GS. Antagonism of central melanocortin receptors in vitro and in vivo by agouti-related protein. *Science* 278: 135–138, 1997.
534. Ono H, Kawa Y, Asano M, Ito M, Takano A, Kubota Y, Matsumoto J, and Mizoguchi M. Development of melanocyte progenitors in murine Steel mutant neural crest explants cultured with stem cell factor, endothelin-3, or TPA. *Pigment Cell Res* 11: 291–298, 1998.
535. Onozaki K, Matsushima K, Aggarwal BB, and Oppenheim JJ. Human interleukin 1 is a cytosolic factor for several tumor cell lines. *J Immunol* 135: 3962–3968, 1985.
536. Opdecamp K, Kos L, Arnheiter H, and Pavan WJ. Endothelin signalling in the development of neural crest-derived melanocytes. *Biochem Cell Biol* 76: 1093–1099, 1998.
537. Orlow SJ. Melanosomes are specialized members of the lysosomal lineage of organelles. *J Invest Dermatol* 105: 3–7, 1995.
538. Orlow SJ, Boissy RE, Moran DJ, and Pifko-Hirst S. Subcellular distribution of tyrosinase and tyrosinase-related protein-1: implications for melanosomal biogenesis. *J Invest Dermatol* 100: 55–64, 1993.
539. Orlow SJ and Brilliant MH. The pink-eyed dilution locus controls the biogenesis of melanosomes and levels of melanosomal proteins in the eye. *Exp Eye Res* 68: 147–154, 1999.
540. Orlow SJ, Chakraborty AK, Boissy RE, and Pawelek JM. Inhibition of induced melanogenesis in Cloudman melanoma cells by four phenotypic modifiers. *Exp Cell Res* 191: 209–218, 1990.
541. Orlow SJ, Chakraborty AK, and Pawelek JM. Retinoic acid is a potent inhibitor of inducible pigmentation in murine and hamster melanoma cell lines. *J Invest Dermatol* 94: 461–464, 1990.
542. Orlow SJ, Zhou BK, Chakraborty AK, Drucker M, Pifko-Hirst S, and Pawelek JM. High-molecular-weight forms of tyrosinase and the tyrosinase-related proteins: evidence for a melanogenic complex. *J Invest Dermatol* 103: 196–201, 1994.
543. Ortonne JP. Retinoic acid and pigment cells: a review of in-vitro and in-vivo studies. *Br J Dermatol* 127 Suppl 41: 43–47, 1992.
544. Osak W, Tkacz K, Czternastek H, and Slawinski J. Characteristics and electrical conductivity of synthetic melanin. *Biopolymers* 28: 1885–1890, 1989.
545. Osborne NN, FitzGibbon F, and Schwartz G. Muscarinic acetylcholine receptor-mediated phosphoinositide turnover in cultured human retinal pigment epithelium cells. *Vision Res* 31: 1119–1127, 1991.
546. O'Sullivan JR, Williams A, Gummer C, and Tobin DJ. Distribution of follicular melanocytes during the hair growth cycle. *Invest Dermatol* 114: 861, 2000.
547. Oyeaug L, Plathe E, Vage DI, and Omholt SW. The regulatory basis of melanogenic switching. *J Theor Biol* 215: 449–468, 2002.
548. Ozeki H, Ito S, Wakamatsu K, and Hirobe T. Chemical characterization of hair melanins in various coat-color mutants of mice. *J Invest Dermatol* 105: 361–366, 1995.
549. Pagel M and Bodmer W. A naked ape would have fewer parasites. *Proc R Soc Lond B Biol Sci* 270 Suppl 1: S117–S119, 2003.
550. Pandolf KB, Gange RW, Latzka WA, Blank IH, Kraning KK, 2nd, and Gonzalez RR. Human thermoregulatory responses during heat exposure after artificially induced sunburn. *Am J Physiol Regul Integr Comp Physiol* 262: R610–R616, 1992.
551. Park HY and Gilchrist BA. The involvement of the protein kinase C pathway in melanogenesis. In: *Mechanisms of Suntanning*, edited by Ortonne JP and Ballotti R. London: Martin Dunitz, 2002, p. 179–186.
552. Park HY and Gilchrist BA. Signaling pathways mediating melanogenesis. *Cell Mol Biol* 45: 919–930, 1999.
553. Park HY, Perez JM, Laursen R, Hara M, and Gilchrist BA. Protein kinase C-beta activates tyrosinase by phosphorylating serine residues in its cytoplasmic domain. *J Biol Chem* 274: 16470–16478, 1999.
554. Park HY, Russakovsky V, Ao Y, Fernandez E, and Gilchrist BA. Alpha-melanocyte stimulating hormone-induced pigmentation is blocked by depletion of protein kinase C. *Exp Cell Res* 227: 70–79, 1996.
555. Park HY, Russakovsky V, Ohno S, and Gilchrist BA. The beta isoform of protein kinase C stimulates human melanogenesis by activating tyrosinase in pigment cells. *J Biol Chem* 268: 11742–11749, 1993.
556. Parsad D, Pandhi R, Dogra S, and Kumar B. Topical prostaglandin analog (PGE₂) in vitiligo—a preliminary study. *Int J Dermatol* 41: 942–945, 2002.
557. Pasternak GW. Pharmacological mechanisms of opioid analgesics. *Clin Neuropharmacol* 16: 1–18, 1993.
558. Paus R, Slominski A, and Czarnecki B. Is alopecia areata an autoimmune-response against melanogenesis-related proteins, exposed by abnormal MHC class I expression in the anagen hair bulb? *Yale J Biol Med* 66: 541–554, 1995.
559. Pawelek J. Studies on the Cloudman melanoma cell line as a model for the action of MSH. *Yale J Biol Med* 58: 571–578, 1985.
560. Pawelek J, Bologna J, McLane J, Murray M, Osber M, and Slominski A. A possible role for melanin precursors in regulating both pigmentation and proliferation of melanocytes. *Prog Clin Biol Res* 256: 143–154, 1988.
561. Pawelek J, Chakraborty A, Osber MP, Orlow SJ, Min KK, Rosenzweig KE, and Bologna JL. Molecular cascades in UV-induced melanogenesis: a central role for melanotropins? *Pigment Cell Res* 5: 34–356, 1992.
562. Pawelek J, Fleischman RA, McLane J, Guillette B, Emanuel JR, and Korner A. Studies on growth and pigmentation of Cloudman S91 melanoma cells. *Pigment Cell Res* 6: 521–533, 1984.
563. Pawelek J, Fleischman RA, McLane J, Guillette B, Emanuel JR, Korner A, Bergstrom A, and Murray M. Studies on growth and pigmentation of cloudman S91 melanoma cells. In: *Biological, Molecular and Clinical Aspects of Pigmentation*, edited by Bagrara JT, Klaus SN, Paul E, and Scharl M. Tokyo: Univ. of Tokyo Press, 1985, p. 521–533.
564. Pawelek J, Halaban R, and Christie G. Melanoma cells which require cyclic AMP for growth. *Nature* 258: 539–540, 1975.
565. Pawelek J, Korner A, Bergstrom A, and Bologna J. New regulators of melanin biosynthesis and the autodestruction of melanoma cells. *Nature* 286: 617–619, 1980.

566. **Pawelek J, Sansone M, Koch N, Christie G, Halaban R, Hendee J, Lerner AB, and Varga JM.** Melanoma cells resistant to inhibition of growth by melanocyte stimulating hormone. *Proc Natl Acad Sci USA* 72: 951–955, 1975.
567. **Pawelek J, Sansone M, Morowitz J, Moellmann G, and Godawska E.** Genetic control of melanization: isolation and analysis of amelanotic variants from cultured melanotic melanoma cells. *Proc Natl Acad Sci USA* 71: 1073–1077, 1974.
568. **Pawelek J, Wong G, Sansone M, and Morowitz J.** Molecular biology of pigment cells. Molecular controls in mammalian pigmentation. *Yale J Biol Med* 46: 430–443, 1973.
569. **Pawelek JM.** Factors regulating growth and pigmentation of melanoma cells. *J Invest Dermatol* 66: 201–209, 1976.
570. **Pawelek JM.** Evidence suggesting that a cyclic AMP-dependent protein kinase is a positive regulator of proliferation in Cloudman S91 melanoma cells. *J Cell Physiol* 98: 619–625, 1979.
571. **Pawelek JM.** Regulation of pigmentation and proliferation in cultured melanocytes. In: *Methods for Serum-Free Culture of Neuronal and Lymphoid Cells*. New York: Liss, 1984, p. 57–66.
572. **Pawelek JM.** Is human melanogenesis stimulated by cyclic AMP? *J Invest Dermatol* 94: 499–500, 1990.
573. **Pawelek JM.** After dopachrome? *Pigment Cell Res* 4: 53–62, 1991.
574. **Pawelek JM.** Proopiomelanocortin in skin: new possibilities for regulation of skin physiology. *J Lab Clin Med* 122: 627–628, 1993.
575. **Pawelek JM and Korner AM.** The biosynthesis of mammalian melanin. *Am Sci* 70: 136–145, 1982.
576. **Pears JS, Jung RT, Bartlett W, Browning MC, Kenicer K, and Thody AJ.** A case of skin hyperpigmentation due to alpha-MSH hypersecretion. *Br J Dermatol* 126: 286–289, 1992.
577. **Perris R.** The extracellular matrix in neural crest-cell migration. *Trends Neurosci* 20: 23–31, 1997.
578. **Peters EM, Tobin DJ, Botchkareva N, Maurer M, and Paus R.** Migration of melanoblasts into the developing murine hair follicle is accompanied by transient c-Kit expression. *J Histochem Cytochem* 50: 751–766, 2002.
579. **Peters EM, Tobin DJ, Seidah NG, and Schallreuter KU.** Proopiomelanocortin-related peptides, prohormone convertases 1 and 2 and the regulatory peptide 7B2 are present in melanosomes of human melanocytes. *J Invest Dermatol* 114: 430–437, 2000.
580. **Peterziel H, Mink S, Schonert A, Becker M, Klocker H, and Cato AC.** Rapid signalling by androgen receptor in prostate cancer cells. *Oncogene* 18: 6322–6329, 1999.
581. **Petris MJ, Strausak D, and Mercer JF.** The Menkes copper transporter is required for the activation of tyrosinase. *Hum Mol Genet* 9: 2845–2851, 2000.
582. **Phan LK, Lin F, LeDuc CA, Chung WK, and Leibel RL.** The mouse mahoganoid coat color mutation disrupts a novel C3HC4 RING domain protein. *J Clin Invest* 110: 1449–1459, 2002.
583. **Phillips J, Gawkrödger DJ, Caddy CM, Hedley S, Dawson RA, Smith-Thomas L, Freedlander E, and MacNeil S.** Keratinocytes suppress TRP-1 expression and reduce cell number of co-cultured melanocytes: implications for grafting of patients with vitiligo. *Pigment Cell Res* 14: 116–125, 2001.
584. **Pingault V, Bondurand N, Kuhlbrodt K, Goerich DE, Prehu MO, Puliti A, Herbarth B, Hermans-Borgmeyer I, Legius E, Matthijs G, Amiel J, Lyonnet S, Ceccherini I, Romeo G, Smith JC, Read AP, Wegner M, and Goossens M.** SOX10 mutations in patients with Waardenburg-Hirschsprung disease. *Nat Genet* 18: 171–173, 1998.
585. **Pisarra P, Lupetti R, Palumbo A, Napolitano A, Protta G, Parmiani G, Anichini A, and Sensi M.** Human melanocytes and melanomas express novel mRNA isoforms of the tyrosinase-related protein-2/DOPachrome tautomerase gene: molecular and functional characterization. *J Invest Dermatol* 115: 48–56, 2000.
586. **Plonka PM, Slominski AT, Pajak S, and Urbanska K.** Transplantable melanomas in gerbils (*Meriones unguiculatus*). II: melanogenesis. *Exp Dermatol* 12: 356–364, 2003.
587. **Pomerantz SH.** The tyrosine hydroxylase activity of mammalian tyrosinase. *J Biol Chem* 241: 161–168, 1966.
588. **Pomerantz SH and Chuang L.** Effects of beta-MSH, cortisol and ACTH on tyrosinase in the skin of newborn hamsters and mice. *Endocrinology* 87: 302–310, 1970.
589. **Ponec M, Kempenaar JA, and De Kloet ER.** Corticoids and cultured human epidermal keratinocytes: specific intracellular binding and clinical efficacy. *J Invest Dermatol* 76: 211–214, 1981.
590. **Porter S and Mintz B.** Multiple alternatively spliced transcripts of the mouse tyrosinase-encoding gene. *Gene* 97: 277–282, 1991.
591. **Post PW, Daniels F Jr, and Binford RT Jr.** Cold injury and the evolution of “white” skin. *Hum Biol* 47: 65–80, 1975.
592. **Potterf SB and Hearing VJ.** Tyrosine transport into melanosomes is increased following stimulation of melanocyte differentiation. *Biochem Biophys Res Commun* 248: 795–800, 1998.
593. **Potterf SB, Muller J, Bernardini I, Tietze F, Kobayashi T, Hearing VJ, and Gahl WA.** Characterization of a melanosomal transport system in murine melanocytes mediating entry of the melanogenic substrate tyrosine. *J Biol Chem* 271: 4002–4008, 1996.
594. **Potterf SB, Virador V, Wakamatsu K, Furumura M, Santis C, Ito S, and Hearing VJ.** Cysteine transport in melanosomes from murine melanocytes. *Pigment Cell Res* 12: 4–12, 1999.
595. **Presse F, Nahon JL, Fischer WH, and Vale W.** Structure of the human melanin concentrating hormone mRNA. *Mol Endocrinol* 4: 632–637, 1990.
596. **Pringle JH, Fletcher A, Primrose L, and Hutchinson PE.** A quantitative reverse transcriptase polymerase chain reaction (RT-PCR): its use in measuring vitamin D receptor gene expression. In: *Vitamin D. Chemistry, Biology, and Clinical Applications of the Steroid Hormone*, edited by Norman AW, Bouillon R, and Thomas M. Riverside, CA: Univ. of California, 1997, p. 318–319.
597. **Protta G.** *Melanins and Melanogenesis*. New York: Academic, 1992.
598. **Protta G.** The chemistry of melanins and melanogenesis. *Fortsch Chem Organ Natur* 64: 93–148, 1995.
599. **Protta G, Vincenzi MR, Napolitano A, Selen G, and Stjernschantz J.** Latanoprost stimulates eumelanogenesis in iridial melanocytes of cynomolgus monkeys. *Pigment Cell Res* 13: 147–150, 2000.
600. **Puffenberger EG, Hosoda K, Washington SS, Nakao K, de Wit D, Yanagisawa M, and Chakravart A.** A missense mutation of the endothelin-B receptor gene in multigenic Hirschsprung’s disease. *Cell* 79: 1257–1266, 1994.
601. **Puri N, Gardner JM, and Brilliant MH.** Aberrant pH of melanosomes in pink-eyed dilution (p) mutant melanocytes. *J Invest Dermatol* 115: 607–613, 2000.
602. **Quevedo WC Jr.** Physiology of vertebrate dermal pigmentation. In: *Biology and Disease of Dermal Pigmentation*, edited by Fitzpatrick TB, Kukita A, Morikawa F, Seiji M, Sober A, and Toda K. Tokyo: Univ. of Tokyo Press, 1981, p. 39–50.
603. **Ramirez-Bosca A, Bernd A, Werner R, Dold K, and Holzmann H.** Effect of the dose of ultraviolet radiation on the pigment formation by human melanocytes in vitro. *Arch Dermatol Res* 284: 358–362, 1992.
604. **Rampen FH and Mulder JH.** Malignant melanoma: an androgen-dependent tumour? *Lancet* 1: 562–564, 1980.
605. **Ranadive NS, Shirwadkar S, Persad S, and Menon IA.** Effects of melanin-induced free radicals on the isolated rat peritoneal mast cells. *J Invest Dermatol* 86: 303–307, 1986.
606. **Ranson M, Posen S, and Mason RS.** Human melanocytes as a target tissue for hormones: in vitro studies with 1 alpha-25, dihydroxyvitamin D₃, alpha-melanocyte stimulating hormone, and beta-estradiol. *J Invest Dermatol* 91: 593–598, 1988.
607. **Raposo G, Fevrier B, Stoorvogel W, and Marks MS.** Lysosome-related organelles: a view from immunity and pigmentation. *Cell Struct Funct* 27: 443–456, 2002.
608. **Raposo G, Tenza D, Murphy DM, Berson JF, and Marks MS.** Distinct protein sorting and localization to premelanosomes, melanosomes, and lysosomes in pigmented melanocytic cells. *J Cell Biol* 152: 809–824, 2001.
609. **Rawles ME.** Origin of pigment cells from the neural crest in the mouse embryo. *Physiol Zool* 20: 248–266, 1947.
610. **Reichrath J, Muller SM, Kerber A, Baum HP, and Bahmer FA.** Biologic effects of topical calcipotriol (MC 903) treatment in psoriatic skin. *J Am Acad Dermatol* 36: 19–28, 1997.
611. **Reid K, Nishikawa S, Bartlett PF, and Murphy M.** Steel factor directs melanocyte development in vitro through selective regula-

- tion of the number of *c-kit*⁺ progenitors. *Dev Biol* 169: 568–579, 1995.
612. **Reid K, Turnley AM, Maxwell GD, Kurihara Y, Kurihara H, Bartlett PF, and Murphy M.** Multiple roles for endothelin in melanocyte development: regulation of progenitor number and stimulation of differentiation. *Development* 122: 3911–3919, 1996.
613. **Reppert SM, Godson C, Mahle CD, Weaver DR, Slangenaupt SA, and Gusella JF.** Molecular characterization of a second melatonin receptor expressed in human retina and brain: the Mel1b melatonin receptor. *Proc Natl Acad Sci USA* 92: 8734–8738, 1995.
614. **Reppert SM and Weaver DR.** Melatonin madness. *Cell* 83: 1059–1062, 1995.
615. **Reppert SM, Weaver DR, and Ebisawa T.** Cloning and characterization of a mammalian melatonin receptor that mediates reproductive and circadian responses. *Neuron* 13: 1177–1185, 1994.
616. **Reynolds JL, Akhter J, and Morris DL.** In vitro effect of histamine and histamine H1 and H2 receptor antagonists on cellular proliferation of human malignant melanoma cell lines. *Melanoma Res* 6: 95–99, 1996.
617. **Ribatti D, Ennas MG, Vacca A, Ferrelli F, Nico B, Orru S, and Sirigu P.** Tumor vascularity and tryptase-positive mast cells correlate with a poor prognosis in melanoma. *Eur J Clin Invest* 33: 420–425, 2003.
618. **Riley PA.** Melanin. *Int J Biochem Cell Biol* 29: 1235–1239, 1997.
619. **Riley PA.** Tyrosinase kinetics: a semi-quantitative model of the mechanism of oxidation of monohydric and dihydric phenolic substrates. *J Theor Biol* 203: 1–12, 2000.
620. **Rinchik EM, Bultman SJ, Horsthemke B, Lee ST, Strunk KM, Spritz RA, Avidano KM, Jong MT, and Nicholls RD.** A gene for the mouse pink-eyed dilution locus and for human type II oculocutaneous albinism. *Nature* 361: 72–76, 1993.
621. **Rios M, Habecker B, Sasaoka T, Eisenhofer G, Tian H, Landis S, Chikaraishi D, and Roffler-Tarlov S.** Catecholamine synthesis is mediated by tyrosinase in the absence of tyrosine hydroxylase. *J Neurosci* 19: 3519–3526, 1999.
622. **Ripple MO, Henry WF, Schwarze SR, Wilding G, and Weindruch R.** Effect of antioxidants on androgen-induced AP-1 and NF-kappaB DNA-binding activity in prostate carcinoma cells. *J Natl Cancer Inst* 91: 1227–1232, 1999.
623. **Ristic-Fira A, Vujcic M, Krstic-Demonacos M, and Kanazir D.** Identification and characterization of glucocorticoid receptors in B16 mouse melanoma cells. *Endocr Regul* 33: 109–115, 1999.
624. **Robbins LS, Nadeau JH, Johnson KR, Kelly MA, Roselli-Reh-fuss L, Baack E, Mountjoy KG, and Cone RD.** Pigmentation phenotypes of variant extension locus alleles result from point mutations that alter MSH receptor function. *Cell* 72: 827–834, 1993.
625. **Roberts JE, Wiechmann AF, and Hu DN.** Melatonin receptors in human uveal melanocytes and melanoma cells. *J Pineal Res* 28: 165–171, 2000.
626. **Robins AH.** *Biological Perspectives on Human Pigmentation.* Cambridge, UK: Cambridge Univ. Press, 1991.
627. **Romero C, Aberdam E, Larnier C, and Ortonne JP.** Retinoic acid as modulator of UVB-induced melanocyte differentiation. Involvement of the melanogenic enzymes expression. *J Cell Sci* 107: 1095–1103, 1994.
628. **Romero-Graillet C, Aberdam E, Biagoli N, Massabni W, Ortonne JP, and Ballotti R.** Ultraviolet B radiation acts through the nitric oxide and cGMP signal transduction pathway to stimulate melanogenesis in human melanocytes. *J Biol Chem* 271: 28052–28056, 1996.
629. **Ros JR, Rodriguez-Lopez JN, and Garcia-Canovas F.** Effect of L-ascorbic acid on the monophenolase activity of tyrosinase. *Biochem J* 295: 309–312, 1993.
630. **Rosati G, Granieri E, Pinna L, Aiello I, Tola R, De Bastiani P, Pirisi A, and Devoto MC.** The risk of Parkinson disease in Mediterranean people. *Neurology* 30: 250–255, 1980.
631. **Rosdahl I, Andersson E, Kagedal B, and Torma H.** Vitamin A metabolism and mRNA expression of retinoid-binding protein and receptor genes in human epidermal melanocytes and melanoma cells. *Melanoma Res* 7: 267–274, 1997.
632. **Rosdahl IK and Szabo G.** Mitotic activity of epidermal melanocytes in UV-irradiated mouse skin. *J Invest Dermatol* 70: 143–148, 1978.
633. **Rosei MA, Mosca L, Coccia R, Blarmino C, Musci G, and De Marco C.** Some biochemical properties of melanins from opioid peptides. *Biochim Biophys Acta* 1199: 123–129, 1994.
634. **Roselli-Reh-fuss L, Mountjoy KG, Robbins LS, Mortrud MT, Low MJ, Tatro JB, Entwistle ML, Simerly RB, and Cone RD.** Identification of a receptor for gamma melanotropin and other proopiomelanocortin peptides in the hypothalamus and limbic system. *Proc Natl Acad Sci USA* 90: 8856–8860, 1993.
635. **Rosemblat S, Sviderskaya EV, Easty DJ, Wilson A, Kwon BS, Bennett DC, and Orlow SJ.** Melanosomal defects in melanocytes from mice lacking expression of the pink-eyed dilution gene: correction by culture in the presence of excess tyrosine. *Exp Cell Res* 239: 344–352, 1998.
636. **Rosenbach T, Csato M, and Czarnetzki BM.** Studies on the role of leukotrienes in murine allergic and irritant contact dermatitis. *Br J Dermatol* 118: 1–6, 1988.
637. **Rosenbaum SE and Niles RM.** Regulation of protein kinase C gene expression by retinoic acid in B16 mouse melanoma cells. *Arch Biochem Biophys* 294: 123–129, 1992.
638. **Rosengren E, Bucala R, Aman P, Jacobsson L, Odh G, Metz CN, and Rorsman H.** The immunoregulatory mediator macrophage migration inhibitory factor (MIF) catalyzes a tautomerization reaction. *Mol Med* 2: 143–149, 1996.
639. **Rossi CR, Foletto M, Pilati P, Mocellin S, and Lise M.** Isolated limb perfusion in locally advanced cutaneous melanoma. *Semin Oncol* 29: 400–409, 2002.
640. **Rothman S.** Pathophysiology of the itch sensation. In: *Advances in Biology of Skin*, edited by Montagna W. New York: Pergamon, 1960, p. 189–200.
641. **Rubanyi GM and Polokoff MA.** Endothelins: molecular biology, biochemistry, pharmacology, physiology, and pathophysiology. *Pharmacol Rev* 46: 325–415, 1994.
642. **Ruppert S, Muller G, Kwon B, and Schutz G.** Multiple transcripts of the mouse tyrosinase gene are generated by alternative splicing. *EMBO J* 7: 2715–2722, 1988.
643. **Ruzicka T.** Leukotrienes in atopic eczema. *Acta Derm Venereol Suppl* 144: 48–49, 1989.
644. **Sahu SN, Edwards-Prasad J, and Prasad KN.** Alpha tocopheryl succinate inhibits melanocyte-stimulating hormone (MSH)-sensitive adenylate cyclase activity in melanoma cells. *J Cell Physiol* 133: 585–589, 1987.
645. **Sailer AW, Sano H, Zeng Z, McDonald TP, Pan J, Pong SS, Feighner SD, Tan CP, Fukami T, Iwaasa H, Hreniuk DL, Morin NR, Sadowski SJ, Ito M, Bansal A, Ky B, Figueroa DJ, Jiang Q, Austin CP, MacNeil DJ, Ishihara A, Ihara M, Kanatani A, Van der Ploeg LH, Howard AD, and Liu Q.** Identification and characterization of a second melanin-concentrating hormone receptor, MCH-2R. *Proc Natl Acad Sci USA* 98: 7564–7569, 2001.
646. **Sailer M, Oppitz M, and Drews U.** Induction of cellular contractions in the human melanoma cell line SK-mel 28 after muscarinic cholinergic stimulation. *Anat Embryol* 201: 27–37, 2000.
647. **Saito H, Yasumoto K, Takeda K, Takahashi K, Fukuzaki A, Orikasa S, and Shibahara S.** Melanocyte-specific microphthalmia-associated transcription factor isoform activates its own gene promoter through physical interaction with lymphoid-enhancing factor 1. *J Biol Chem* 277: 28787–28794, 2002.
648. **Saito H, Yasumoto K, Takeda K, Takahashi K, Yamamoto H, and Shibahara S.** Microphthalmia-associated transcription factor in the wnt signaling pathway. *Pigment Cell Res* 16: 261–265, 2003.
649. **Saito Y, Nothacker HP, Wang Z, Lin SH, Leslie F, and Civelli O.** Molecular characterization of the melanin-concentrating-hormone receptor. *Nature* 400: 265–269, 1999.
650. **Saito Y, Wang Z, Hagino-Yamagishi K, Civelli O, Kawashima S, and Maruyama K.** Endogenous melanin-concentrating hormone receptor SLC-1 in human melanoma SK-MEL-37 cells. *Biochem Biophys Res Commun* 289: 44–50, 2001.
651. **Sakai C, Kawakami Y, Law L, Furumura M, and Hearing VJ Jr.** Melanosomal proteins as melanoma-specific immune targets. *Melanoma Res* 7: 83–95, 1997.
652. **Sakai C, Ollmann M, Kobayashi T, Abdel-Malek Z, Muller J, Vieira WD, Imokawa G, Barsh GS, and Hearing VJ.** Modulation of murine melanocyte function in vitro by agouti signal protein. *EMBO J* 16: 3544–3552, 1997.

653. Sakurai T, Yanagisawa M, Takuwa Y, Miyazaki H, Kimura S, Goto K, and Masaki T. Cloning of a cDNA encoding a non-isopeptide-selective subtype of the endothelin receptor. *Nature* 348: 732–735, 1990.
654. Salopek TG and Jimbow K. Induction of melanogenesis during the various melanoma growth phases and the role of tyrosinase, lysosome-associated membrane proteins, and p90 calnexin in the melanogenesis cascade. *J Invest Dermatol Symp Proc* 1: 195–202, 1996.
655. Sanchez-Ferrer A, Rodriguez-Lopez JN, Garcia-Canovas F, and Garcia-Carmona F. Tyrosinase: a comprehensive review of its mechanism. *Biochim Biophys Acta* 1247: 1–11, 1995.
656. Sarangarajan R and Boissy RE. Tyrp1 and oculocutaneous albinism type 3. *Pigment Cell Res* 14: 437–444, 2001.
657. Sarangarajan R, Zhao Y, Babcock G, Cornelius J, Lamoreux ML, and Boissy RE. Mutant alleles at the brown locus encoding tyrosinase-related protein-1 (TRP-1) affect proliferation of mouse melanocytes in culture. *Pigment Cell Res* 13: 337–344, 2000.
658. Sarna T. Properties and function of the ocular melanin—a photo-physical view. *J Photochem Photobiol* 12: 215–258, 1992.
659. Satomi H, Wang B, Fujisawa H, and Otsuka F. Interferon-beta from melanoma cells suppresses the proliferations of melanoma cells in an autocrine manner. *Cytokine* 18: 108–115, 2002.
660. Schaffer JV and Bologna JL. The melanocortin-1 receptor: red hair and beyond. *Arch Dermatol* 137: 1477–1485, 2001.
661. Schallreuter K, Slominski A, Pawelek JM, Jimbow K, and Gilchrist BA. What controls melanogenesis? *Exp Dermatol* 7: 143–150, 1998.
662. Schallreuter KU, Korner C, Pittelkow MR, Swanson NN, and Gardner ML. The induction of the alpha-1-adrenoceptor signal transduction system on human melanocytes. *Exp Dermatol* 5: 20–23, 1996.
663. Schallreuter KU, Kothari S, Hasse S, Kauser S, Lindsey NJ, Gibbons NC, Hibberts N, and Wood JM. In situ and in vitro evidence for DCoH/HNF-1 alpha transcription of tyrosinase in human skin melanocytes. *Biochem Biophys Res Commun* 301: 610–616, 2003.
664. Schallreuter KU, Lemke KR, Hill HZ, and Wood JM. Thioredoxin reductase induction coincides with melanin biosynthesis in brown and black guinea pigs and in murine melanoma cells. *J Invest Dermatol* 103: 820–824, 1994.
665. Schallreuter KU, Lemke KR, Pittelkow MR, Wood JM, Korner C, and Malik R. Catecholamines in human keratinocyte differentiation. *J Invest Derm* 104: 953–957, 1995.
666. Schallreuter KU, Moore J, Tobin DJ, Gibbons NJ, Marshall HS, Jenner T, Beazley WD, and Wood JM. alpha-MSH can control the essential cofactor 6-tetrahydrobiopterin in melanogenesis. *Ann NY Acad Sci* 885: 329–341, 1999.
667. Schallreuter KU, Moore J, Wood JM, Beazley WD, Peters EM, Marles LK, Behrens-Williams SC, Dummer R, Blau N, and Thony B. Epidermal H(2)O(2) accumulation alters tetrahydrobiopterin (6BH4) recycling in vitiligo: identification of a general mechanism in regulation of all 6BH4-dependent processes? *J Invest Dermatol* 116: 167–174, 2001.
668. Schallreuter KU and Pittelkow MP. Defective calcium uptake in keratinocyte cell cultures from vitiliginous skin. *Arch Dermatol Res* 280: 137–139, 1988.
669. Schallreuter KU, Pittelkow MR, and Swanson NN. Defective calcium transport in vitiliginous melanocytes. *Arch Dermatol Res* 288: 11–13, 1996.
670. Schallreuter KU, Schulz-Douglas V, Bunz A, Beazley WD, and Korner C. Pteridines in the control of pigmentation. *J Invest Dermatol* 109: 31–35, 1997.
671. Schallreuter KU and Wood JM. Downregulation of tyrosinase activity in human melanocyte cell cultures by yohimbine. *J Invest Dermatol* 115: 130–131, 2000.
672. Schallreuter KU and Wood JM. Free radical reduction in the human epidermis. *Free Radical Biol Med* 6: 519–532, 1989.
673. Schallreuter KU and Wood JM. The importance of L-phenylalanine transport and its autocrine turnover to L-tyrosine for melanogenesis in human epidermal melanocytes. *Biochem Biophys Res Commun* 262: 423–428, 1999.
674. Schallreuter KU, Wood JM, Korner C, Harle KM, Schulz-Douglas V, and Werner ER. 6-Tetrahydrobiopterin functions as a UVB-light switch for de novo melanogenesis. *Biochim Biophys Acta* 1382: 339–344, 1998.
675. Schallreuter KU, Wood JM, Lemke R, LePoole C, Das P, Westerhof W, Pittelkow MR, and Thody AJ. Production of catecholamines in the human epidermis. *Biochem Biophys Res Commun* 189: 72–78, 1992.
676. Schallreuter KU, Wood JM, Pittelkow MR, Gutlich M, Lemke KR, Rodl W, Swanson NN, Hitzemann K, and Ziegler I. Regulation of melanin biosynthesis in the human epidermis by tetrahydrobiopterin. *Science* 263: 1444–1446, 1994.
677. Schallreuter KU, Wood JM, Ziegler I, Lemke KR, Pittelkow MR, Lindsey NJ, and Gutlich M. Defective tetrahydrobiopterin and catecholamine biosynthesis in the depigmentation disorder vitiligo. *Biochim Biophys Acta* 1226: 181–192, 1994.
678. Schauer E, Trautinger F, Kock A, Schwarz A, Bhardwaj R, Simon M, Ansel JC, Schwarz T, and Luger TA. Proopiomelanocortin-derived peptides are synthesized and released by human keratinocytes. *J Clin Invest* 93: 2258–2262, 1994.
679. Schorderet M and Nowak JZ. Retinal dopamine D1 and D2 receptors: characterization by binding or pharmacological studies and physiological functions. *Cell Mol Neurobiol* 10: 303–325, 1990.
680. Schuessler M, Astecker N, Herzig G, Vorisek G, and Schuster I. Skin is an autonomous organ in synthesis, two-step activation and degradation of vitamin D(3): CYP27 in epidermis completes the set of essential vitamin D(3)-hydroxylases. *Steroids* 66: 399–408, 2001.
681. Schwahn DJ, Xu W, Herrin AB, Bales ES, and Medrano EE. Tyrosine levels regulate the melanogenic response to alpha-melanocyte-stimulating hormone in human melanocytes: implications for pigmentation and proliferation. *Pigment Cell Res* 14: 32–39, 2001.
682. Scislawski PW and Slominski A. The role of NADP-dependent dehydrogenases in hydroxylation of tyrosine in hamster melanoma. *Neoplasma* 30: 239–243, 1983.
683. Scislawski PW, Slominski A, Bomirski A, and Zydowo M. Metabolic characterization of three hamster melanoma variants. *Neoplasma* 32: 593–598, 1985.
684. Scislawski PWD, Slominski A, and Bomirski A. Biochemical characterization of three hamster melanoma variants. II. Glycolysis and oxygen consumption. *Int J Biochem* 16: 327–331, 1984.
685. Scott G, Ewing J, Ryan D, and Abboud C. Stem cell factor regulates human melanocyte-matrix interactions. *Pigment Cell Res* 7: 44–51, 1994.
686. Scott G, Leopardi S, Printup S, and Madden BC. Filopodia are conduits for melanosome transfer to keratinocytes. *J Cell Sci* 115: 1441–1451, 2002.
687. Scott G, Liang H, and Luthra D. Stem cell factor regulates the melanocyte cytoskeleton. *Pigment Cell Res* 9: 134–141, 1996.
688. Sealy R, Hyde J, Felix C, Menon I, and Protta G. Eumelanins and phaeomelanins: characterization by electron spin resonance spectroscopy. *Science* 217: 545–547, 1982.
689. Sealy R, Hyde J, Felix C, Menon I, Protta G, Swartz H, Persad S, and Haberman H. Novel free radicals in synthetic and natural pheomelanins: distinction between dopa melanins and cysteinyl-dopa melanins by ESR spectroscopy. *Proc Natl Acad Sci USA* 79: 2885–2889, 1982.
690. Seiberg M, Paine C, Sharlow E, Andrade-Gordon P, Costanzo M, Eisinger M, and Shapiro SS. Inhibition of melanosome transfer results in skin lightening. *J Invest Dermatol* 115: 162–167, 2000.
691. Seidah NG, Chretien M, and Day R. The family of subtilisin/kexin like pro-protein and pro-hormone convertases: divergent or shared functions. *Biochimie* 76: 197–209, 1994.
692. Selaturi V. Sorting and targeting of melanosomal membrane proteins: signals, pathways, and mechanisms. *Pigment Cell Res* 13: 128–134, 2000.
694. Seuwen K and Pouyssegur J. Serotonin as a growth factor. *Biochem Pharmacol* 39: 985–990, 1990.
695. Shah MG and Maibach HI. Estrogen and skin. An overview. *Am J Clin Dermatol* 2: 143–150, 2001.
696. Shang J, Eberle J, Geilen CC, Hossini AM, Fecker LF, Orfanos CE, and Tebbe B. The role of nuclear factor-kappa B and

- melanogenesis in tumor necrosis factor- α -induced apoptosis of normal human melanocytes. *Skin Pharmacol Appl Skin Physiol* 15: 321–329, 2002.
697. **Sharov AA, Li GZ, Palkina TN, Sharova TY, Gilchrest BA, and Botchkarev VA.** Fas and *c-kit* are involved in the control of hair follicle melanocyte apoptosis and migration in chemotherapy-induced hair loss. *J Invest Dermatol* 120: 27–35, 2003.
 698. **Sharov AA, Weiner L, Sharova TY, Siebenhaar F, Atoyian R, Reginato AM, McNamara CA, Funa K, Gilchrest BA, Brissette JL, and Botchkarev VA.** Noggin overexpression inhibits eyelid opening by altering epidermal apoptosis and differentiation. *EMBO J* 22: 2992–3003, 2003.
 699. **Shaw HM, McGovern VJ, Milton GW, Farago GA, and McCarthy WH.** Malignant melanoma: influence of site of lesion and age of patient in the female superiority in survival. *Cancer* 46: 2731–2735, 1980.
 700. **Shibahara S, Taguchi H, Muller RM, Shibata K, Cohen T, Tomita Y, and Tagami H.** Structural organization of the pigment cell-specific gene located at the brown locus in mouse. Its promoter activity and alternatively spliced transcript. *J Biol Chem* 266: 15895–15901, 1991.
 701. **Shibahara S, Takeda K, Yasumoto K, Udono T, Watanabe K, Saito H, and Takahashi K.** Microphthalmia-associated transcription factor (MITF): multiplicity in structure, function, and regulation. *J Invest Dermatol Symp Proc* 6: 99–104, 2001.
 702. **Shibahara S, Tomita Y, Tagami H, Muller RM, and Cohen T.** Molecular basis for the heterogeneity of human tyrosinase. *Tohoku J Exp Med* 156: 403–414, 1988.
 703. **Shibata K, Muraosa Y, Tomita Y, Tagami H, and Shibahara S.** Identification of a *cis*-acting element that enhances the pigment cell-specific expression of the human tyrosinase gene. *J Biol Chem* 267: 20584–20588, 1992.
 704. **Shibata K, Takeda K, Tomita Y, Tagami H, and Shibahara S.** Downstream region of the human tyrosinase-related protein gene enhances its promoter activity. *Biochem Biophys Res Commun* 184: 568–575, 1992.
 705. **Shui-Wang Y, Niles LP, and Crocker C.** Human malignant melanoma cells express high-affinity receptors for melatonin: antiproliferative effects of melatonin and 6-chloromelatonin. *Eur J Pharmacol* 246: 89–96, 1993.
 706. **Shutter JR, Graham M, Kinsey AC, Scully S, Luthy R, and Stark KL.** Hypothalamic expression of ART, a novel gene related to agouti, is up-regulated in obese and diabetic mutant mice. *Genes Dev* 11: 593–602, 1997.
 707. **Siegrist W and Eberle AN.** Melanocortin and thier implication in melanoma. *Trends Endocrinol* 6: 115–120, 1995.
 708. **Silvers W.** *The Coat Colors of Mice. A Model for Mammalian Gene Action and Interaction.* New York: Springer Verlag, 1979.
 709. **Simoncini T, Hafezi-Moghadam A, Brazil DP, Ley K, Chin WW, and Liao JK.** Interaction of oestrogen receptor with the regulatory subunit of phosphatidylinositol-3-OH kinase. *Nature* 407: 538–541, 2000.
 710. **Simonson MS.** Endothelins: multifunctional renal peptides. *Physiol Rev* 73: 375–411, 1993.
 711. **Simonson MS and Dunn MJ.** Cellular signaling by peptides of the endothelin gene family. *FASEB J* 4: 2989–3000, 1990.
 712. **Slawinska D and Slawinski J.** Ultraweak photon emission in model reactions of the in vitro formation of eumelanins and pheomelanins. *Pigment Cell Res* 1: 171–175, 1987.
 713. **Slominski A.** Some properties of Bomirski Ab amelanotic melanoma cells, which underwent spontaneous melanization in primary cell culture. Growth kinetics, cell morphology, melanin content and tumorigenicity. *J Cancer Res Clin Oncol* 109: 29–37, 1985.
 714. **Slominski A.** Identification of β -endorphin, α -MSH and ACTH peptides in cultured human melanocytes, melanoma and squamous cell carcinoma cells. *Exp Dermatol* 7: 213–216, 1988.
 715. **Slominski A.** POMC gene expression in hamster and mouse melanoma cells. *FEBS Lett* 291: 165–168, 1991.
 716. **Slominski A.** Coming of age of melanogenesis-related proteins. *Arch Pathol Lab Med* 126: 775–777, 2002.
 717. **Slominski A, Baker J, Rosano T, Guisti LW, Ermak G, Grande M, and Gaudet SJ.** Metabolism of serotonin to *N*-acetylserotonin, melatonin, and 5-methoxytryptamine in hamster skin culture. *J Biol Chem* 271: 12281–12286, 1996.
 718. **Slominski A, Carlson A, Worstman J, and Mihm M Jr.** The role of molecular biology in diagnostic pathology of melanoma. *Methods Mol Med* 61: 123–163, 2001.
 719. **Slominski A, Chassalerris N, Mazurkiewicz J, and Paus R.** Murine skin as a target for melatonin bioregulation. *Exp Dermatol* 3: 45–50, 1994.
 720. **Slominski A and Costantino R.** L-Tyrosine induces tyrosinase expression via a posttranscriptional mechanism. *Experientia* 47: 721–725, 1991.
 721. **Slominski A and Costantino R.** Molecular mechanism of tyrosinase regulation by L-dopa in hamster melanoma cells. *Life Sci* 48: 2075–2079, 1991.
 722. **Slominski A, Costantino R, Howe J, and Moellmann G.** Molecular mechanisms governing melanogenesis in hamster melanomas: relative abundance of tyrosinase and catalase-B (gp 75). *Anticancer Res* 11: 257–262, 1991.
 723. **Slominski A, Costantino R, Wortsman J, Paus R, and Ling N.** Melanotropic activity of gamma MSH peptides in melanoma cells. *Life Sci* 50: 1103–1108, 1992.
 724. **Slominski A, Ermak G, Hwang J, Mazurkiewicz J, Corliss D, and Eastman A.** The expression of proopiomelanocortin (POMC) and of corticotropin releasing hormone receptor (CRH-R) genes in mouse skin. *Biochim Biophys Acta* 1289: 247–251, 1996.
 725. **Slominski A, Ermak G, and Mihm M.** ACTH receptor, CYP11A1, CYP17 and CYP21A2 genes are expressed in skin. *J Clin Endocrinol Metab* 81: 2746–2749, 1996.
 726. **Slominski A, Ermak G, and Wortsman J.** Modification of melanogenesis in cultured human melanoma cells. *In Vitro Cell Dev Biol* 35: 564–565, 1999.
 727. **Slominski A and Friedrich T.** L-DOPA inhibits in vitro phosphorylation of melanoma glycoproteins. *Pigment Cell Res* 5: 396–400, 1992.
 728. **Slominski A, Gomez-Sanchez C, Foecking MF, and Wortsman J.** Metabolism of progesterone to DOC, corticosterone and 18OHDOC in cultured human melanoma cells. *FEBS Lett* 445: 364–366, 1999.
 729. **Slominski A and Goodman-Snitkoff G.** DOPA inhibits induced proliferative activity of murine and human lymphocytes. *Anticancer Res* 12: 753–756, 1992.
 730. **Slominski A, Goodman-Snitkoff G, Maurer M, and Paus R.** Hair cycle-associated changes in splenocyte proliferation. *In Vivo* 11: 101–102, 1997.
 731. **Slominski A, Heasley D, Ermak G, Mazurkiewicz JE, Baker J, and Carlson A.** Expression of proopiomelanocortin (POMC) derived melanocyte stimulating hormone (MSH) and ACTH peptides in skin of basal cell carcinoma patients. *Hum Pathol* 30: 208–215, 1999.
 732. **Slominski A, Jastreboff P, and Pawelek J.** L-Tyrosine stimulates induction of tyrosinase activity by MSH and reduces cooperative interactions between MSH receptors in hamster melanoma cells. *Biosci Rep* 9: 579–586, 1989.
 733. **Slominski A, Moellmann G, and Kuklinska E.** MSH inhibits growth in a line of amelanotic hamster melanoma cells and induces increases in cAMP levels and tyrosinase activity without inducing melanogenesis. *J Cell Sci* 92: 551–559, 1989.
 734. **Slominski A, Moellmann G, and Kuklinska E.** L-Tyrosine, L-dopa and tyrosinase as positive regulators of the subcellular apparatus of melanogenesis in Bomirski Ab amelanotic melanoma. *Pigment Cell Res* 2: 109–116, 1989.
 735. **Slominski A, Moellman G, Kuklinska E, Bomirski A, and Pawelek J.** Positive regulation of melanin pigmentation by two key substrates of the melanogenic pathway: L-tyrosine and L-dopa. *J Cell Sci* 89: 287–296, 1988.
 736. **Slominski A and Paus R.** Are L-tyrosine and L-dopa hormone-like bioregulators. *J Theor Biol* 143: 123–138, 1990.
 737. **Slominski A and Paus R.** Bomirski melanomas: a versatile and powerful model for pigment cell and melanoma research. *Int J Oncol* 2: 221–228, 1993.
 738. **Slominski A and Paus R.** Melanogenesis is coupled to murine anagen: toward new concepts for the role of melanocytes and the

- regulation of melanogenesis in hair growth. *J Invest Dermatol* 101: 90S–97S, 1993.
739. **Slominski A and Paus R.** Towards defining receptors for L-tyrosine and L-DOPA. *Mol Cell Endocrinol* 99: C7–C11, 1994.
740. **Slominski A, Paus R, and Bomirski A.** Hypothesis: a possible role of the melatonin receptor in vitiligo. *J Roy Soc Med* 82: 539–541, 1989.
741. **Slominski A, Paus R, and Costantino R.** Differential expression and activity of melanogenesis-related proteins during induced hair growth in mice. *J Invest Dermatol* 96: 172–179, 1991.
742. **Slominski A, Paus R, and Mazurkiewicz J.** Proopiomelanocortin expression in the skin during induced hair growth in mice. *Experientia* 48: 50–54, 1992.
743. **Slominski A, Paus R, and Mihm M.** Inhibition of melanogenesis as an adjuvant strategy in the treatment of melanotic melanomas: selective review and hypothesis. *Anticancer Res* 18: 3709–3716, 1998.
744. **Slominski A, Paus R, Plonka P, Handjinski B, Maurer M, Chakraborty A, and Mihm M.** Pharmacological disruption of hair follicle pigmentation as a model for studying the melanocyte response to and recovery from cytotoxic damage in situ. *J Invest Dermatol* 106: 1203–1211, 1996.
745. **Slominski A, Paus R, Plonka P, Maurer M, Chakraborty A, Pruski D, and Lukiewicz S.** Melanogenesis during the anagen-catagen-telogen transformation of the murine hair cycle. *J Invest Dermatol* 102: 862–869, 1994.
746. **Slominski A, Paus R, and Schanderdorf D.** Melanocytes as sensory and regulatory cells in the epidermis. *J Theor Biol* 164: 103–120, 1993.
747. **Slominski A and Pawelek J.** Animals under the sun: effects of UV radiation on mammalian skin. *Clin Dermatol* 16: 503–515, 1998.
748. **Slominski A and Pawelek J.** MSH binding in Bomirski amelanotic melanoma cells is stimulated by L-tyrosine. *Biosci Rep* 7: 949–954, 1987.
749. **Slominski A, Pisarchik A, Johansson O, Jing C, Semak I, Slugocki G, and Wortsman J.** Tryptophan hydroxylase (TPH) expression in human skin cells. *Biochim Biophys Acta* 1639: 80–86, 2003.
750. **Slominski A, Pisarchik A, Semak I, Sweatman T, Szczesniowski A, and Wortsman J.** Serotonergic system in hamster skin. *J Invest Dermatol* 119: 934–942, 2002.
751. **Slominski A, Pisarchik A, Semak I, Sweatman T, and Wortsman J.** Characterization of the serotonergic system in the C57BL/6 mouse skin. *Eur J Biochem* 270: 3335–3344, 2003.
752. **Slominski A, Pisarchik A, Semak I, Sweatman T, Wortsman J, Szczesniowski A, Slugocki G, McNulty J, Kauser S, and Tobin DJ.** Serotonergic and melatonergic systems are fully expressed in human skin. *FASEB J* 16: 896–898, 2002.
753. **Slominski A, Pisarchik A, Zbytek B, Tobin DJ, Kauser S, and Wortsman J.** Functional activity of serotonergic and melatonergic systems expressed in the skin. *J Cell Physiol* 196: 144–153, 2003.
754. **Slominski A and Pruski D.** L-DOPA binding sites in rodent melanoma cells. *Biochem Biophys Acta* 1139: 324–328, 1992.
755. **Slominski A and Pruski D.** Melatonin inhibits proliferation and melanogenesis in rodent melanoma cells. *Exp Cell Res* 206: 189–294, 1993.
756. **Slominski A, Roloff B, Zbytek B, Wei ET, Fechner K, Curry J, and Wortsman J.** Corticotropin releasing hormone (CRH) and related peptides can act as bioregulatory factors in human keratinocytes. *In Vitro Cell Dev Biol* 36: 211–216, 2000.
757. **Slominski A, Semak I, Pisarchik A, Sweatman T, Szczesniowski A, and Wortsman J.** Conversion of L-tryptophan to serotonin and melatonin in melanoma cells. *FEBS Lett* 511: 102–106, 2002.
758. **Slominski A, Szczesniowski A, and Wortsman J.** Liquid chromatography-mass spectrometry detection of corticotropin-releasing hormone and proopiomelanocortin-derived peptides in human skin. *J Clin Endocrinol Metab* 85: 3582–3588, 2000.
759. **Slominski A and Wortsman J.** Neuroendocrinology of the skin. *Endocr Rev* 21: 457–487, 2000.
760. **Slominski A, Wortsman J, Carlson A, Matsuoka L, Balch CM, and Mihm M.** Malignant melanoma: an update. *Arch Pathol Lab Med* 125: 1295–1306, 2001.
761. **Slominski A, Wortsman J, Kohn L, Ain KB, Venkataraman GM, Pisarchik A, Chung JH, Giuliani C, Thornton M, Slugocki G, and Tobin DJ.** Expression of hypothalamic-pituitary-thyroid axis related genes in the human skin. *J Invest Dermatol* 119: 1449–1455, 2002.
762. **Slominski A, Wortsman J, Luger T, Paus R, and Salomon S.** Corticotropin releasing hormone and proopiomelanocortin involvement in the cutaneous response to stress. *Physiol Rev* 80: 979–1020, 2000.
763. **Slominski A, Wortsman J, Mazurkiewicz J, Matsuoka L, Lawrence K, and Paus R.** Detection of the proopiomelanocortin-derived antigens in normal and pathologic human skin. *J Lab Clin Med* 122: 658–666, 1993.
764. **Smit N, Le Poole I, van den Wijngaard R, Tigges A, Westerhof W, and Das P.** Expression of different immunological markers by cultured human melanocytes. *Arch Dermatol Res* 285: 356–365, 1993.
765. **Smit N, Tilgmann C, Karhunen T, Slingerland R, Ulmanen I, Westerhof W, and Pavel S.** O-methylation of L-dopa in melanin metabolism and the presence of catechol-O-methyltransferase in melanocytes. *Pigment Cell Res* 7: 403–408, 1994.
766. **Smith C and Cerundolo V.** Immunotherapy of melanoma. *Immunology* 104: 1–7, 2001.
767. **Smith T, Clark JW, and Popp MB.** Regression of melanoma nodules in a patient treated with ranitidine. *Arch Intern Med* 147: 1815–1816, 1987.
768. **Smith TJ and Kline EL.** 3,3',5-L-Triiodothyronine but not L-thyroxine can block the induction of tyrosinase by imidazole in cultured B16 melanoma cells. *Biochem Biophys Res Commun* 155: 1293–1296, 1988.
769. **Smith TJ and Kline EL.** Multi-hormonal regulation of tyrosinase expression in B16/C3 melanoma cells in culture. *Prog Clin Biol Res* 262: 241–255, 1988.
770. **Smith TJ, Warren JT Jr, and Kline EL.** Retinoic acid blockade of imidazole-induced tyrosinase expression in B16 melanoma cultures: similar effects of the active retinoid and triiodothyronine. *Biochem Biophys Res Commun* 162: 288–293, 1989.
771. **Snell RS.** The pigmentary changes occurring in the breast skin during pregnancy and following estrogen treatment. *J Invest Dermatol* 43: 181–186, 1964.
772. **Soberman RJ and Christmas P.** The organization and consequences of eicosanoid signaling. *J Clin Invest* 111: 1107–1113, 2003.
773. **Solano F, Martinez-Esparza M, Jimenez-Cervantes C, Hill SP, Lozano JA, and Garcia-Borron JC.** New insights on the structure of the mouse silver locus and on the function of the silver protein. *Pigment Cell Res* 13 Suppl 8: 118–124, 2000.
774. **Solca F, Siegrist W, Drozd R, Girard J, and Eberle AN.** The receptor for alpha-melanotropin of mouse and human melanoma cells. Application of a potent alpha-melanotropin photoaffinity label. *J Biol Chem* 264: 14277–14281, 1989.
775. **Sonesson B, Rosengren E, Hansson AS, and Hansson C.** UVB-induced inflammation gives increased D-dopachrome tautomerase activity in blister fluid which correlates with macrophage migration inhibitory factor. *Exp Dermatol* 12: 278–282, 2003.
776. **Spanjaard RA, Ikeda M, Lee PJ, Charpentier B, Chin WW, and Eberlein TJ.** Specific activation of retinoic acid receptors (RARs) and retinoid X receptors reveals a unique role for RARgamma in induction of differentiation and apoptosis of S91 melanoma cells. *J Biol Chem* 272: 18990–18999, 1997.
777. **Spark RF.** Dehydroepiandrosterone: a springboard hormone for female sexuality. *Fertil Steril* 77 Suppl 4: 19–25, 2002.
778. **Spritz RA.** Molecular basis of human piebaldism. *J Invest Dermatol* 103: 137S–140S, 1994.
779. **Spritz RA.** Multi-organellar disorders of pigmentation: intracellular traffic jams in mammals, flies and yeast. *Trends Genet* 15: 337–340, 1999.
780. **Spritz RA.** Multi-organellar disorders of pigmentation: tied up in traffic. *Clin Genet* 55: 309–317, 1999.
781. **Spritz RA, Holmes SA, Ramesar R, Greenberg J, Curtis D, and Beighton P.** Mutations of the KIT (mast/stem cell growth factor

- receptor) proto-oncogene account for a continuous range of phenotypes in human piebaldism. *Am J Hum Genet* 51: 1058–1065, 1992.
782. **Stanka P, Kinzel V, and Mohr U.** Elektronenmikroskopische untersuchung uber die pramelanosomenentstehung an melanomzellen in vitro. *Virchows Arch Abt B Zellpath* 2: 91–102, 1969.
783. **Staricco RG.** Amelanotic melanocytes in the outer sheath of the human hair follicle and their role in the repigmentation of regenerated epidermis. *Ann NY Acad Sci* 100: 239–255, 1963.
784. **Stastny J, Konstantinidis A, Schwarz MJ, Rosenthal NE, Vitouch O, Kasper S, and Neumeister A.** Effects of tryptophan depletion and catecholamine depletion on immune parameters in patients with seasonal affective disorder in remission with light therapy. *Biol Psychiatry* 53: 332–337, 2003.
785. **Steel KP, Davidson DR, and Jackson IJ.** TRP-2/DT, a new early melanoblast marker, shows that steel growth factor (*c-kit* ligand) is a survival factor. *Development* 115: 1111–1119, 1992.
786. **Steinkraus V, Steinfath M, Korner C, and Mensing H.** Binding of beta-adrenergic receptors in human skin. *J Invest Dermatol* 98: 475–480, 1992.
787. **Stepien KB, Dworzanski JP, Bilinska B, Porebska-Budny M, Hollek AM, and Wilczok T.** Catecholamin melanins. Structural changes induced by copper ions. *Biochim Biophys Acta* 997: 49–54, 1989.
788. **Stewart DG and Lewis HM.** Vitamin D analogues and psoriasis. *J Clin Pharm Ther* 21: 143–148, 1996.
789. **Stoney CM and Hughes JW.** Catecholamine stress responses in arterialized blood. *Psychophysiology* 38: 590–593, 2001.
790. **Stryer L.** *Biochemistry*. New York: Freeman, 1988.
791. **Stumpf WE, Clark SA, Sar M, and DeLuca HF.** Topographical and developmental studies on target sites of 1,25 (OH)₂ vitamin D₃ in skin. *Cell Tissue Res* 238: 489–496, 1984.
792. **Sturm RA, Teasdale RD, and Box NF.** Human pigmentation genes: identification, structure and consequences of polymorphic variation. *Gene* 277: 49–62, 2001.
793. **Sugden D, Cena V, and Klein DC.** Hydroxyindole O-methyltransferase. *Methods Enzymol* 142: 590–596, 1987.
794. **Sugiyama S.** Mode of redifferentiation and melanogenesis of melanocytes in mouse hair follicles. An ultrastructural and cytochemical study. *J Ultrastruct Res* 67: 40–54, 1979.
795. **Sugiyama S, Saga K, Morimoto Y, and Takahashi M.** Proliferating activity of the hair follicular melanocytes at the early and anagen III stages in the hair growth cycle: detection by immunocytochemistry for bromodeoxyuridine combined with DOPA reaction cytochemistry. *J Dermatol* 22: 396–402, 1995.
796. **Sukhanov VA, Voronkova IM, Shvets SV, Dyakov VL, and Morozova LF.** Melanocyte-stimulating hormone (alpha-MSH) inhibits the growth of human malignant melanoma cells with the induction of phosphatidylinositol and myo-inositol phosphate levels. *Biochem Int* 24: 625–632, 1991.
797. **Suzuki H, Takahashi K, Yasumoto K, Amae S, Yoshizawa M, Fuse N, and Shibahara S.** Role of neurofibromin in modulation of expression of the tyrosinase-related protein 2 gene. *J Biochem* 124: 992–998, 1998.
798. **Suzuki I, Cone RD, Im S, Nordlund J, and Abdel-Malek ZA.** Binding of melanotropic hormones to the melanocortin receptor MC1R on human melanocytes stimulates proliferation and melanogenesis. *Endocrinology* 137: 1627–1633, 1996.
799. **Swerdlow NR, Shoemaker JM, Auerbach PP, Pitcher L, Goins J, and Platten A.** Heritable differences in the dopaminergic regulation of sensorimotor gating. II. Temporal, pharmacologic and generational analyses of apomorphine effects on prepulse inhibition. *Psychopharmacology* 2003.
800. **Swope VB, Abdel-Malek Z, Kassem LM, and Nordlund JJ.** Interleukins 1 alpha and 6 and tumor necrosis factor-alpha are paracrine inhibitors of human melanocyte proliferation and melanogenesis. *J Invest Dermatol* 96: 180–185, 1991.
801. **Swope VB, Sauder DN, McKenzie RC, Sramkoski RM, Krug KA, Babcock GF, Nordlund JJ, and Abdel-Malek ZA.** Synthesis of interleukin-1 alpha and beta by normal human melanocytes. *J Invest Dermatol* 102: 749–753, 1994.
802. **Syrris P, Heathcote K, Carrozzo R, Devriendt K, Elcioglu N, Garrett C, McEntagart M, and Carter ND.** Human piebaldism: six novel mutations of the proto-oncogene KIT. *Hum Mutat* 20: 234, 2002.
803. **Szabo G.** The regional anatomy of the human integument with special reference to the distribution of hair follicles, sweat glands and melanocytes. *Philos Trans R Soc Lond Ser B* 252: 447–489, 1967.
804. **Szincsak N, Hegyesi H, Hunyadi J, Martin G, Lazar-Molnar E, Kovacs P, Rivera E, Falus A, and Juhasz I.** Cimetidine and a tamoxifen derivate reduce tumour formation in SCID mice xenotransplanted with a human melanoma cell line. *Melanoma Res* 12: 231–240, 2002.
805. **Tachibana T, Taniguchi S, Fujiwara M, and Imamura S.** Regulation of the activity of histamine-N-methyltransferase from guinea pig skin by biogenic amines. *Exp Mol Pathol* 45: 257–269, 1986.
806. **Tada A, Suzuki I, Im S, Davis MB, Cornelius J, Babcock G, Nordlund JJ, and Abdel-Malek ZA.** Endothelin-1 is a paracrine growth factor that modulates melanogenesis of human melanocytes and participates in their responses to ultraviolet radiation. *Cell Growth Differ* 9: 575–584, 1998.
807. **Tadokoro T, Itami S, Hosokawa K, Terashi H, and Takayasu S.** Human genital melanocytes as androgen target cells. *J Invest Dermatol* 109: 513–517, 1997.
808. **Takechi Y, Hara I, Naftzger C, Xu Y, and Houghton AN.** A melanosomal membrane protein is a cell surface target for melanoma therapy. *Clin Cancer Res* 2: 1837–1842, 1996.
809. **Takeda A, Tomita Y, Matsunaga J, Tagami H, and Shibahara S.** Molecular basis of tyrosinase-negative oculocutaneous albinism. A single base mutation in the tyrosinase gene causing arginine to glutamine substitution at position 59. *J Biol Chem* 265: 17792–17797, 1990.
810. **Takeda K, Yasumoto K, Kawaguchi N, Udono T, Watanabe K, Saito H, Takahashi K, Noda M, and Shibahara S.** Mitf-D, a newly identified isoform, expressed in the retinal pigment epithelium and monocyte-lineage cells affected by Mitf mutations. *Biochim Biophys Acta* 1574: 15–23, 2002.
811. **Talley NJ.** Serotonergic neuroenteric modulators. *Lancet* 358: 2061–2068, 2001.
812. **Talwar HS, Griffiths CE, Fisher GJ, Russman A, Krach K, Benrazavi S, and Voorhees JJ.** Differential regulation of tyrosinase activity in skin of white and black individuals in vivo by topical retinoic acid. *J Invest Dermatol* 100: 800–805, 1993.
813. **Tamate HB and Takeuchi T.** Action of the e locus of mice in the response of phaeomelanin hair follicles to alpha-melanocyte-stimulating hormone in vitro. *Science* 224: 1241–1242, 1984.
814. **Tartaglia LA, Weber RF, Figari IS, Reynolds C, Palladino MA Jr, and Goeddel DV.** The two different receptors for tumor necrosis factor mediate distinct cellular responses. *Proc Natl Acad Sci USA* 88: 9292–9296, 1991.
815. **Tassabehji M, Metcalfe K, Karmiloff-Smith A, Carette MJ, Grant J, Dennis N, Reardon W, Splitt M, Read AP, and Donnai D.** Williams syndrome: use of chromosomal microdeletions as a tool to dissect cognitive and physical phenotypes. *Am J Hum Genet* 64: 118–125, 1999.
816. **Tassabehji M, Read AP, Newton VE, Harris R, Balling R, Gruss P, and Strachan T.** Waardenburg's syndrome patients have mutations in the human homologue of the Pax-3 paired box gene. *Nature* 355: 635–636, 1992.
817. **Tassabehji M, Read AP, Newton VE, Patton M, Gruss P, Harris R, and Strachan T.** Mutations in the PAX3 gene causing Waardenburg syndrome type 1 and type 2. *Nat Genet* 3: 26–30, 1993.
818. **Tau G and Rothman P.** Biologic functions of the IFN-gamma receptors. *Allergy* 54: 1233–1251, 1999.
819. **Tenchini ML, Morra F, Soranzo C, and Malcovati M.** Effects of keratinocyte-secreted soluble factors on spreading, number of dendrites and cell-cell contacts of human epidermal melanocytes and dermal fibroblasts: a quantitative analysis. *Epithelial Cell Biol* 4: 143–155, 1995.
820. **Thody AJ.** Epidermal melanocytes: their regulation and role in skin pigmentation. *Eur J Dermatol* 5: 558–565, 1995.

821. **Thody AJ, Ridley K, Penny RJ, Chalmers R, Fisher C, and Shuster S.** MSH peptides are present in mammalian skin. *Peptides* 4: 813–816, 1983.
822. **Thomas P, Dalle E, Revillon B, Delecour M, Devarenne-nicolle MF, and Pagniez I.** Cutaneous effects in hormonal contraception. *NPN Med* 5: 19–24, 1985.
823. **Thony B, Auerbach G, and Blau N.** Tetrahydrobiopterin biosynthesis, regeneration and functions. *Biochem J* 347: 1–16, 2000.
824. **Thornton MJ.** The biological actions of estrogens on skin. *Exp Dermatol* 11: 487–502, 2002.
825. **Thornton MJ, Taylor AH, Mulligan K, Al-Azzawi F, Lyon CC, O'Driscoll J, and Messenger AG.** Oestrogen receptor beta is the predominant oestrogen receptor in human scalp skin. *Exp Dermatol* 12: 181–190, 2003.
826. **Tief K, Schmidt A, and Beermann F.** New evidence for presence of tyrosinase in substantia nigra, forebrain and midbrain. *Brain Res* 53: 307–310, 1998.
827. **Tilly BC, Tertoolen LG, Remorie R, Ladoux A, Verlaan I, de Laet SW, and Moolenaar WH.** Histamine as a growth factor and chemoattractant for human carcinoma and melanoma cells: action through Ca²⁺(+)-mobilizing H1 receptors. *J Cell Biol* 110: 1211–1215, 1990.
828. **Tobin DJ and Bystryn JC.** Different populations of melanocytes are present in hair follicles and epidermis. *Pigment Cell Res* 9: 304–310, 1996.
829. **Tobin DJ, Colen SR, and Bystryn JC.** Isolation and long-term culture of human hair-follicle melanocytes. *J Invest Dermatol* 104: 86–89, 1995.
830. **Tobin DJ, Hagen E, Botchkarev VA, and Paus R.** Do hair bulb melanocytes undergo apoptosis during hair follicle regression (catagen)? *J Invest Dermatol* 111: 941–947, 1998.
831. **Tobin DJ and Paus R.** Graying: gerontology of the hair follicle pigimentary unit. *Exp Gerontol* 36: 29–54, 2001.
832. **Tobin DJ, Slominski A, Botchkarev V, and Paus R.** The fate of hair follicle melanocytes during the hair growth in mice. *J Invest Dermatol Symp Proc* 4: 323–332, 1999.
833. **Toffolon EP, Pechet MM, and Isselbacher K.** Demonstration of the rapid action of pure crystalline 1 alpha-hydroxy vitamin D₃ and 1 alpha,25-dihydroxy vitamin D₃ on intestinal calcium uptake. *Proc Natl Acad Sci USA* 72: 229–230, 1975.
834. **Tomita Y, Maeda K, and Tagami H.** Leukotrienes and thromboxane B₂ stimulate normal human melanocytes in vitro: possible inducers of postinflammatory pigmentation. *Tohoku J Exp Med* 156: 303–304, 1988.
835. **Tomita Y, Maeda K, and Tagami H.** Mechanisms for hyperpigmentation in postinflammatory pigmentation, urticaria pigmentosa and sunburn. *Dermatologica* 179 Suppl 1: 49–53, 1989.
836. **Tomita Y, Maeda K, and Tagami H.** Melanocyte-stimulating properties of arachidonic acid metabolites: possible role in postinflammatory pigmentation. *Pigment Cell Res* 5: 357–361, 1992.
837. **Tomita Y, Maeda K, and Tagami H.** Stimulatory effect of histamine on normal human melanocytes in vitro. *Tohoku J Exp Med* 155: 209–210, 1988.
838. **Tomita Y, Takeda A, Okinaga S, Tagami H, and Shibahara S.** Human oculocutaneous albinism caused by single base insertion in the tyrosinase gene. *Biochem Biophys Res Commun* 164: 990–996, 1989.
839. **Tomita Y, Torinuki W, and Tagami H.** Stimulation of human melanocytes by vitamin D₃ possibly mediates skin pigmentation after sun exposure. *J Invest Dermatol* 90: 882–884, 1988.
840. **Toyofuku K, Valencia JC, Kushimoto T, Costin GE, Virador VM, Vieira WD, Ferrans VJ, and Hearing VJ.** The etiology of oculocutaneous albinism (OCA) type II: the pink protein modulates the processing and transport of tyrosinase. *Pigment Cell Res* 15: 217–224, 2002.
841. **Toyofuku K, Wada I, Spritz RA, and Hearing VJ.** The molecular basis of oculocutaneous albinism type I (OCA1): sorting failure and degradation of mutant tyrosinases results in a lack of pigmentation. *Biochem J* 355: 259–269, 2001.
842. **Toyofuku K, Wada I, Valencia JC, Kushimoto T, Ferrans VJ, and Hearing VJ.** Oculocutaneous albinism types 1 and 3 are ER retention diseases: mutation of tyrosinase or Tyrp1 can affect the processing of both mutant and wild-type proteins. *FASEB J* 15: 2149–2161, 2001.
843. **Tsukamoto K, Jackson IJ, Urabe K, Montague PM, and Hearing VJ.** A second tyrosinase-related protein, TRP-2, is a melanogenic enzyme termed DOPachrome tautomerase. *EMBO J* 11: 519–526, 1992.
844. **Tsukamoto K, Ueda M, and Hearing VJ.** Melanogenesis in murine melanocytes is suppressed by infection with the v-rasHa oncogene. *Pigment Cell Res Suppl* 2: 181–184, 1992.
845. **Ucar K.** The effects of histamine H₂ receptor antagonists on melanogenesis and cellular proliferation in melanoma cells in culture. *Biochem Biophys Res Commun* 177: 545–550, 1991.
846. **Udono T, Takahashi K, Yasumoto K, Yoshizawa M, Takeda K, Abe T, Tamai M, and Shibahara S.** Expression of tyrosinase-related protein 2/DOPachrome tautomerase in the retinoblastoma. *Exp Eye Res* 72: 225–234, 2001.
847. **Ueda T, Mawji NR, Bruchovsky N, and Sadar MD.** Ligand-independent activation of the androgen receptor by interleukin-6 and the role of steroid receptor coactivator-1 in prostate cancer cells. *J Biol Chem* 277: 38087–38094, 2002.
848. **Ullrich A and Schlessinger J.** Signal transduction by receptors with tyrosine kinase activity. *Cell* 61: 203–212, 1990.
849. **Vale RD.** The molecular motor toolbox for intracellular transport. *Cell* 112: 467–480, 2003.
850. **Valverde P, Benedito E, Solano F, Oaknin S, Lozano JA, and Garcia-Borrón JC.** Melatonin antagonizes alpha-melanocyte-stimulating hormone enhancement of melanogenesis in mouse melanoma cells by blocking the hormone-induced accumulation of the c locus tyrosinase. *Eur J Biochem* 232: 257–263, 1995.
851. **Valverde P, Healy E, Jackson I, Rees JL, and Thody AJ.** Variants of the melanocyte-stimulating hormone receptor gene are associated with red hair and fair skin in humans. *Nat Genet* 11: 328–330, 1995.
852. **Valverde P, Healy E, Sikkink S, Haldane F, Thody AJ, Carothers A, Jackson IJ, and Rees JL.** The Asp84Glu variant of the melanocortin 1 receptor (MC1R) is associated with melanoma. *Hum Mol Genet* 5: 1663–1666, 1996.
853. **Vancoillie G, Lambert J, Mulder A, Koerten HK, Mommaas AM, Van Oostveldt P, and Naeyaert JM.** Kinesin and kinectin can associate with the melanosomal surface and form a link with microtubules in normal human melanocytes. *J Invest Dermatol* 114: 421–429, 2000.
854. **Van Niekerk CH and Prinsloo AE.** Effect of skin pigmentation on the response to intradermal histamine. *Int Arch Allergy Appl Immunol* 76: 73–75, 1985.
855. **Varga JM, Dipasquale A, Pawelek J, McGuire JS, and Lerner AB.** Regulation of melanocyte stimulating hormone action at the receptor level: discontinuous binding of hormone to synchronized mouse melanoma cells during the cell cycle. *Proc Natl Acad Sci USA* 71: 1590–1593, 1974.
856. **Varga JM, Moellmann G, Fritsch P, Godawska E, and Lerner AB.** Association of cell surface receptors for melanotropin with the Golgi region in mouse melanoma cells. *Proc Natl Acad Sci USA* 73: 559–562, 1976.
857. **Varley JE and Maxwell GD.** BMP-2 and BMP-4, but not BMP-6, increase the number of adrenergic cells which develop in quail trunk neural crest cultures. *Exp Neurol* 140: 84–94, 1996.
858. **Vaughan JM, Fischer WH, Hoeger C, Rivier J, and Vale W.** Characterization of melanin-concentrating hormone from rat hypothalamus. *Endocrinology* 125: 1660–1665, 1989.
859. **Vennegoer C, Hageman P, Van Nouhuijs H, Ruiter DJ, Calafat J, Ringens PJ, and Rumke P.** A monoclonal antibody specific for cells of the melanocyte lineage. *Am J Pathol* 130: 179–192, 1988.
860. **Verastegui C, Bertolotto C, Bille K, Abbe P, Ortonne JP, and Ballotti R.** TFE₃, a transcription factor homologous to microphthalmia, is a potential transcriptional activator of tyrosinase and Tyrp1 genes. *Mol Endocrinol* 14: 449–456, 2000.
861. **Verschoore M.** Hyperandrogenism and pilosebaceous follicles. *Rev Prat* 43: 2363–2369, 1993.
862. **Viac J, Vincent C, Palacio S, Schmitt D, and Claudy A.** Tumour necrosis factor (TNF) soluble receptors in malignant melanoma: correlation with soluble ICAM-1 levels. *Eur J Cancer* 32: 447–449, 1996.

863. **Vink T, Hinney A, van Elburg AA, van Goozen SH, Sandkuijl LA, Sinke RJ, Herpertz-Dahlmann BM, Hebebrand J, Remschmidt H, van Engeland H, and Adan RA.** Association between an agouti-related protein gene polymorphism and anorexia nervosa. *Mol Psychiatry* 6: 325–328, 2001.
864. **Voorhees JJ.** Leukotrienes and other lipoxygenase products in the pathogenesis and therapy of psoriasis and other dermatoses. *Arch Dermatol* 119: 541–547, 1983.
865. **Vrieling H, Duhl DM, Millar SE, Miller KA, and Barsh GS.** Differences in dorsal and ventral pigmentation result from regional expression of the mouse agouti gene. *Proc Natl Acad Sci USA* 91: 5667–5671, 1994.
866. **Wakamatsu K, Graham A, Cook D, and Thody AJ.** Characterisation of ACTH peptides in human skin and their activation of the melanocortin-1 receptor. *Pigment Cell Res* 10: 288–297, 1997.
867. **Wand M.** Latanoprost and hyperpigmentation of eyelashes. *Arch Ophthalmol* 115: 1206–1208, 1997.
868. **Wang Y, Aisen P, and Casadevall A.** *Cryptococcus neoformans* melanin and virulence: mechanism of action. *Infect Immun* 63: 3131–3136, 1995.
869. **Wankowicz-Kalinska A, Le Poole C, van den Wijngaard R, Storkus WJ, and Das PK.** Melanocyte-specific immune response in melanoma and vitiligo: two faces of the same coin? *Pigment Cell Res* 16: 254–260, 2003.
870. **Warren R.** Sensitivity of mouse Skh-HR-2 to ultraviolet light: mouse pigmentation model. *Photochem Photobiol* 43: 41–47, 1986.
871. **Watabe H, Soma Y, Kawa Y, Ito M, Ooka S, Ohsumi K, Baba T, Kawakami T, Hosaka E, Kimura S, and Mizoguchi M.** Differentiation of murine melanocyte precursors induced by 1,25-dihydroxyvitamin D₃ is associated with the stimulation of endothelin B receptor expression. *J Invest Dermatol* 119: 583–589, 2002.
872. **Watanabe T, Timmerman H, and Yanai K.** *Histamine Research in the New Millennium*. Amsterdam: Excerpta Medica, 2001.
873. **Waterland RA and Jirtle RL.** Transposable elements: targets for early nutritional effects on epigenetic gene regulation. *Mol Cell Biol* 23: 5293–5300, 2003.
874. **Weatherhead B.** The pineal gland and pigmentation. In: *The Physiology and Pathophysiology of the Skin*, edited by Jarrett A. New York: Academic, 1982, p. 2165–2179.
875. **Weatherhead B and Logan A.** Interaction of alpha-melanocyte-stimulating hormone, melatonin, cyclic AMP and cyclic GMP in the control of melanogenesis in hair follicle melanocytes in vitro. *J Endocrinol* 90: 89–96, 1981.
876. **Webb AR, Kline L, and Holick MF.** Influence of season and latitude on the cutaneous synthesis of vitamin D₃: exposure to winter sunlight in Boston and Edmonton will not promote vitamin D₃ synthesis in human skin. *J Clin Endocrinol Metab* 67: 373–378, 1988.
877. **Webb AR, Pilbeam C, Hanafin N, and Holick MF.** An evaluation of the relative contributions of exposure to sunlight and of diet to the circulating concentrations of 25-hydroxyvitamin D in an elderly nursing home population in Boston. *Am J Clin Nutr* 51: 1075–1081, 1990.
878. **Weedon D and Strutton G.** Apoptosis as the mechanism of the involution of hair follicles in catagen transformation. *Acta Derm Venereol* 61: 335–339, 1981.
879. **Wehrle-Haller B and Weston JA.** Soluble and cell-bound forms of steel factor activity play distinct roles in melanocyte precursor dispersal and survival on the lateral neural crest migration pathway. *Development* 121: 731–742, 1995.
880. **Wehrle-Haller B and Weston JA.** Altered cell-surface targeting of stem cell factor causes loss of melanocyte precursors in Steel17H mutant mice. *Dev Biol* 210: 71–86, 1999.
881. **Wei Q, Wu X, and Hammer JA III.** The predominant defect in dilute melanocytes is in melanosome distribution and not cell shape, supporting a role for myosin V in melanosome transport. *J Muscle Res Cell Motil* 18: 517–527, 1997.
882. **Weinstein GD, Nigra TP, Pochi PE, Savin RC, Allan A, Benik K, Jeffes E, Lufrano L, and Thorne EG.** Topical tretinoin for treatment of photodamaged skin. A multicenter study. *Arch Dermatol* 127: 659–665, 1991.
883. **Wells L.** Pigmentation of the scrotum as a sensitive indicator for androgen. *Anat Rec* 91: 305–306, 1944.
884. **Wess J.** Molecular basis of receptor/G-protein-coupling selectivity. *Pharmacol Ther* 80: 231–264, 1998.
885. **Westbroek W, Lambert J, and Naeyaert JM.** The dilute locus and Griscelli syndrome: gateways towards a better understanding of melanosome transport. *Pigment Cell Res* 14: 320–327, 2001.
886. **Westgate GE, Craggs RI, and Gibson WT.** Immune privilege in hair growth. *J Invest Dermatol* 97: 417–420, 1991.
887. **Whitehead RJ, Taylor DJ, Evanson JM, Hart IR, and Woolley DE.** Demonstration of histamine H₂ receptors on human melanoma cells. *Biochem Biophys Res Commun* 151: 518–523, 1988.
888. **Wick MM.** Therapeutic effect of dopamine infusion on human malignant melanoma. *Cancer Treat Rep* 66: 1657–1659, 1982.
889. **Widlund HR and Fisher DE.** Microphthalmia-associated transcription factor: a critical regulator of pigment cell development and survival. *Oncogene* 22: 3035–3041, 2003.
890. **Willems E, Knigge U, Jorgensen H, Kjaer A, and Warberg J.** Effect of blockade of postsynaptic H1 or H2 receptors or activation of presynaptic H3 receptors on catecholamine-induced stimulation of ACTH and prolactin secretion. *Eur J Endocrinol* 142: 637–641, 2000.
891. **Willems M, Munte K, Vrolijk JM, Den Hollander JC, Bohm M, Kemmeren MH, De Man RA, and Brouwer JT.** Hyperpigmentation during interferon-alpha therapy for chronic hepatitis C virus infection. *Br J Dermatol* 149: 390–394, 2003.
892. **Wilson BD, Ollmann MM, Kang L, Stoffel M, Bell GI, and Barsh GS.** Structure and function of ASP, the human homolog of the mouse agouti gene. *Hum Mol Genet* 4: 223–230, 1995.
893. **Wilson MJ and Spaziani E.** The melanogenic response to testosterone in scrotal epidermis: effects on tyrosinase activity and protein synthesis. *Acta Endocrinol* 81: 435–448, 1976.
894. **Wilson SG, Retallack RW, Kent JC, Worth GK, and Gutteridge DH.** Serum free 1,25-dihydroxyvitamin D and the free 1,25-dihydroxyvitamin D index during a longitudinal study of human pregnancy and lactation. *Clin Endocrinol* 32: 613–622, 1990.
895. **Winder AJ and Harris H.** Induction of tyrosinase in human melanoma cells by L-tyrosine phosphate and cytochalasin D. *Exp Cell Res* 199: 248–254, 1992.
896. **Wintzen M, Yaar M, Burbach JPH, and Gilchrist BA.** Proopiomelanocortin gene product regulation in keratinocytes. *J Invest Dermatol* 106: 673–678, 1996.
897. **Wolff GL.** Regulation of yellow pigment formation in mice: a historical perspective. *Pigment Cell Res* 16: 2–15, 2003.
898. **Wolff GL, Galbraith DB, Doman OE, and Row JM.** Pheomelanin synthesis and obesity in mice. Interaction of the viable yellow (*Avy*) and sombre (*eso*) mutations. *J Hered* 69: 295–298, 1978.
899. **Wong G and Pawelek J.** Control of phenotypic expression of cultured melanoma cells by melanocyte stimulating hormones. *Nat New Biol* 241: 213–215, 1973.
900. **Wong G and Pawelek J.** Melanocyte-stimulating hormone promotes activation of pre-existing tyrosinase molecules in Cloudman S91 melanoma cells. *Nature* 255: 644–646, 1975.
901. **Wong G, Pawelek J, Sansone M, and Morowitz J.** Response of mouse melanoma cells to melanocyte stimulating hormone. *Nature* 248: 351–354, 1974.
902. **Wood JM, Jimbow K, Boissy RE, Slominski A, Plonka PM, Slawinski J, Wortsman J, and Tosk J.** What's the use of generating melanin? *Exp Dermatol* 8: 153–164, 1999.
903. **Wood JM and Schallreuter KU.** Studies on the reactions between human tyrosinase, superoxide anion, hydrogen peroxide and thiols. *Biochim Biophys Acta* 1074: 378–385, 1991.
904. **Wood JM, Schallreuter-Wood KU, Lindsey NJ, Callaghan S, and Gardner ML.** A specific tetrahydrobiopterin binding domain on tyrosinase controls melanogenesis. *Biochem Biophys Res Commun* 206: 480–485, 1995.
905. **Wozney JM.** Overview of bone morphogenetic proteins. *Spine* 27: S2–S8, 2002.
906. **Wright MR and Lerner AB.** On the movement of pigment granules in frog melanocytes. *Endocrinology* 66: 559–609, 1960.
907. **Wu PC, Alexander HR, Huang J, Hwu P, Gnant M, Berger AC, Turner E, Wilson O, and Libutti SK.** In vivo sensitivity of human melanoma to tumor necrosis factor (TNF)-alpha is determined by tumor production of the novel cytokine endothelial-monocyte activating polypeptide II (EMAPII). *Cancer Res* 59: 205–212, 1999.

908. **Xu Y, Stokes AH, Roskoski R Jr, and Vrana KE.** Dopamine, in the presence of tyrosinase, covalently modifies and inactivates tyrosine hydroxylase. *J Neurosci Res* 54: 691–697, 1998.
909. **Yaar M, Park HY, Botchkarev V, Stewart K, Panova I, and Gilchrist BA.** Bone morphogenetic protein modulates melanocyte proliferation and melanogenesis. *J Invest Derm* 119: 337, 2002.
910. **Yada Y, Higuchi K, and Imokawa G.** Effects of endothelins on signal transduction and proliferation in human melanocytes. *J Biol Chem* 266: 18352–18357, 1991.
911. **Yajima I, Sato S, Kimura T, Yasumoto K, Shibahara S, Goding CR, and Yamamoto H.** An L1 element intronic insertion in the black-eyed white (*Mitf^{mi-bw}*) gene: the loss of a single Mitf isoform responsible for the pigmentary defect and inner ear deafness. *Hum Mol Genet* 8: 1431–1441, 1999.
912. **Yalcin B, Sahin S, Bukulmez G, Karaduman A, Atakan N, Akan T, and Kolemen F.** Experience with calcipotriol as adjunctive treatment for vitiligo in patients who do not respond to PUVA alone: a preliminary study. *J Am Acad Dermatol* 44: 634–637, 2001.
913. **Yamamoto K, Tojo A, Aoki N, and Shibuya M.** Characterization of the promoter region of the human *c-kit* proto-oncogene. *Jpn J Cancer Res* 84: 1136–1144, 1993.
914. **Yamashita M, Fukui H, Sugama K, Horio Y, Ito S, Mizuguchi H, and Wada H.** Expression cloning of a cDNA encoding the bovine histamine H1 receptor. *Proc Natl Acad Sci USA* 88: 11515–11519, 1991.
915. **Yanagisawa M, Kurihara H, Kimura S, Tomobe Y, Kobayashi M, Mitsui Y, Yazaki Y, Goto K, and Masaki T.** A novel potent vasoconstrictor peptide produced by vascular endothelial cells. *Nature* 332: 411–415, 1988.
916. **Yang YK, Dickinson CJ, Zeng Q, Li JY, Thompson DA, and Gantz I.** Contribution of melanocortin receptor exoloops to Ag-outi-related protein binding. *J Biol Chem* 274: 14100–14106, 1999.
917. **Yarden Y, Kuang WJ, Yang-Feng T, Coussens L, Munemitsu S, Dull TJ, Chen E, Schlessinger J, Francke U, and Ullrich A.** Human proto-oncogene *c-kit*: a new cell surface receptor tyrosine kinase for an unidentified ligand. *EMBO J* 6: 3341–3351, 1987.
918. **Yasumoto K, Takeda K, Saito H, Watanabe K, Takahashi K, and Shibahara S.** Microphthalmia-associated transcription factor interacts with LEF-1, a mediator of Wnt signaling. *EMBO J* 21: 2703–2714, 2002.
919. **Yohn JJ, Critelli M, Lyons MB, and Norris DA.** Modulation of melanocyte intercellular adhesion molecule-1 by immune cytokines. *J Invest Dermatol* 95: 233–237, 1990.
920. **Yokoyama K, Suzuki H, Yasumoto K, Tomita Y, and Shibahara S.** Molecular cloning and functional analysis of a cDNA coding for human DOPachrome tautomerase/tyrosinase-related protein-2. *Biochim Biophys Acta* 1217: 317–321, 1994.
921. **Yokoyama K, Yasumoto K, Suzuki H, and Shibahara S.** Cloning of the human DOPachrome tautomerase/tyrosinase-related protein 2 gene and identification of two regulatory regions required for its pigment cell-specific expression. *J Biol Chem* 269: 27080–27087, 1994.
922. **Yoshida H, Kunisada T, Kusakabe M, Nishikawa S, and Nishikawa SI.** Distinct stages of melanocyte differentiation revealed by analysis of nonuniform pigmentation patterns. *Development* 122: 1207–1214, 1996.
923. **Yoshida M, Takahashi Y, and Inoue S.** Histamine induces melanogenesis and morphologic changes by protein kinase A activation via H2 receptors in human normal melanocytes. *J Invest Dermatol* 114: 334–342, 2000.
924. **Yoshimura K, Tsukamoto K, Okazaki M, Virador VM, Lei TC, Suzuki Y, Uchida G, Kitano Y, and Harii K.** Effects of all-trans retinoic acid on melanogenesis in pigmented skin equivalents and monolayer culture of melanocytes. *J Dermatol Sci* 27 Suppl 1: S68–S75, 2001.
925. **Yu HS, Chang KL, Yu CL, Li HF, Wu MT, and Wu CS.** Alterations in IL-6, IL-8, GM-CSF, TNF-alpha, and IFN-gamma release by peripheral mononuclear cells in patients with active vitiligo. *J Invest Dermatol* 108: 527–529, 1997.
926. **Yu HS and Reiter RJ.** *Melatonin Biosynthesis, Physiological Effects, and Clinical Implications.* Boca Raton, FL: CRC, 1993.
927. **Yuan Y, Granger HJ, Zawieja DC, DeFily DV, and Chilian WM.** Histamine increases venular permeability via a phospholipase C-NO synthase-guanylate cyclase cascade. *Am J Physiol Heart Circ Physiol* 264: H1734–H1739, 1993.
928. **Zachariae CO, Thestrup-Pedersen K, and Matsushima K.** Expression and secretion of leukocyte chemotactic cytokines by normal human melanocytes and melanoma cells. *J Invest Dermatol* 97: 593–599, 1991.
929. **Zagon IS, Wu Y, and McLaughlin PJ.** The opioid growth factor, [Met⁵]-enkephalin, and the zeta opioid receptor are present in human and mouse skin and tonically act to inhibit DNA synthesis in the epidermis. *J Invest Dermatol* 106: 490–497, 1996.
930. **Zecca L, Tampellini D, Gerlach M, Riederer P, Fariello RG, and Sulzer D.** Substantia nigra neuromelanin: structure, synthesis, and molecular behaviour. *Mol Pathol* 54: 414–418, 2001.
931. **Zhu Y, Michalovich D, Wu H, Tan KB, Dytko GM, Mannan IJ, Boyce R, Alston J, Tierney LA, Li X, Herrity NC, Vawter L, Sarau HM, Ames RS, Davenport CM, Hieble JP, Wilson S, Bergsma DJ, and Fitzgerald LR.** Cloning, expression, and pharmacological characterization of a novel human histamine receptor. *Mol Pharmacol* 59: 434–441, 2001.